

Manually Driven Positioning Slides & Stages



ENGINEERING YOUR SUCCESS.

Table of Contents

Introduction

2-3	Parker Partners in Automation & Support
4-5	Selectable Levels of Integration™
6-7	Parker Products and Technologies
8-12	Manual Products and Technologies

Ball Bearing Slides

13-15	Overview
16-20	1.25" Wide or Less (3500, 3900)
21-22	1.75" Wide (4000, 4100, 4200, 4300)
23-25	2.62" Wide (4500, 4600, 4700, 4800)
26-27	5" Wide (4400)
28	6" Wide (4900)

Crossed Roller Slides

35-38	Overview
39	1.496" (38 mm) Wide (SW038)
40-41	1.75" Wide (CR4000, CR4100, CR4200, CR4300)
42-43	1.97" (50 mm) Wide (SE050, SP050)
44-45	2.62" Wide (CR4500, CR4600, CR4700, CR4800)
46-47	2.95" (75 mm) Wide (SE075, SP075)
48-49	3.94" (100 mm) Wide (SE100, SP100)
50	5" Wide (CR4400)
51	6" Wide (CR4900)

Ball Bearing Positioners

61-63	Overview
64-67	1.25" Wide or Less (MM-1/3, 3900)
68-73	1.75" Wide (4000, 4100, 4200, 4300)
74-79	2.62" Wide (4500, 4600, 4700, 4800)
80-83	5" Wide (4400)
84-86	6" Wide (4900)

Crossed Roller Positioners

89-91	Overview
92-96	1.75" Wide (CR4000, CR4100, CR4200, CR4300)
97	1.97" (50 mm) Wide (SC050, SK050)
98-101	2.62" Wide (CR4500, CR4600, CR4700, CR4800)
102	2.95" (75 mm) Wide (SC075, SK075)
103	3.94" (100 mm) Wide (SC100, SK100)
104-107	5" Wide (CR4400)
108-110	6" Wide (CR4900)

Rotary Positioners

115-116	Overview
117	1.88 – 2.62" Diameter (2500)
118	2.38" Diameter (4575)
119	2.75 – 4.75" Diameter (10000, 20000)
120-121	5 – 12" Diameter (30000)

Accessories

123	Overview
124-127	Z-Axis Brackets
128-129	Drive Mechanisms
130-132	Optical Mounts

Engineering Reference

133-135	
---------	--

Part Number Index

136-142	
---------	--

To find a specific model, refer to the part number index on pages 136-142.

Welcome!

For over forty years, Parker Daedal has been the leader in supplying manual positioners to industries and laboratories around the world. These positioners are utilized for applications that include metrology, laser beam directing, fiber optics alignment, assembly fixturing, tooling, microscope specimen positioning, camera focusing, and many others — even experiments in outer space.

- Precision quality
- Budget friendly
- Largest selection
- Easy multi-axis configuration
- No maintenance
- Vacuum preparation and custom options

Parker has thousands of ball slides, crossed roller slides and linear and rotary manual positioning stages. All Parker Daedal slides and stages are precision grade products, offering low friction, accurate, and smooth linear motion.

Parker free-travel linear slides and precision point-to-point positioners are available in sizes ranging from less than half of an inch wide to 6 inches wide, travels from 1 to 30+ inches, and payload capacities to hundreds of pounds. They are available as single axis units or two and three axis systems — all offered by model number and delivered complete, with no assembly required. Rotary stages are also available for easy configuration of linear/rotary combinations.

Parker Electromechanical & Drives Division offers one of the broadest manual positioning lines in the industry. The following pages of this product guide will help you find the best fit for every application. If you cannot find what you are looking for in these pages, please do not hesitate to call our application team at 724-861-8200. Parker has extensive machining and testing capabilities to produce a solution for your application even if it is not shown in the product guide.

Ball Bearing Slides

Crossed Roller Slides

Ball Bearing Positioners

Crossed Roller Positioners

Rotary Positioners

Accessories

Engineering Reference

Parker Hannifin Corporation

Parker Hannifin is a Fortune 250 global leader in motion and control technologies. For more than 100 years the company has engineered the success of its customers in a wide range of diversified industrial and aerospace markets. Learn more at www.parker.com or @parkerhannifin.

Total System Solutions

Parker's team of highly qualified application engineers, product development engineers, and system specialists can turn electromechanical components into an integrated system solution. Moreover, our Selectable Levels of Integration™ allows you to choose the appropriate system, subsystem, or component to meet your specific need.

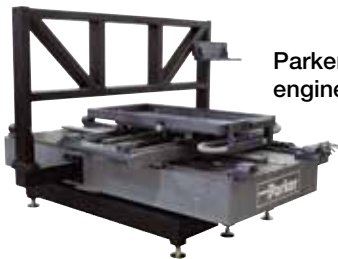

Parker offers complete engineered solutions.

First in Delivery, Distribution, and Support

In today's competitive, fast-moving economy, what good is an application that isn't ready on time? This is especially true when compressed design cycles make the quick delivery of critical components essential. With factories strategically located on five continents, Parker offers an unrivaled delivery record, getting solutions out our door and onto your floor faster than ever.

Parker also has the industry's largest global distribution network, with more than 8,600 distributors worldwide. Each of these locations maintains ample product inventory to keep your downtime to a minimum. And many distributors have in-house design capabilities to support your system and subsystem requirements.



Parker world headquarters in Cleveland, OH.



Training

Parker's best-in-class technology training includes hands-on classes, web-based instruction, and comprehensive texts for employees, distributors, and customers. Parker

also provides computer-based training, PowerPoint presentations, exams, CAD and simulation software, and trainer stands. Get the in-person training schedule at parkermotion.com/support_training.html.

parker.com/emn

Our award-winning website is your single source for

- Product information
- Downloadable catalogs
- Motion-sizing software
- 3D CAD files
- Training materials
- Product-configuration software
- RFQ capabilities
- Videos and application stories
- Selection, Sizing Tools



24/7 Emergency Breakdown Support

The Parker product information center is available any time of the day or night at 1-800-C-Parker. Our operators will connect you with a live, on-call representative who will identify replacement parts or services for all motion technologies.

Extensive Automation Solutions



HMI

Parker offers HMI solutions for every application, from simple push-button replacement to sophisticated networking, multimedia, and data logging requirements.

www.parker.com/hmi



Controllers

Parker automation controllers have advanced features built-in, such as kinematics transformation for the control of robots and other non-linear functions.

www.parker.com/emn/pac



Drives

Parker servo, stepper, and variable frequency drives deliver maximum power output and performance with optional integrated control capability and multiple communication protocols.

www.parker.com/drives



Motors

Parker rotary motors provide maximum torque density, cog-free rotary motion for the best low-speed smoothness and the greatest winding uniformity and accuracy in the industry.

www.parker.com/motors



Gearheads

With expert machining and high precision designs, Parker gearheads have precision options with less than three arc-minutes of backlash. Other options include NEMA sizes, right angle, dual drive, and more.

www.parker.com/gearheads



Positioners

Parker offers best-in-class positioner designs with screw, belt, or linear motor-drive technologies. Our award-winning designs lead the way with unmatched flexibility and precision capabilities.

www.parker.com/linear



Electric Actuators

Screw, belt-driven, and linear motor actuators for the complete range of industrial applications, offering precise motion and flexibility.

www.parker.com/linear



Cylinders

Parker has one of the most complete electric cylinder product lines available, with high speed linear motor versions, high-force ball screw cylinders, extreme-force roller screw cylinders, and more.

www.parker.com/cylinder



Air Control Valves

Valve technology that meets the most demanding requirements in any industrial application.

www.parker.com/pneu/valve



Air Preparation

Parker, the industry leader in air preparation, offers a complete line of products to ensure clean, dry, oil-free air.

www.parker.com/pneu/airprep



Pneumatic Actuators

Aluminum and steel pneumatic cylinders, guided cylinders, rodless cylinders, and short stroke thrusters from the industry leader.

www.parker.com/pneu/cylinders



Structural Automation

Parker has over 150 metric and inch profiles, integral motion components, and accessories for unlimited configurations, in pre-machined kits or complete assemblies.

www.parker.com/ips



Today's positioning applications demand performance in quality, throughput, productivity and precision. Miniaturization of semiconductor, electronics and life science applications have created the need to partner with companies that have the experience and products to meet stringent specifications for smaller, more precise motion positioning solutions.

Parker's dedicated electromechanical business leads the way for manual positioning to efficiently assist in many industries including:

- Semiconductor
- Electronics
- Packaging
- Life science
- Medical equipment
- Laboratory research
- Optical inspection & adjustments
- Laser cutting & marking
- Automotive manufacturing and assembly
- Printing
- Material handling
- Military applications

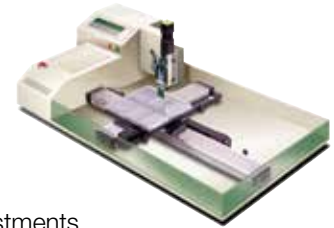

Since 1969 Parker has been producing these precision slides in Pennsylvania. These slides are precision grade products, offering low friction, accurate, and smooth linear motion. The stages offer digital micrometers, imperial and metric micrometers, knobs, cranks, hand wheels, and fine lead screws for drives. Each of these precision machined assemblies is offered with either cross roller bearings for high load capacities or caged ball bearings for smooth motion.

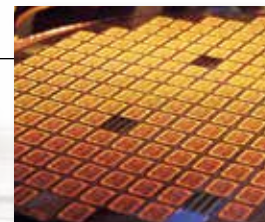

Customization and Services

Parker has a Custom Systems Group staffed by experienced engineers and technicians who utilize systematic processes for handling component modifications or complete one-of-a-kind systems.

The System is the Product

Many of the components shown in this catalog are modified specifically to customer request and need. Parker system customers can receive many optional services such as:

- 3-D custom assembly drawings
- Electronics integration
- Finite element analysis
- Life load testing
- Integration with the breadth of Parker product



Our advanced manufacturing and assembly process allows us to build quality and consistency into every element of your motion system. Each mechanical system is fully assembled prior to shipment and each component is properly handled to protect finish and appearance. Performance and specifications are verified with state-of-the-art testing, including:

Cleanroom Testing

Parker is equipped with particulate testing to certify materials for cleanroom ratings.

EMI Testing

Parker has an EMI test chamber, which allows us to test equipment to verify levels of electromagnetic interference.



Precision Metrology Lab

When precision is critical to your process, you need validated, proven performance data. Parker certifies all precision-grade positioners using state-of-the-art laser interferometers, and provides reports to validate accuracy and bidirectional repeatability.

24/7 Emergency Breakdown Referrals

The Parker product information center at 800-C-PARKER offers live operators 24/7 to help identify replacement parts or services.

Parker Automation Technology Centers

Parker Automation Technology Centers are a network of premier product and service providers who can serve you locally for your automation needs. Each Automation Technology Center is certified to have completed significant product training and has the ability to provide subsystem solutions with local support.

Industry's Best Lead Times

#1 rated, industry-leading, on-time delivery to customer-requested ship dates. For more than 3 years and over 100 thousand manual products, we have delivered 100% on-time to our agreed upon customer request delivery date for the Parker manual slide and stage product lines.

www.parker.com/emdusa

The Parker Electromechanical & Drives site offers the most extensive online support tools in the industry, including:

- Complete online catalog
- FAQ database with more than 500 answers to common questions
- Interactive product sizing and selection tool
- Comprehensive CAD drawings and 3-D models for electronic and mechanical products
- User guides and detailed product specifications
- Latest software and firmware revisions
- Application case studies and videos
- Custom solutions photo library
- Innovative technology white papers

One-on-One with a Motion Control Expert Toll-Free Applications Engineering Assistance

When you have urgent questions, expert answers are only a phone call away. Our team of experienced engineers is ready to take your call. These engineers have practical field experience and can provide you with application and product assistance throughout the stages of your project and for the life of the product. For presale support, including sizing and selecting systems, call 800-245-6903 (724-861-8200 outside the US). For post-sale support with technical questions on programming and troubleshooting, call 800-358-9070 (707-584-7558 outside the US). Our staffing and support tools allow us to resolve most issues and get your project rolling in less than one hour.

Whether using one component or an entire system, Parker has the right solution. In addition to the Parker manual positioning slides and stages, Parker Electromechanical Automation Division offers a vast array of motion and control products including:

To download catalogs or for complete on-line information, go to www.parker.com/emdusa



HMI (Human-Machine Interface)

Parker offers HMI solutions for any application from simple pushbutton replacement to sophisticated networking, multimedia and data logging requirements. Parker pre-loads Interact or InteractX HMI software on PowerStation industrial computers to provide a ready-to-go HMI solution. This bundled approach reduces development and integration time for your HMI project.



Motion Controllers

Parker motion controllers are powerful designs that have the processing power to coordinate multiple axes of motion. Parker controllers have advanced features built in, such as kinematics transformation for the control of robots and other non-linear functions. Each Parker controller comes with free libraries for Visual Basic® and Visual C++®.





Drives

Parker drives are digital designs that deliver a maximum amount of power output and performance in minimal package size. These drives have industry-leading power density and smart digital designs with features to ease integration and start-up.



Motors

Using advanced technologies, Parker rotary motors provide maximum performance and value. Our exposed-lamination designs provide maximum torque per package size, and the motor designs provide cog-free rotary motion for the best low-speed smoothness. Patented linear motor designs provide the greatest winding uniformity and accuracy in the industry, and range from the smallest linear motor on the market to the largest force capacity.



Gearheads

High-precision designs, Parker gearheads have less than three arc-min of backlash. They have an industry-leading two-year warranty.



Positioning Tables

Parker multi-axis positioning tables integrate linear motors or ground ballscrews. The designs combine the low cost of extruded aluminum with machined bases allowing "out of the box" submicron precision. Our positioning tables are modular designs that easily accommodate flexible configurations such as XY and XYZ.



Actuators

Parker actuators are modular single-axis actuators that can be easily configured in multi-axis systems. These actuators are screw- or belt-driven and give the designer a great deal of flexibility to apply the right actuator technology to meet the application needs for accuracy, speed and distance.



End Effectors

With the broadest range of automation products in the industry, Parker provides pneumatic grippers, rotary actuators and vacuum components for a wide range of applications.



Structural Framing

Parker Industrial Profile Systems provide full engineering, fabrication and assembly for any structural design. We provide the profiles, fasteners and accessories to complete any system. The only limitation is your imagination.



I/O

The Parker I/O system is a modular and flexible remote I/O system designed to work with today's common fieldbuses. The modular design of the Parker I/O allows the user to choose the number and type of I/O points that best suit each application.



Systems

Parker's systems combine the breadth of our motion control solutions into XY systems, Cartesian robots, gantry systems, or completely custom configurations.

Parker's Selectable Levels of Integration™ is a philosophy of product development and management that allows the machine builder to select an appropriate system, subsystem, or component to meet a specific need.

Parker has solutions for machine builders of all types, from those who want a complete integrated system to those who want to build their own system from "best of breed" components.

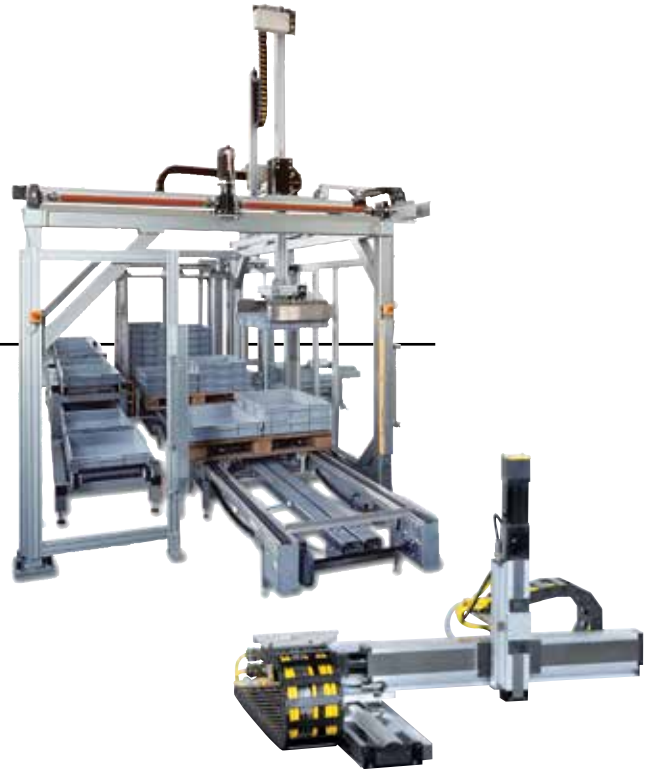

Systems

Machine builders and OEMs often choose to integrate more than a manual slide or stage into their machine. They have confidence in knowing that our knowledge, experience, and support will ensure that their goals are met. Minimal design engineering ensures component compatibility from a single source.

Subsystems and Bundled Products

For a cost-effective and efficient solution, Parker offers bundled or kitted systems. We offer multi-axis solutions to deliver a configured subsystem ready for installation. If electromechanical motion is included, Parker configuration and setup software accommodates the rest of the product line, making start-up a snap. Combining this with our custom product modification capabilities gives the machine builder an economical custom-fit solution, with reduced engineering effort, straightforward integration, and modular compatibility.



Component Products

Parker has thousands of ball slides, cross roller slides and linear and rotary manual positioning stages. If you have the capability and experience to develop your own systems, our innovative, easy-to-use products will help you get the job done. Parker provides short lead times, large selection, and proven reliability. All Parker slides and stages are precision machined and easy to install.

Please review the next several pages for a technical overview of our manual product line.

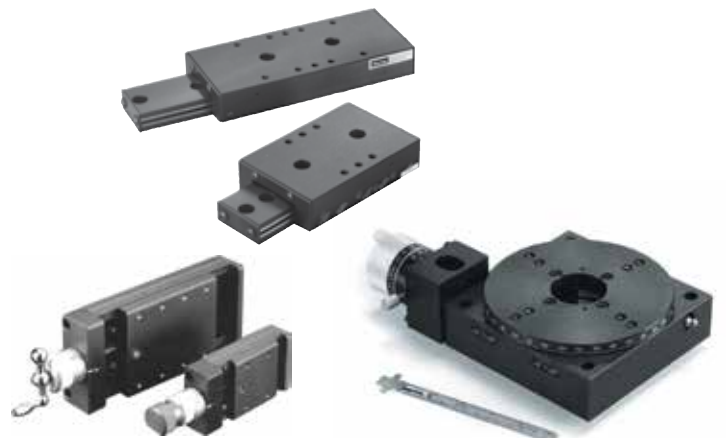

Visit our Website

Complete up-to-date technical assistance can be found on the web at www.parkermotion.com. This includes all the latest information on current products, new product introductions, local assistance and support, plus a comprehensive "Engineering Reference Library."

- Complete product catalogs
- Product selection wizards
- Performance charts and graphs
- Engineering data and calculations
- CAD drawings
- Local service and support directory
- On-line purchasing
- Application stories and videos

Using our Catalog

This catalog is divided into several sections based on primary distinguishing characteristics such as drive technology, degree of precision, travel range, and load capacity. A brief overview and selection is provided on the following pages.

If you don't find exactly what you are looking for, please contact us for information on other suitable Parker products.

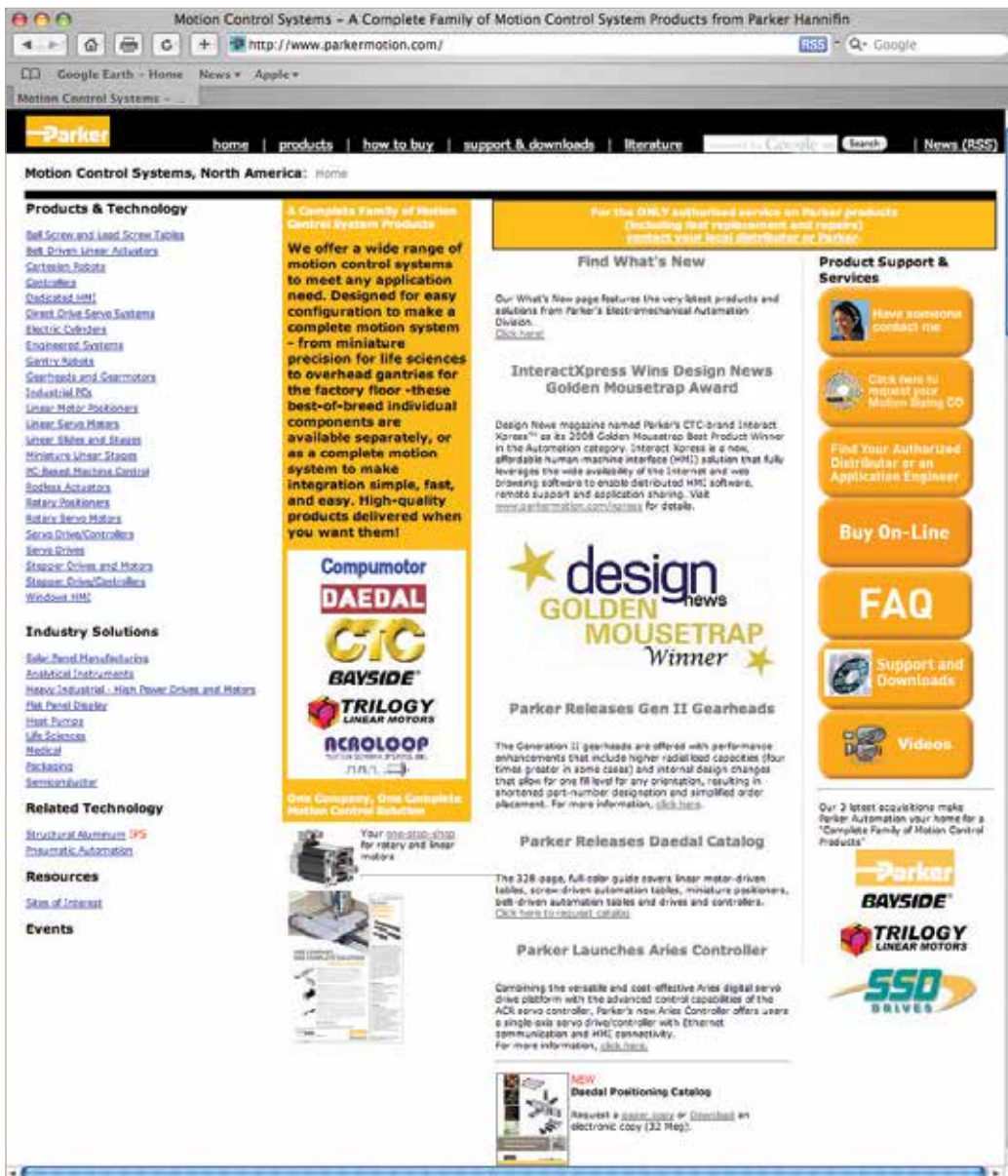



Ball Bearing Slides
Pages 13-34

Parker ball slides are mechanically simple linear bearings, which are designed and assembled to provide exceptional smoothness and linear straight line accuracy. This is achieved by the ball and rod linear bearing design.

The ball and rod bearings on Parker ball slides consist of two rows of hardened steel balls, each preloaded between

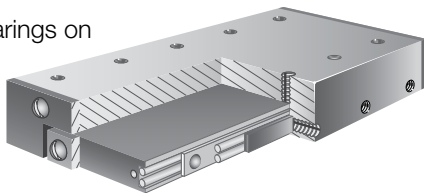

four hardened ground steel rods. This design provides ultra-smooth, extremely low-friction motion by reducing the contact area between the balls and the ways. Additionally this design provides extremely good straight line and flatness accuracy. All Parker ball bearing slides incorporate 440C hardened stainless steel ball and rods to ensure corrosion resistance and long life.

Both the top and base aluminum mounting surfaces are precision machined to ensure flatness. Most models are available in both Imperial and metric mounting configurations.

Ball slides are functionally much more reliable than simple dovetail slides, since there is no direct sliding contact of the top and bottom members. Ball slides eliminate the rapid wear problems, regular lubrication requirements, and “stiction” (skipping and jumping caused by the increased force needed to initiate movement) characteristic of dovetail slides.

Functional Comparison

	Smoothness	Friction	Straightness/ Flatness Accuracy	Load Capacity
Ball Bearing Slide	Exceptional	Extremely Low	Very Good	Moderate
Crossed Roller Slide	Very Good	Very Low	Very Good	High

Crossed Roller Slides
Pages 35-60

Crossed roller slides are very similar to ball slides, except the ball and rod linear bearing is replaced with a crossed roller slide bearing system composed of two rows of rollers. Each roller is alternately crossed at 90° with the next and captured in “V” grooves, located on the base and top.

Since rollers provide a larger (line) contact surface than ball bearings, a crossed roller slide has higher load carrying capability than a ball slide of comparable size. These changes also significantly increase the stiffness by increasing the contact area of each bearing.

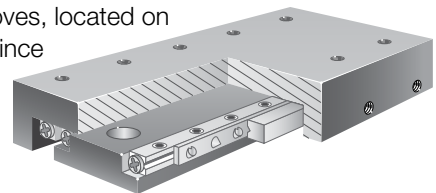

Crossed roller slides are preloaded during the manufacturing process to eliminate any side play and to provide a uniform coefficient of friction. Like the ball slide, the crossed roller slide is not suggested for use in shock load applications.

The crossed roller slide top and base are designed the same as ball bearing slide. Crossed roller slides are constructed of corrosion-resistant black anodized aluminum and high carbon steel. These building materials provide optimized stiffness and thermal stability without excessive mass. Members are precision machined to assure flatness and parallelism for both top and bottom mounting surfaces. Crossed roller slides are available in imperial and metric mounting configurations depending on model selection.

Series	Width in (mm)	Travel		Ball Bearing Slides				Crossed Roller Slides				
		in	(mm)	Normal Load lbs (kg)	Mounting Imperial Metric		Page	Normal Load lbs (kg)	Mounting Imperial Metric		Page	
3500 3900	≤1.25 (≤31,8)	0.5	(12,7)	4.9 (2,2)	•		16					
				5.0 (2,3)	•		17					
				17.0 (7,6)	•		18					
				6.0 (2,7)	•	•	20					
		0.75	(19,1)	14.6 (6,6)	•			19				
		1.00	(25,4)	10.3 (4,6)	•			16-17				
		29.0 (13,1)	•		18							
1.50	(38,1)	24.3 (11,0)	•			19						
2.00	(50,8)	14.0 (6,3)	•			16-17						
36.0 (16,3)	•		18-19									
3.00	(76,2)	23.0 (10,3)	•			16-17						
43.0 (19,5)	•		19									
4.00	(101,6)	56.0 (25,4)	•			19						
SW038	1.496 (38,0)	0.98	(25)					175	(97)	•	39	
		1.97	(50)					263	(119)	•	39	
		2.95	(75)					351	(159)	•	39	
		3.94	(100)					439	(199)	•	39	
		4.92	(125)					528	(239)	•	39	
		5.91	(150)					614	(278)	•	39	
		7.87	(200)					789	(358)	•	39	
4000 4100 4200 4300	1.75 (44,5)	1.00	(25,4)	25 (11)	•	•	21	81	(36)	•	40	
28 (13)		•	•	22	81	(36)	•	41				
2.00		(50,8)	40 (18)	•	•	22	121	(54)	•	41		
3.00		(76,2)	55 (25)	•	•	22	131	(59)	•	41		
SE050 SP050	1.97 (50,0)	0.98	(25)					175	(80)	•	42-43	
		1.97	(50)					263	(119)	•	42-43	
		2.95	(75)					351	(159)	•	42-43	
		3.94	(100)					439	(199)	•	42	
		4.92	(125)					526	(239)	•	42	
		5.91	(150)					614	(278)	•	42	
		6.89	(200)					789	(358)	•	42	
4500 4600 4700 4800	2.62 (66,5)	1.0	(25,4)	62 (28)	•	•	23	111	(50)	•	44	
		2.0	(50,8)	88 (40)	•	•	24	151	(69)	•	45	
		3.0	(76,2)	106 (48)	•	•	24	201	(91)	•	45	
		4.0	(101,6)	123 (56)	•	•	24	252	(114)	•	45	
		6.0	(152,4)	154 (70)	•		25					
		9.0	(228,6)	192 (87)	•		25					
		12.0	(304,8)	205 (93)	•		25					
		15.0	(381,0)	243 (110)	•		25					
		18.0	(457,2)	281 (128)	•		25					
		21.0	(533,4)	332 (151)	•		25					
		24.0	(609,6)	371 (168)	•		25					
		27.0	(685,8)	410 (186)	•		25					
30.0	(762,0)	448 (203)	•		25							
SE075 SP075	2.95 (75,0)	1.97	(50)					203	(119)	•	46	
		351	(159)	•	47							
		2.95	(75)					351	(159)	•	46	
		439	(199)	•	47							
		3.94	(100)					439	(199)	•	46	
		4.92	(125)					526	(239)	•	46	
		5.91	(150)					614	(278)	•	46	
6.89	(200)					789	(358)	•	46			
SE100 SP100	3.94 (100,0)	0.98	(25)					439	(199)	•	49	
		1.97	(50)					520	(239)	•	49	
		2.95	(75)					795	(361)	•	48	
		614	(278)	•	49							
		3.94	(100)					702	(318)	•	49	
		4.92	(125)					1236	(561)	•	48	
		7.87	(200)					2031	(921)	•	48	
11.81	(300)					2738	(1242)	•	48			
4400 4900	5.0 (127,0)	2.0	(50,8)	77 (35)	•	•	27					
3.0		(75,0)	106 (48)	•	•	26	201	(90)	•	50		
4900	6.0 (152,4)	4.0	101,6	100 (45)	•	•	28	423	(191)	•	51	
		6.0	152,4	154 (70)	•	•	28	719	(350)	•	51	
		8.0	203,2	205 (93)	•	•	28	1057	(475)	•	51	
		10.0	254,0	243 (110)	•	•	28	1395	(633)	•	51	
		12.0	304,8	294 (133)	•	•	28	1733	(786)	•	51	



Ball Bearing Positioners

Pages 61-88

Parker ball bearing positioners combine a ball slide with a drive mechanism. The ball slide is spring loaded against the drive mechanism to provide a constant preload between the drive and the slide.

These positioners are available with a number of different drive mechanisms including fine adjustment screw, differential screw, imperial and metric micrometer heads, and digital micrometer heads.

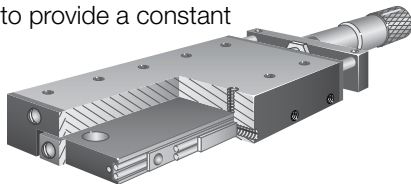

The ball and rod bearings on the ball bearing positioners consist of two rows of hardened steel balls, each preloaded between four hardened ground steel rods. This design provides ultra-smooth, extremely low-friction motion by reducing the contact area between the balls and the ways. Additionally, this design provides extremely good straight line and flatness accuracy. All Parker ball bearing slide positioners incorporate 440C hardened stainless steel ball and rods to ensure corrosion resistance and long life.

Both the top and base aluminum mounting surfaces are precision machined to ensure flatness. Most models are available in both imperial and metric mounting configurations.

Crossed Roller Positioners

Pages 89-114

Parker crossed roller positioners combine a crossed roller slide with a drive mechanism. The crossed roller slide is spring loaded against the drive mechanism to provide a constant preload between the drive and the slide.

These positioners are available with a number of different drive mechanisms including fine adjustment screw, differential screw, imperial and metric micrometer heads, and digital micrometer heads.

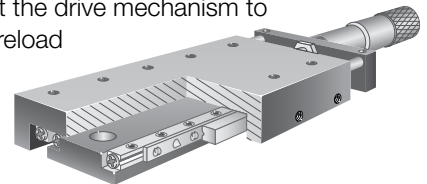

The crossed roller bearing system is composed of two rows of rollers. Each roller is alternately crossed at 90° with the next and captured in “V” grooves, located on the base and top. Since rollers provide a larger (line) contact surface than ball bearings, a crossed roller positioner has higher load carrying capability than a ball bearing positioner of comparable size. These changes also significantly increase the stiffness by increasing the contact area of each bearing. Crossed roller positioners are preloaded to eliminate any side play and to provide a uniform coefficient of friction.

Crossed roller positioners are constructed of corrosion-resistant black anodized aluminum and high carbon steel. Members are precision machined to assure flatness and parallelism for both top and bottom mounting surfaces. Crossed roller positioners are available in imperial and metric mounting configurations depending on model selection.

Functional Comparison

	Smoothness	Friction	Straightness/ Flatness Accuracy	Load Capacity
Ball Bearing Positioner	Exceptional	Extremely Low	Very Good	Moderate
Crossed Roller Positioner	Very Good	Very Low	Very Good	High



Ball Bearing Positioners

Series	Width in (mm)	Travel		Normal Load		Drive Orientation		Special Configurations			Mounting		Page	
		in	(mm)	lbs	(kg)	Center	Side	Digital Micrometer	Multiaxis Capability	Leadscrew Drive	Imperial	Metric		
MM-1	≤1.25 (≤31,8)	0.125	(3,2)	0.5	(0,25)	•			•		•		64-65	
MM-3 3900		0.50	(12,7)	0.75 6	(0,34) (2,7)	•	•		•	•	•	•		64-65 66-67
4000	1.75 (44,5)	1.00	(25,4)	25	(11)	•	•	•	•		•	•	68-69,72	
4100				29	(13)	•		•	•	•	•	•	•	70-71, 73
4200				42	(18)	•		•	•	•	•	•	•	70-71, 73
4300				55	(25)	•		•	•	•	•	•	•	70-71, 73
4500	2.62 (66,5)	1.00	(25,4)	62	(28)	•	•	•	•		•	•	74-75, 78	
4600				88	(40)	•		•	•	•	•	•	•	76-77, 79
4700				166	(48)	•		•	•	•	•	•	•	76-77, 79
4800				123	(56)	•		•	•	•	•	•	•	76-77, 79
4400	5.0 (127,0)	1.0	(25,4)	106	(48)	•	•	•	•		•	•	80-83	
		2.0	(50,8)	106	(48)	•	•	•	•		•	•	80-83	
4900	6.0 (152,4)	1.0	(25,4)	102	(46)	•			•		•	•	84-85	
		2.0	(50,8)	102	(46)	•		•	•		•	•	84-85	
		4.0	(100,0)	102	(46)	•		•	•	•		•	86	
		6.0	(150,0)	154	(70)	•		•	•	•	•	•	86	
		8.0	(200,0)	205	(93)	•		•	•	•	•	•	86	
		10.0	(250,0)	243	(110)	•		•	•	•	•	•	86	
		12.0	(300,0)	294	(133)	•		•	•	•	•	86		

Crossed Roller Positioners

Series	Width in (mm)	Travel		Normal Load		Drive Orientation		Special Configurations			Mounting		Page	
		in	(mm)	lbs	(kg)	Center	Side	Digital Micrometer	Multiaxis Capability	Leadscrew Drive	Imperial	Metric		
CR4000	1.75 (44,5)	1.00	(25,4)	81	(36)	•	•	•	•		•		92-94	
CR4100				81	(36)	•		•	•	•	•	•	•	95-96
CR4200				121	(54)	•		•	•	•	•	•	•	95-96
CR4300				131	(59)	•		•	•	•	•	•	•	95-96
SC050	1.97 (50)	0.98	(25)	175	(80)	•			•	•			97	
SK050		1.97	(50)	263	(119)	•			•	•				
		2.95	(75)	351	(159)	•			•	•				
CR4500	2.62 (66,5)	1.00	(25,4)	111	(50)	•	•	•	•		•		98-99, 101	
CR4600				151	(69)	•		•	•	•	•	•	•	100-101
CR4700				201	(91)	•		•	•	•	•	•	•	100-101
CR4800				252	(114)	•		•	•	•	•	•	•	100-101
SC075	2.95 (75)	0.98	(25)	351	(159)	•			•	•			102	
SK075		1.97	(50)	439	(199)	•			•	•				
		2.95	(75)	526	(239)	•			•	•				
SC100	3.94 (100)	0.98	(25)	439	(199)	•			•	•			103	
SK100		1.97	(50)	526	(239)	•			•	•				
		2.95	(75)	614	(278)	•			•	•				
		3.94	(100)	702	(318)	•			•	•				
CR4400	5.0 (127,0)	1.00	(25,4)	201	(90)	•	•	•	•		•		104-107	
		2.00	(50,8)	201	(90)	•	•	•	•		•		104-107	
CR4900	6.0 (152,4)	1.00	(25,4)	150	(68)	•			•		•		108-109	
		2.00	(50,8)	220	(100)	•		•	•		•		108-109	
		4.00	(100,0)	423	(199)	•		•	•	•		•	110	
		6.00	(150,0)	719	(318)	•		•	•	•	•		110	
		8.00	(200,0)	1057	(410)	•		•	•	•	•		110	
		10.00	(250,0)	1395	(635)	•		•	•	•	•		110	
		12.00	(300,0)	1733	(786)	•		•	•	•		110		

Rotary Positioners

Pages 115-122

Parker rotary stages are designed to produce precision rotary motion. The basic components in these stages are a base, main bearing, drive mechanism and top (load platform). The base of all the units house the main bearing and drive mechanism and is designed to be mounted to a stationary surface. The main bearings provide low friction contact between the base and top. The drive mechanisms used are either tangent arms or worm gears. The table top provides a mounting surface for mounting payloads.



Tangent Arm Drive

Tangent arm drives produce very fine resolution over a limited rotary travel range. Angular rotation is controlled by three control knobs. The release knob disengages the shaft from the drive, freeing the table to be rotated by hand to a desired location. The release knob is then tightened to re-engage the drive mechanism and transfer control to the adjustment knob which, when rotated, produces precise angular positioning of the shaft and table top. The locking knob can then be used to positively lock the table at the desired setting.

Worm Gear Drive

A precision worm gear drive mechanism consists of a worm wheel (gear) and worm drive. Controlled rotation of the worm drive shaft creates precise angular rotation of the worm wheel and table top. The worm gear and shaft are matched sets and are preloaded to remove backlash. This type of drive provides high resolution (180:1) and continuous angular positioning over a full 360° range..

Model Series	Table Diameter	Drive Mechanism	Normal Load	Mounting		Page
				Imperial	Metric	
2500 M2500	1.88 – 2.62 in 47,7 – 66,5 mm	Tangent Arm	10 lb 4,5 kg	•	•	117
4575* M4575*	2.38 in 60,5 mm	Tangent Arm	5 lbs 2,25 kg	•	•	118
10000-20000 M10000-M20000	2.75 – 4.75 in 69,8 – 120,6 mm	Worm Gear	50 lbs 22,0 kg	•	•	119
30000 M30000	5.00 – 12.00 in 127,0 – 305,0 mm	Worm Gear	25 – 200 lbs 11,5 – 90,0 kg	•	•	120-121

* Models 4575/M4575 are combination rotary and linear stages which also provide 0.50 in (12.7 mm) of linear travel.

Accessories

Pages 123-132

Z-Axis Brackets enable ball bearing and cross roller stages to be configured into a variety of three axis positioning systems.



Drive Mechanisms are available in a choice of drive mechanisms including imperial and metric micrometer heads, digital micrometers, fine adjustment screws and differential screws

Optical Mounts are available as a ready made bolt down accessory compatible with most any manual positioning slide or stage.



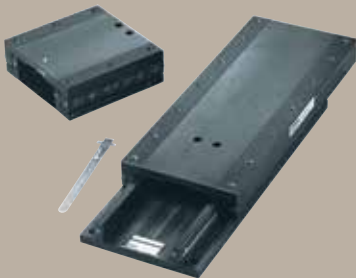
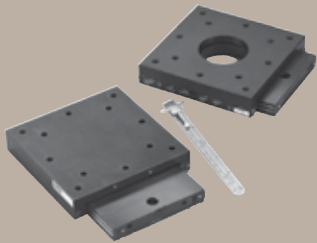
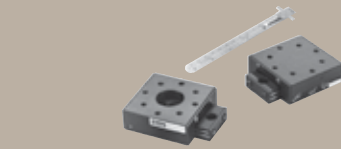

Ball Bearing Slides

Miniature and Standard

Parker miniature and standard size ball bearing slides are a popular solution for most applications requiring inexpensive yet accurate and reliable linear motion. Parker ball slides are offered in many different sizes and styles. Proper sizing and selection is based on travel, load, dimensional and mounting requirements, open aperture or solid top configurations, etc. Based on large scale production and inventory capabilities, Parker offers exclusively precision grade ball slides at prices comparable to other brands of commercial quality products.

Contents

14-15	Overview
16-20	1.25" (31,8 mm) Wide or Less
21-22	1.75" (44,5 mm) Wide
23-25	2.62" (66,5 mm) Wide
26-27	5.00" (127,0 mm) Wide
28	6.00" (152,4 mm) Wide
29-34	Performance Curves

Miniature and Standard Size Ball Bearings Slides



- Precision quality
- Budget friendly
- Largest selection
- Easy multi-axis configuration
- No maintenance
- Vacuum preparation and custom options

Ball Slide Design Principles

Parker ball slides are mechanically simple linear motion devices comprised of a stationary base member with a mobile carriage riding on top. Two rows of hardened steel balls on both sides of the base provide the smooth, accurate, low friction sliding motion between the stationary base and the top slide. Each row of bearings is contained between four hardened and precision ground steel rods. These bearing assemblies are factory preloaded to eliminate wobble and unwanted play in the system.

Ball slides are functionally much more reliable than simple dovetail slides, since there is no direct sliding contact of the top and bottom members. Ball slides eliminate the rapid wear problems, regular lubrication requirements, and “stiction” (skipping and jumping caused by the increased force needed to initiate movement) characteristic of dovetail slides. Parker also offers a high load capacity, long life crossed roller slides for applications requiring maximum load and life performance.

Standard Features

All models offer high quality construction features as standard:

- Straight line accuracy of 0.00008 inches per inch of travel (0.00025 inches per inch of travel for miniatures)
- Precision machined mounting surfaces to assure flatness and parallelism
- Factory preloaded to precision specifications to eliminate any side play and provide a uniform coefficient of friction
- Factory threaded mounting holes on the top for easy payload mounting
- Factory machining services for special hole configurations and custom modifications
- Locking thread inserts on preloaded screws for maintenance-free life without loss of preload
- Hardened and precision machined 440C stainless steel balls and rods

How to Order

Use the overview chart on the following page to select the appropriate ball slide. Refer to the individual specifications page for complete performance and mechanical specifications. To order ball slides, use the model number corresponding to the specific size and travel length selected. A variety of modifications to standard models are available to meet custom requirements. Contact our application engineering department with your design specifications.

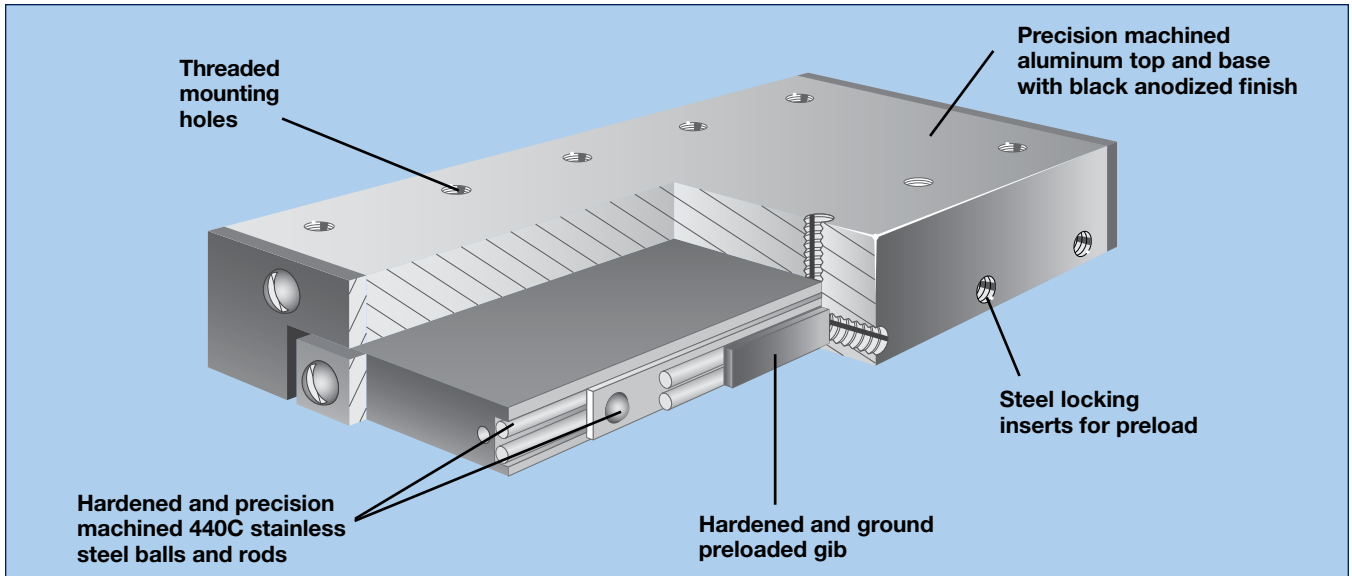

Selection

Series	Width in (mm)	Travel		Normal Load		Mounting		Page
		in	(mm)	lbs	(kg)	Imperial	Metric	
3500 3900	≤1.25 (≤31,8)	0.5	(12,7)	4.9	(2,2)	•		16
				5.0	(2,3)	•		17
				17.0	(7,6)	•		18
				6.0	(2,7)	•	•	20
		0.75	(19,1)	14.6	(6,6)	•		19
		1.00	(25,4)	10.3	(4,6)	•		16-17
		29.0	(13,1)	•		18		
		1.50	(38,1)	24.3	(11,0)	•		19
		2.00	(50,8)	14.0	(6,3)	•		16-17
		36.0	(16,3)	•		18-19		
3.00	(76,2)	23.0	(10,3)	•		16-17		
43.0	(19,5)	•		19				
4.00	(101,6)	56.0	(25,4)	•		19		
4000 4100 4200 4300	1.75 (44,5)	1.00	(25,4)	25	(13)	•	•	21
28	(13)	•	•	22				
2.00	(50,8)	40	(18)	•	•	•	22	
3.00	(76,2)	55	(25)	•	•	•	22	
1.0	(25,4)	62	(28)	•	•	•	23	
2.0	(50,8)	88	(40)	•	•	•	24	
3.0	(76,2)	106	(48)	•	•	•	24	
4.0	(101,6)	123	(56)	•	•	•	24	
6.0	(152,4)	154	(70)	•			25	
9.0	(228,6)	192	(87)	•			25	
12.0	(304,8)	205	(93)	•			25	
15.0	(381,0)	243	(110)	•			25	
18.0	(457,2)	281	(128)	•			25	
21.0	(533,4)	332	(151)	•			25	
24.0	(609,6)	391	(168)	•			25	
27.0	(685,8)	410	(186)	•			25	
30.0	(762,0)	448	(203)	•			25	
4400 4900	5.0 (127,0)	2.0	(50,8)	77	(35)	•	•	27
3.0	(75,0)	106	(48)	•		•	26	
4.0	(100,0)	100	(45)	•		•	28	
6.0	(150,0)	154	(70)	•		•	28	
8.0	(200,0)	205	(93)	•		•	28	
10.0	(250,0)	243	(110)	•		•	28	
12.0	(300,0)	294	(133)	•		•	28	

3505 Series

Specifications	
Travel:	0.5 – 3.0 in
Size:	
Width	0.59 in
Length	1.12 – 4.12 in
Height	0.32 in
Load:	
Normal	4.9 – 23.0 lbs
Moment: Yaw, Pitch, Roll	See page 29
Straight line accuracy:	0.00025 in/in of travel
Metric thread option:	M2 x 0,4 (consult factory)
Construction:	Aluminum top and base/ 440C stainless steel bearings
Mounting surface:	Precision machined
Finish:	Black anodize



Dimensions in (mm)

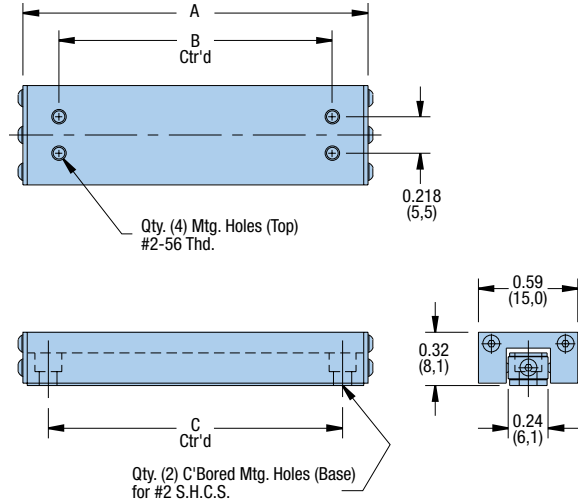

	Dimensions												
	Travel		Normal Load		Weight		A		B		C		
	Model	in	(mm)	lbs	(kg)	lbs	(kg)	in	(mm)	in	(mm)	in	(mm)
Imperial	3505-05	0.5	(12,7)	4.9	(2,2)	0.03	(0,01)	1.12	(28,4)	0.63	(16,0)	0.75	(19,1)
	3505-10	1.0	(25,4)	10.3	(4,6)	0.04	(0,02)	2.12	(53,8)	1.63	(41,4)	1.38	(35,1)
	3505-20	2.0	(50,8)	14.0	(6,3)	0.06	(0,03)	3.12	(79,2)	2.63	(66,8)	2.38	(60,5)
	3505-30	3.0	(76,2)	23.0	(10,3)	0.08	(0,04)	4.12	(104,6)	3.63	(92,2)	3.38	(85,9)



3507 Series

Specifications

Travel:	0.5 – 3.0 in
Size:	
Width	0.75 in
Length	1.12 – 4.12 in
Height	0.40 in
Load:	
Normal	5.0 – 23.0 lbs
Moment: Yaw, Pitch, Roll	See page 29
Straight line accuracy:	0.00025 in/in of travel
Metric thread option:	M2 x 0,4 (consult factory)
Construction:	Aluminum top and base/ 440C stainless steel bearings
Mounting surface:	Precision machined
Finish:	Black anodize



Dimensions in (mm)

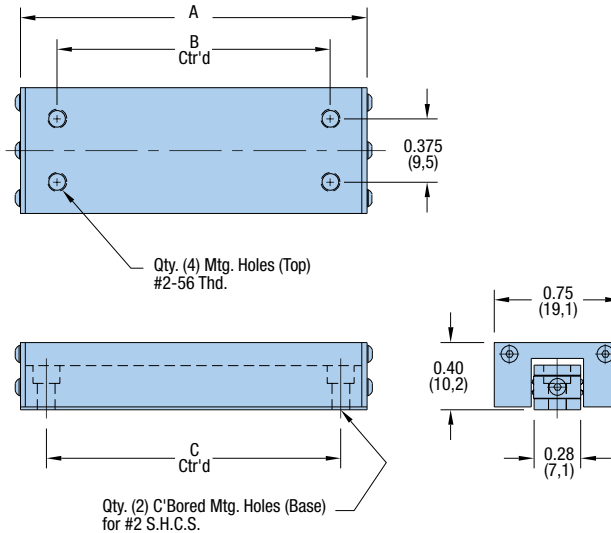

	Travel		Normal Load		Weight		Dimensions						
	Model	in	(mm)	lbs	(kg)	lbs	(kg)	A	B	C			
Imperial	3507-05	0.5	(12,7)	5.0	(2,3)	0.04	(0,02)	1.12	(28,4)	0.63	(16,0)	0.75	(19,1)
	3507-10	1.0	(25,4)	10.3	(4,6)	0.06	(0,03)	2.12	(53,8)	1.63	(41,4)	1.38	(35,1)
	3507-20	2.0	(50,8)	14.0	(6,3)	0.08	(0,04)	3.12	(79,2)	2.63	(66,8)	2.38	(60,5)
	3507-30	3.0	(76,2)	23.0	(10,3)	0.10	(0,05)	4.12	(104,6)	3.63	(92,2)	3.38	(85,9)

3510 Series

Specifications	
Travel:	0.5 – 2.0 in
Size:	
Width	1.00 in
Length	1.68 – 3.68 in
Height	0.50 in
Load:	
Normal	17 – 36 lbs
Moment: Yaw, Pitch, Roll	See page 30
Straight line accuracy:	0.00025 in/in of travel
Metric thread option:	M2 x 0,4 (consult factory)
Construction:	Aluminum top and base/ 440C stainless steel bearings
Mounting surface:	Precision machined
Finish:	Black anodize

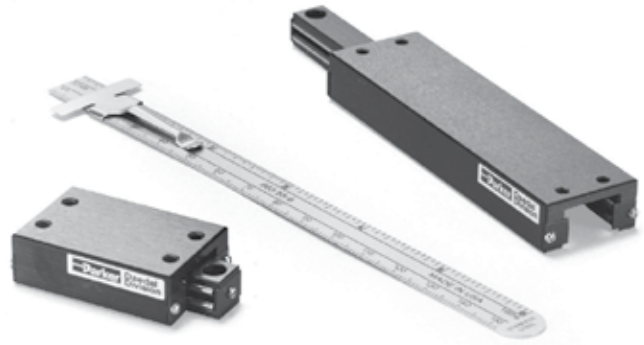

Dimensions in (mm)

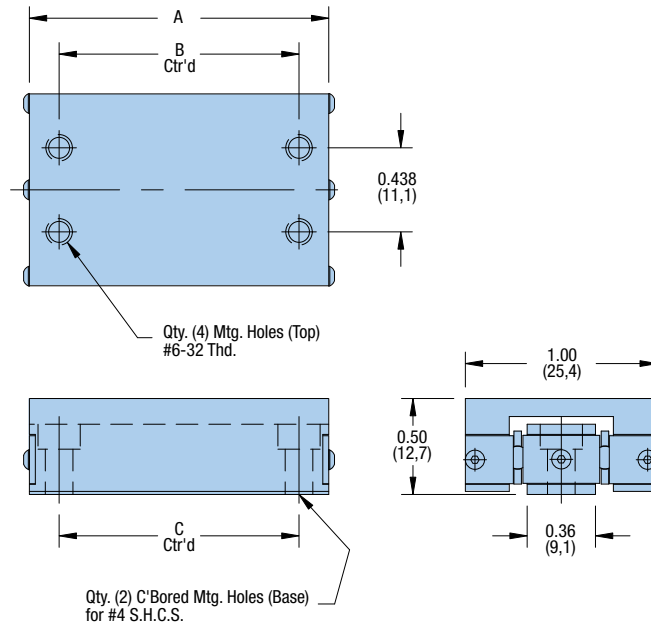

	Model	Travel		Normal Load		Weight		Dimensions					
		in	(mm)	lbs	(kg)	lbs	(kg)	A	B	C			
Imperial	3510-05	0.5	(12,7)	17.0	(7,6)	0.10	(0,045)	1.68	(42,7)	1.25	(31,8)	1.25	(31,8)
	3510-10	1.0	(25,4)	29.0	(13,1)	0.12	(0,054)	2.68	(68,1)	2.25	(57,2)	2.25	(57,2)
	3510-20	2.0	(50,8)	36.0	(16,3)	0.14	(0,064)	3.68	(93,5)	3.25	(82,6)	3.25	(82,6)



3511 Series

Specifications

Travel:	0.75 – 4.0 in
Size:	
Width	1.06 in
Length	1.68 – 6.68 in
Height	0.53 in
Load:	
Normal	14.6 – 56 lbs
Moment: Yaw, Pitch, Roll	See page 30
Straight line accuracy:	0.00025 in/in of travel
Metric thread option:	M2 x 0,4 (consult factory)
Construction:	Aluminum top and base/ 440C stainless steel bearings
Mounting surface:	Precision machined
Finish:	Black anodize



Dimensions in (mm)

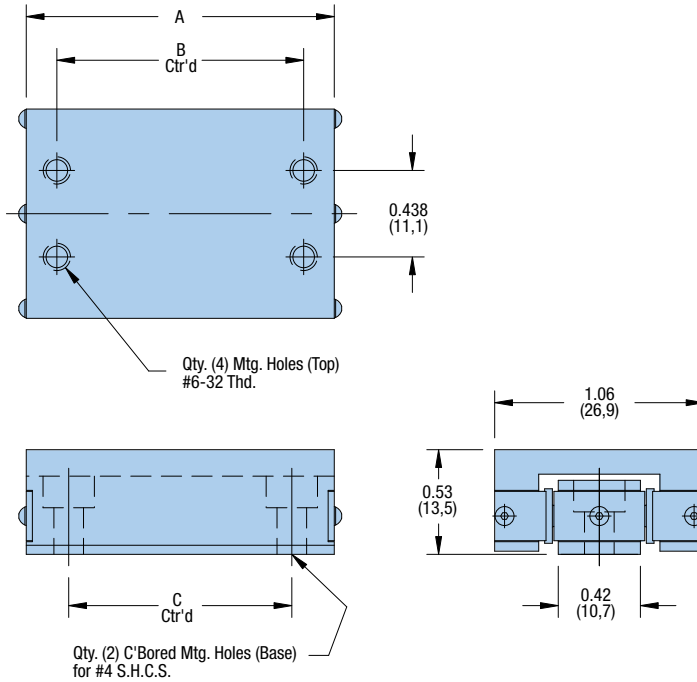

	Dimensions												
	Travel		Normal Load		Weight		A		B		C		
	Model	in	(mm)	lbs	(kg)	lbs	(kg)	in	(mm)	in	(mm)	in	(mm)
Imperial	3511-07	0.75	(19,1)	14.6	(6,6)	0.08	(0,036)	1.68	(42,7)	1.25	(31,8)	1.13	(28,7)
	3511-15	1.5	(38,1)	24.3	(11,0)	0.14	(0,064)	2.68	(68,1)	2.25	(57,2)	2.13	(54,1)
	3511-20	2.0	(50,8)	36.0	(16,3)	0.20	(0,091)	3.68	(93,5)	3.25	(82,6)	3.13	(79,5)
	3511-30	3.0	(76,2)	43.0	(19,5)	0.26	(0,118)	4.68	(118,9)	4.00	(101,6)	3.25	(82,6)
	3511-40	4.0	(101,6)	56.0	(25,4)	0.32	(0,145)	6.68	(169,7)	5.50	(139,7)	4.00	(101,6)

3900/M3900 Series

Specifications	Imperial	Metric
Travel:	0.5 in	12,7 mm
Size:		
Width	1.25 in	31,8 mm
Length	1.25 in	31,8 mm
Height	0.50 in	12,7 mm
Load:		
Normal	6 lbs	2,7 kg
Moment: Yaw, Pitch, Roll	See page 31	See page 31
Straight line accuracy:	0.00008 in/in of travel	2 µm/25 mm of travel
Weight:	0.1 lbs	0,05 kg
Construction:	Aluminum top and base/ 440C stainless steel bearings	
Mounting surface:	Precision machined	
Finish:	Black anodize	

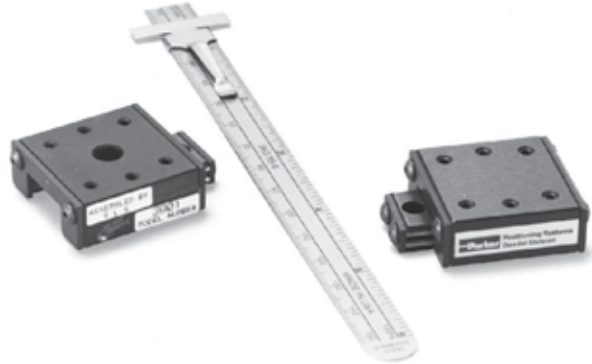

Dimensions in (mm)

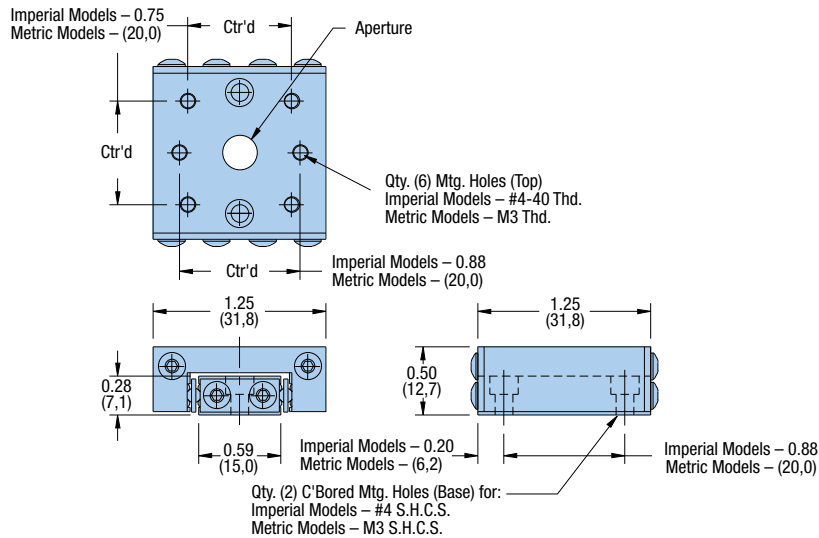

	Model	Travel	Aperture
Imperial	3901	0.5 in	0.25 in
	3905	0.5 in	—
Metric	M3901	12,7 mm	6,35 mm
	M3905	12,7 mm	—



4000/M4000 Series

Specifications	Imperial	Metric
Travel:	1.0 in	25,4 mm
Size:		
Width	1.75 in	44,5 mm
Length	1.75 in	44,5 mm
Height	0.75 in	19,0 mm
Load:		
Normal	25 lbs	11 kg
Moment: Yaw, Pitch, Roll	See page 31	See page 31
Straight line accuracy:	0.00008 in/in of travel	2 µm/25 mm of travel
Weight:	0.2 lbs	0,09 kg
Construction:	Aluminum top and base/ 440C stainless steel bearings	
Mounting surface:	Precision machined	
Finish:	Black anodize	



Ball Bearing Slides

Dimensions in (mm)

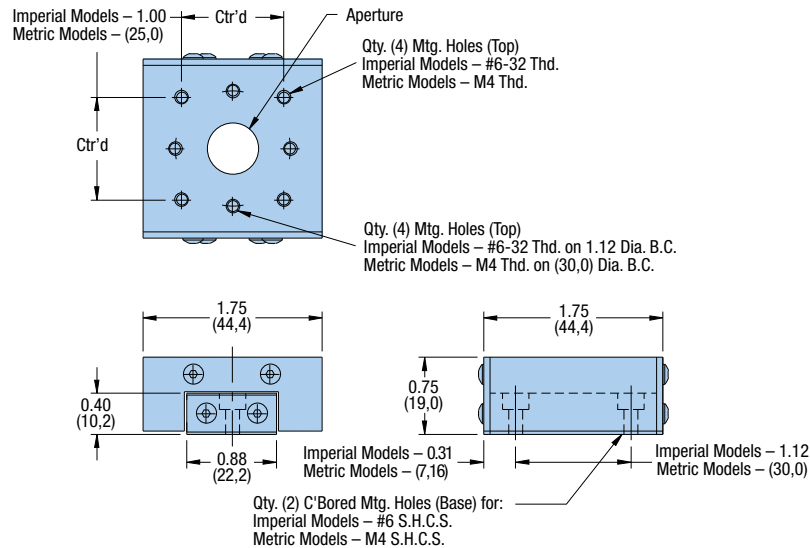

Model	Travel	Aperture
Imperial	4001	1.0 in
	4005	1.0 in
Metric	M4001	25,4 mm
	M4005	25,4 mm

4100/M4100, 4200/M4200, 4300/M4300 Series

Specifications	Imperial	Metric
Travel:	1.0 – 3.0 in	25,4 – 76,2 mm
Size:		
Width	1.75 in	44,5 mm
Length	2.00 – 4.00 in	50,8 – 101,6 mm
Height	0.75 in	
Load:		
Normal	28 – 55 lbs	13 – 25 kg
Moment: Yaw, Pitch, Roll	See page 31	See page 31
Straight line accuracy:	0.00008 in/in of travel	2 µm/25 mm of travel
Weight:	0.2 – 0.6 lbs	0,09 – 0,27 kg
Construction:	Aluminum top and base/ 440C stainless steel bearings	
Mounting surface:	Precision machined	
Finish:	Black anodize	



Dimensions in (mm)

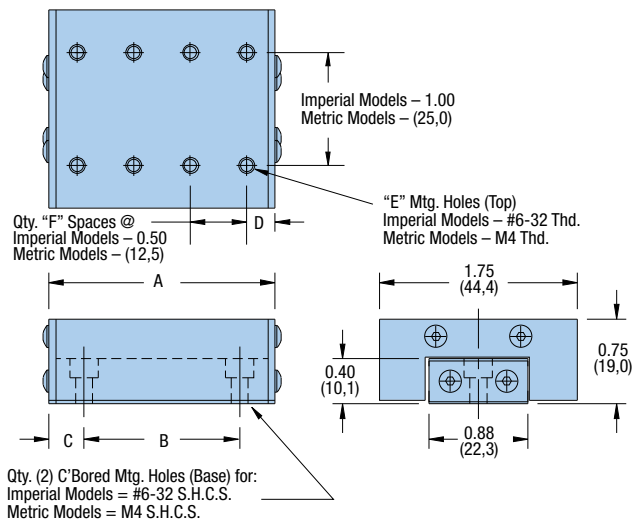

Model	Travel	Normal Load	Weight	Dimensions						
				A	B	C	D	E	F	
Imperial	4101	1.0 in	28 lbs	0.2 lbs	2.00 in	1.38 in	0.31 in	0.25 in	8	3
	4201	2.0 in	40 lbs	0.4 lbs	3.00 in	2.38 in	0.31 in	0.25 in	12	5
	4301	3.0 in	55 lbs	0.6 lbs	4.00 in	3.38 in	0.31 in	0.25 in	16	7
Metric	M4101	25,4 mm	13 kg	0,09 kg	50,8 mm	35,0 mm	7,8 mm	12,9 mm	6	2
	M4201	50,8 mm	18 kg	0,18 kg	76,2 mm	60,0 mm	8,1 mm	13,1 mm	10	4
	M4301	76,2 mm	25 kg	0,27 kg	101,6 mm	85,0 mm	8,3 mm	13,3 mm	14	6



4500/M4500 Series

Specifications	Imperial	Metric
Travel:	1.0 in	25,4 mm
Size:		
Width	2.62 in	66,5 mm
Length	2.62 in	66,5 mm
Height	1.00 in	25,4 mm
Load:		
Normal	62 lbs	28 kg
Moment: Yaw, Pitch, Roll	See page 31	See page 31
Straight line accuracy:	0.00008 in/in of travel	2 μm/25 mm of travel
Weight:	4501 – 0.6 lbs 4505 – 0.5 lbs	M4501 – 0,27 kg M4505 – 0,23 kg
Construction:	Aluminum top and base/ 440C stainless steel bearings	
Mounting surface:	Precision machined	
Finish:	Black anodize	



Dimensions in (mm)

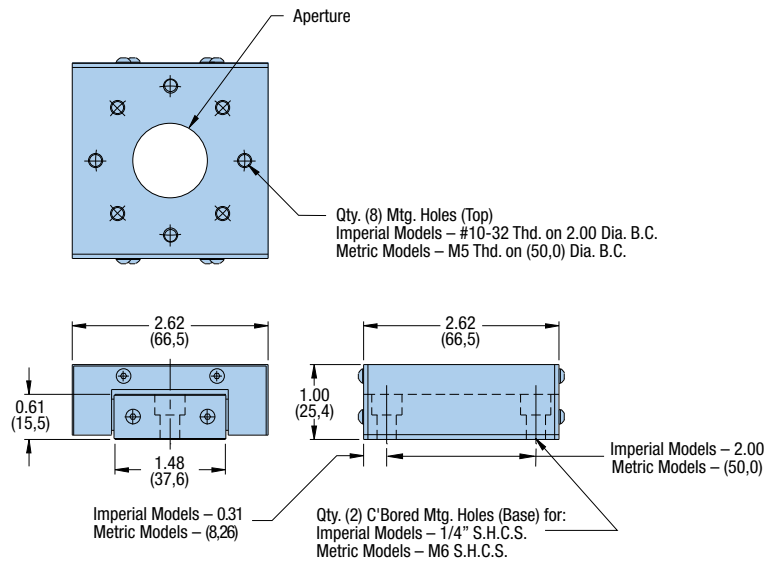

Model	Travel	Aperture
Imperial	4501	1.0 in
	4505	1.0 in
Metric	M4501	25,4 mm
	M4505	25,4 mm

4600/M4600, 4700/M4700, 4800/M4800 Series

Specifications	Imperial	Metric
Travel:	2.0 – 4.0 in	50,8 – 101,6 mm
Size:		
Width	2.62 in	66,5 mm
Length	4.00 – 6.00 in	101,6 – 152,4 mm
Height	1.00 in	
Load:		
Normal	88 – 123 lbs	40 – 56 kg
Moment: Yaw, Pitch, Roll	See page 32	See page 32
Straight line accuracy:	0.00008 in/in of travel	2 µm/25 mm of travel
Weight:	0.9 – 1.4 lbs	0,41 – 0,64 kg
Construction:	Aluminum top and base/ 440C stainless steel bearings	
Mounting surface:	Precision machined	
Finish:	Black anodize	



Dimensions in (mm)

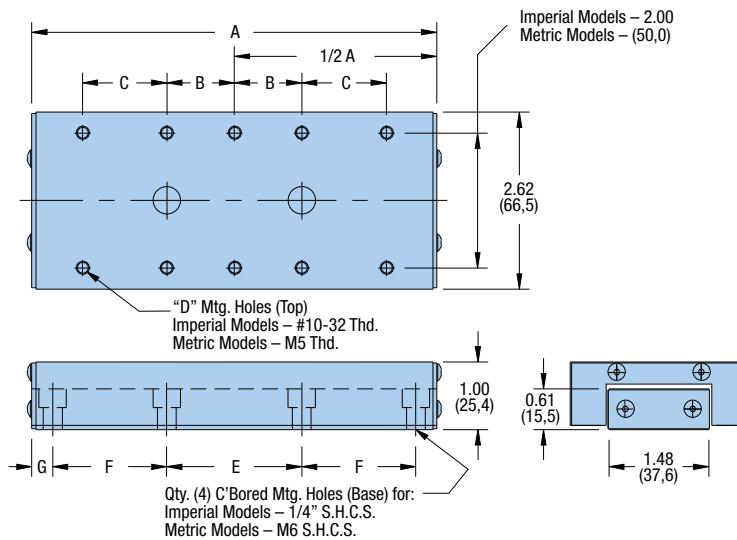

Model	Travel	Normal Load	Weight	Dimensions							
				A	B	C	D	E	F	G	
Imperial	4601	2.0 in	88 lbs	0.9 lbs	4.00 in	0.5 in	—	6	2.00 in	0.69 in	0.31 in
	4701	3.0 in	100 lbs	1.1 lbs	5.00 in	1.0 in	—	6	2.00 in	1.19 in	0.31 in
	4801	4.0 in	123 lbs	1.4 lbs	6.00 in	0.5 in	1.0 in	10	2.00 in	1.69 in	0.31 in
Metric	M4601	50,8 mm	40 kg	0,41 kg	101,6 mm	12,5 mm	—	6	50,0 mm	12,5 mm	13,3 mm
	M4701	76,2 mm	48 kg	0,50 kg	127,0 mm	25,0 mm	—	6	50,0 mm	25,0 mm	13,5 mm
	M4801	101,6 mm	56 kg	0,64 kg	152,4 mm	12,5 mm	25,0 mm	10	50,0 mm	25,0 mm	26,2 mm



4600 Series

Specifications	
Travel:	6.0 – 15.0 in
Size:	
Width	2.62 in
Length	9.00 – 18.00 in
Height	1.00 in
Load:	
Normal	154 – 243 lbs
Moment: Yaw, Pitch, Roll	See page 32-33
Straight line accuracy:	0.00008 in/in of travel
Weight:	2.3 – 4.7 lbs
Construction:	Aluminum top and base/ 440C stainless steel bearings
Mounting surface:	Precision machined
Finish:	Black anodize



Dimensions in (mm)

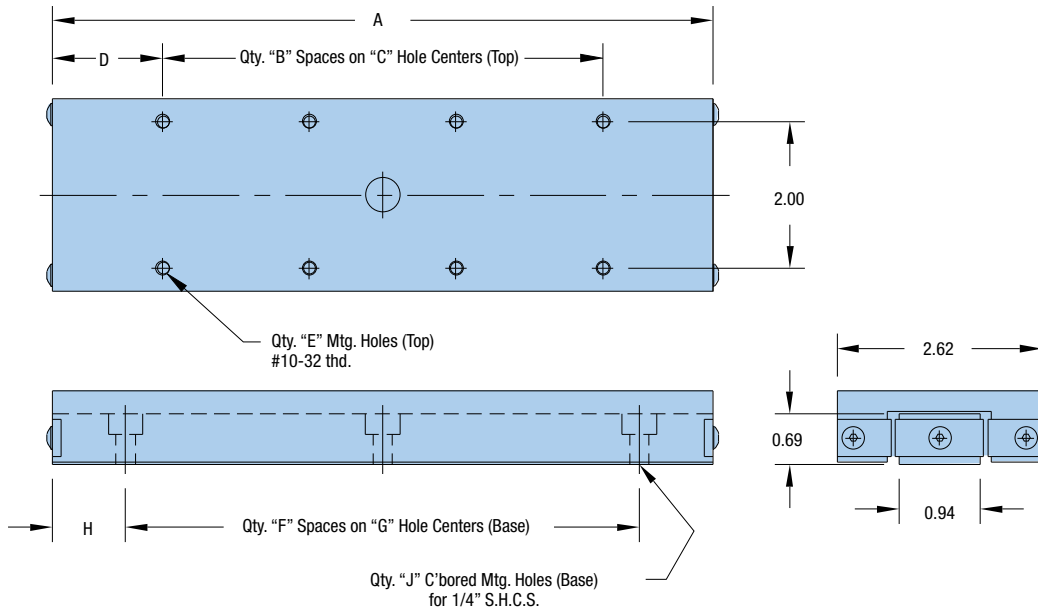

				Dimensions – in									
Model	Travel in	Normal Load lbs	Weight lbs	A	B	C	D	E	F	G	H	J	
Imperial	4606	6.0	154	2.3	9.00	3	2.00	1.50	8	2	3.50	1.00	3
	4609	9.0	192	3.1	12.00	5	2.00	1.00	12	2	5.00	1.00	3
	4612	12.0	205	3.9	15.00	6	2.00	1.50	14	4	3.25	1.00	5
	4615	15.0	243	4.7	18.00	8	2.00	1.00	18	4	4.00	1.00	5

4400/M4400 Series

Specifications	Imperial	Metric
Travel:	3.0 in	76,2 mm
Size:		
Width	5.00 in	127,0 mm
Length	5.00 in	127,0 mm
Height	1.00 in	25,4 mm
Load:		
Normal	106 lbs	48 kg
Moment: Yaw, Pitch, Roll	See page 31	See page 31
Straight line accuracy:	0.00008 in/in of travel	2 µm/25 mm of travel
Weight:	4410 – 2.2 lbs 4450 – 1.7 lbs	M4410 – 1,00 kg M4450 – 0,77 kg
Construction:	Aluminum top and base/ 440C stainless steel bearings	
Mounting surface:	Precision machined	
Finish:	Black anodize	

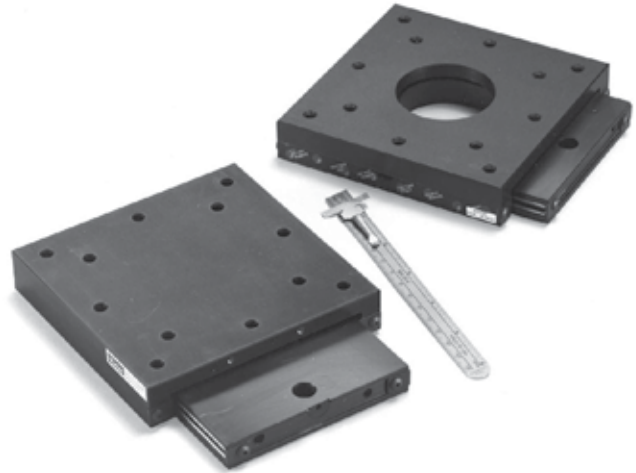

Dimensions in (mm)

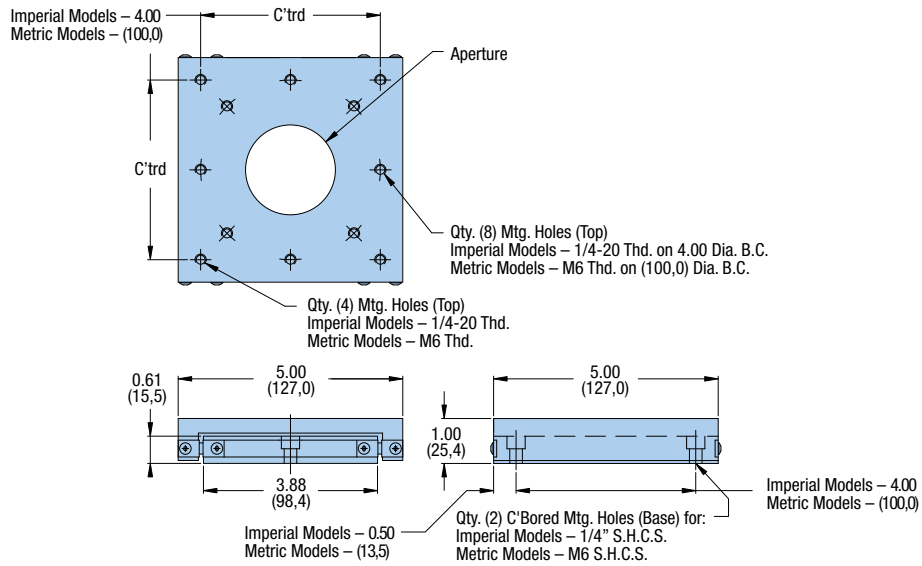

	Model	Travel	Aperture
Imperial	4410	3.0 in	—
	4450	3.0 in	2.00 in
Metric	M4410	76,2 mm	—
	M4450	76,2 mm	50,8 mm



4900/M4900 Series

Specifications	Imperial	Metric
Travel:	2.0 in	50,8 mm
Size:		
Width	5.00 in	127,0 mm
Length	5.00 in	127,0 mm
Height	1.75 in	44,5 mm
Load:		
Normal	77 lbs	35 kg
Moment: Yaw, Pitch, Roll	See page 34	See page 34
Straight line accuracy:	0.00008 in/in of travel	2 µm/25 mm of travel
Weight:	3.0 lbs	1,4 kg
Construction:	Aluminum top and base/ 440C stainless steel bearings	
Mounting surface:	Precision machined	
Finish:	Black anodize	

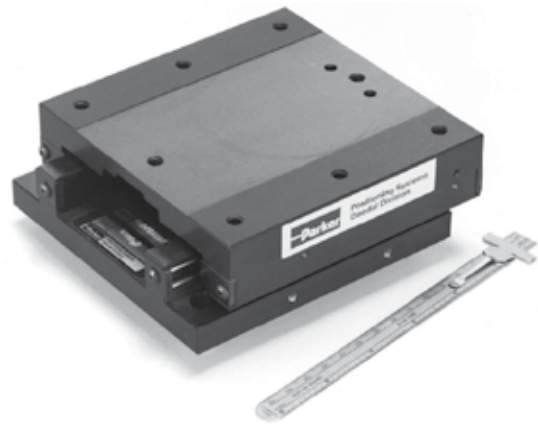

Dimensions in (mm)

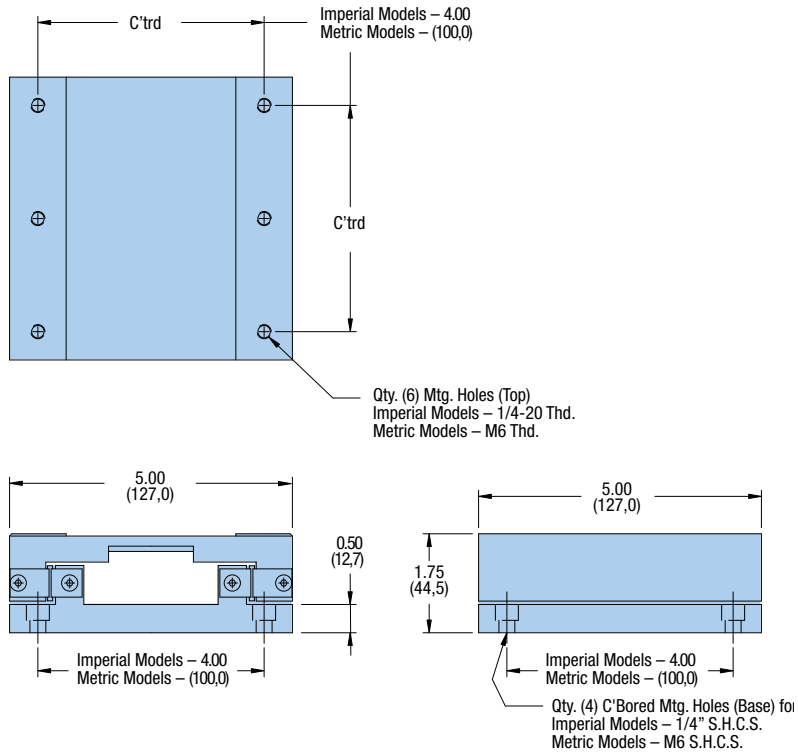

	Model	Travel
Imperial	4900-02	2.0 in
Metric	M4900-02	50,8 mm

4900/M4900 Series

Specifications	Imperial	Metric
Travel:	4.0 – 12.0 in	101,6 – 304,8 mm
Size:		
Width	6.00 in	152,4 mm
Length	6.00 – 18.00 in	152,4 – 457,2 mm
Height	2.00 in	50,8 mm
Load:		
Normal	100 – 294 lbs	45 – 133 kg
Moment: Yaw, Pitch, Roll	See page 34	See page 34
Straight line accuracy:	0.00008 in/in of travel	2 µm/25 mm of travel
Weight:	5.0 – 13.0 lbs	2,3 – 6,0 kg
Construction:	Aluminum top and base/ 440C stainless steel bearings	
Mounting surface:	Precision machined	
Finish:	Black anodize	



Dimensions in (mm)

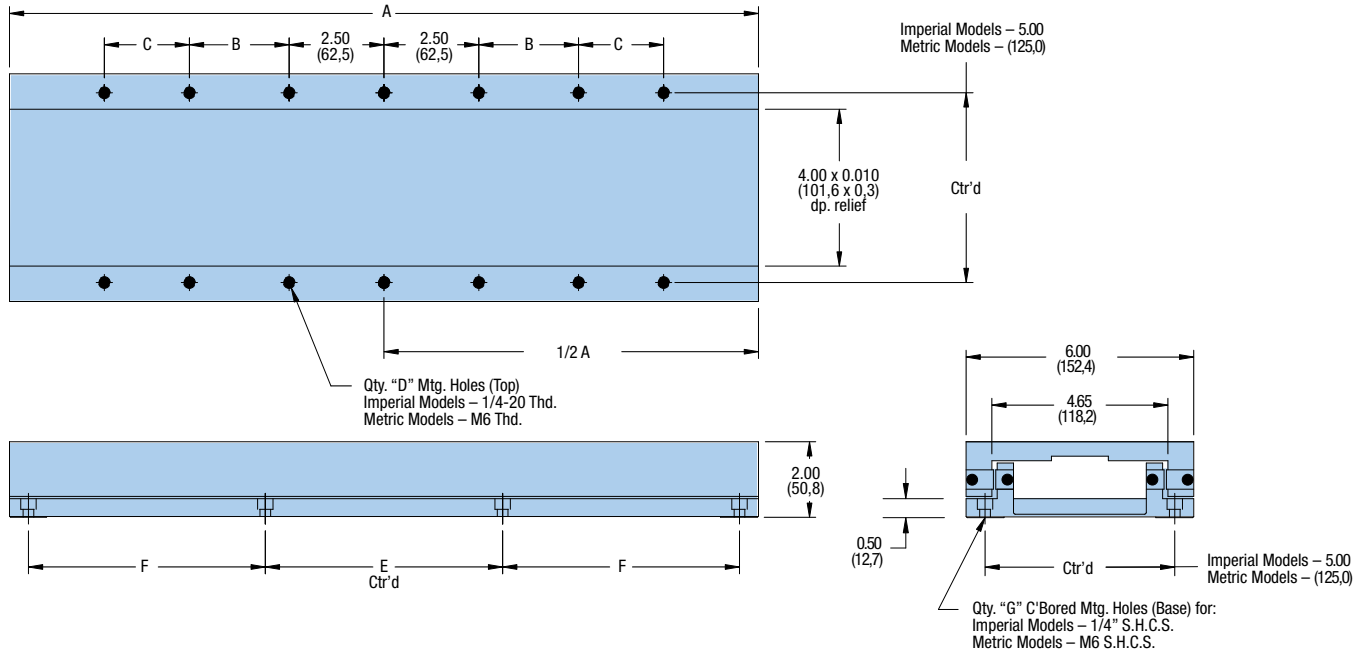

Model	Travel	Normal Load	Weight	Dimensions							
				A	B	C	D	E	F	G	
Imperial	4900-04	4.0 in	100 lbs	5.0 lbs	6.00 in	—	—	6	5.00 in	—	4
	4900-06	6.0 in	154 lbs	7.0 lbs	9.00 in	1.50 in	—	10	5.00 in	1.50 in	8
	4900-08	8.0 in	205 lbs	9.0 lbs	12.00 in	2.50 in	—	10	5.00 in	3.00 in	8
	4900-10	10.0 in	243 lbs	11.0 lbs	15.00 in	2.50 in	2.00 in	14	6.00 in	4.00 in	8
	4900-12	12.0 in	294 lbs	13.0 lbs	18.00 in	5.00 in	1.00 in	14	7.00 in	5.00 in	8
Metric	4900-04	101,6 mm	45 kg	2,3 kg	152,4 mm	—	—	6	125,0 mm	—	4
	4900-06	152,4 mm	70 kg	3,0 kg	228,6 mm	37,5 mm	—	10	125,0 mm	37,5 mm	8
	4900-08	203,2 mm	93 kg	4,0 kg	304,8 mm	62,5 mm	—	10	125,0 mm	75,0 mm	8
	4900-10	254,0 mm	110 kg	5,0 kg	381,0 mm	62,5 mm	50,0 mm	14	150,0 mm	100,0 mm	8
	4900-12	304,8 mm	133 kg	6,0 kg	457,2 mm	125,0 mm	25,0 mm	14	175,0 mm	125,0 mm	8



Yaw, Pitch, Roll

Yaw & Pitch Roll

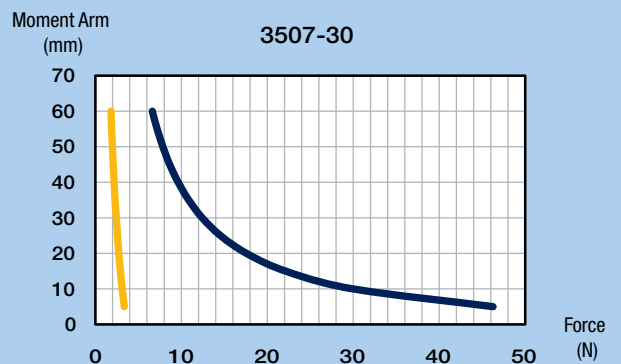
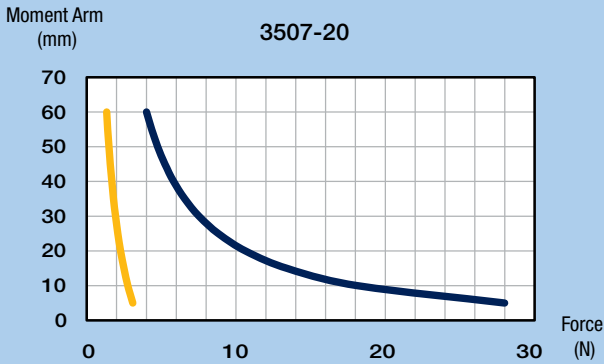
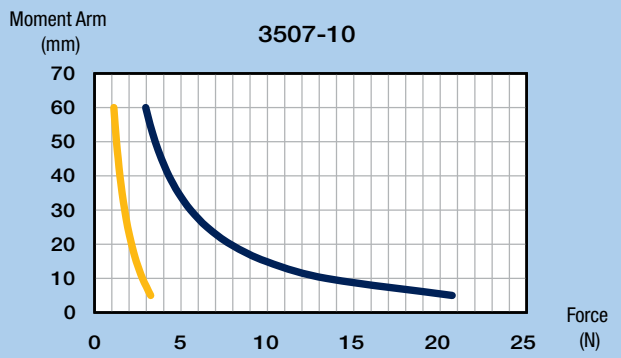
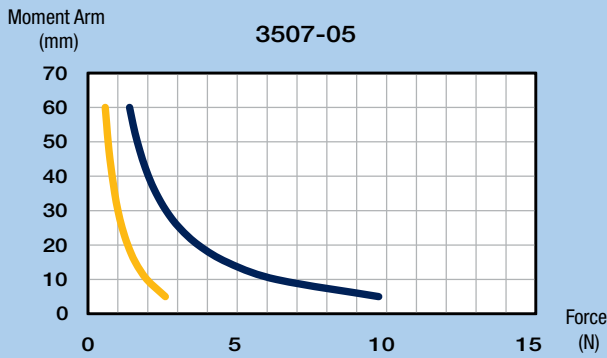
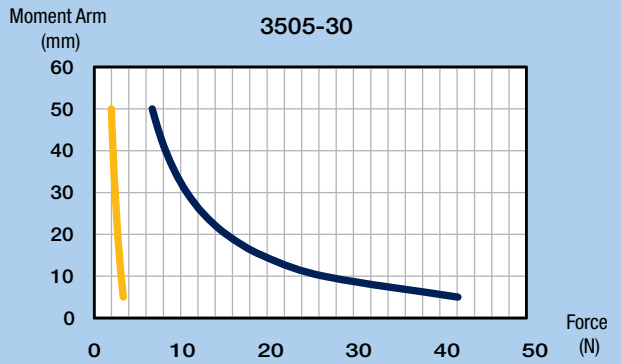
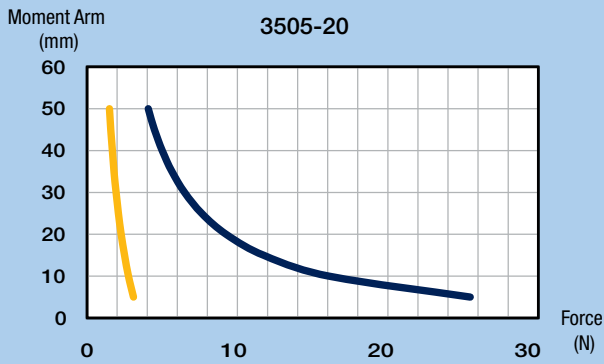
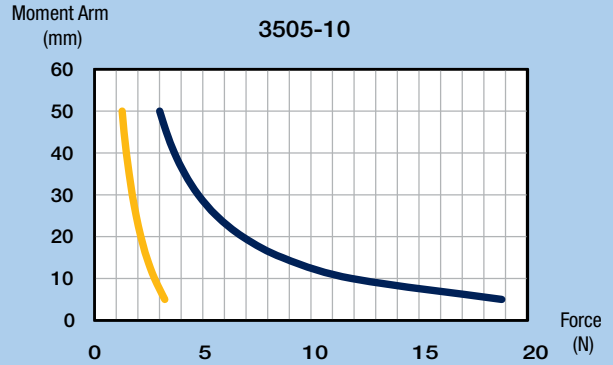
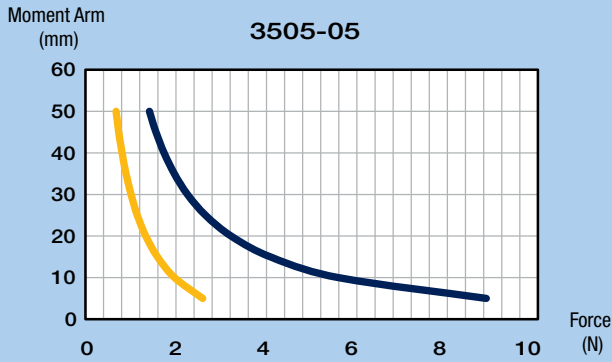

Yaw, Pitch, Roll

Yaw & Pitch Roll

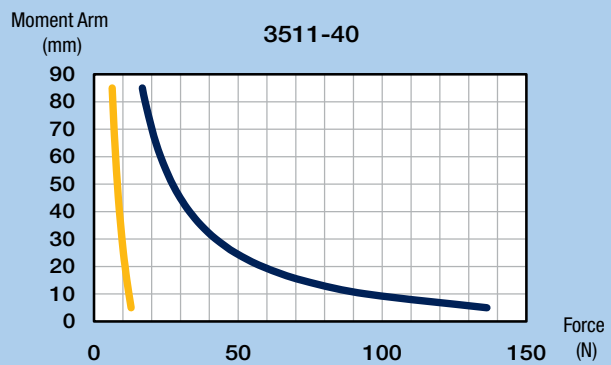
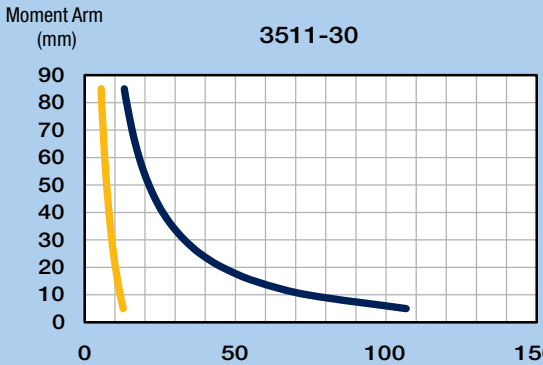
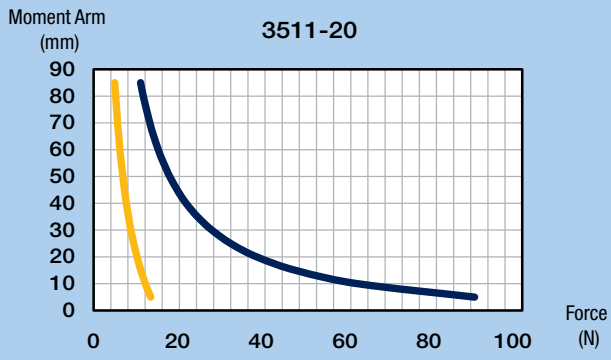
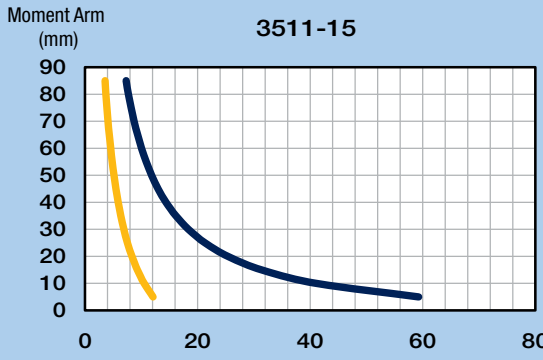
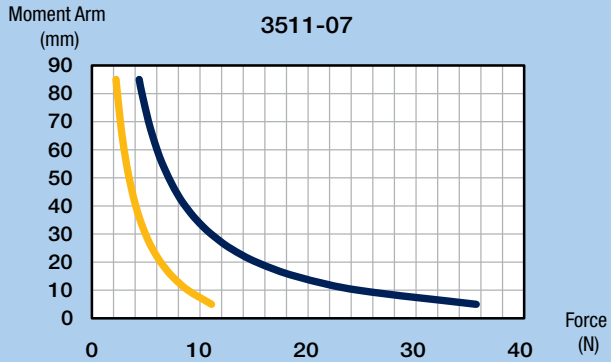
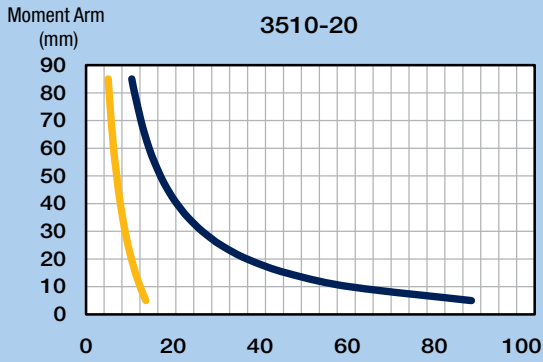
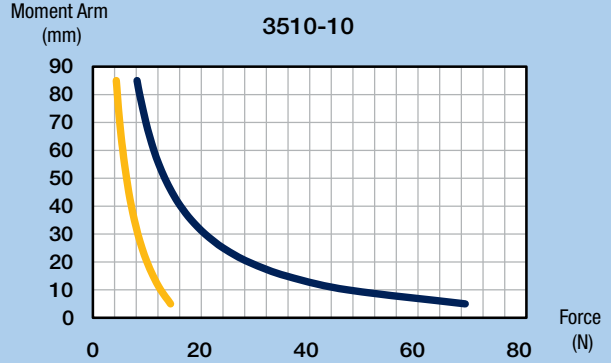
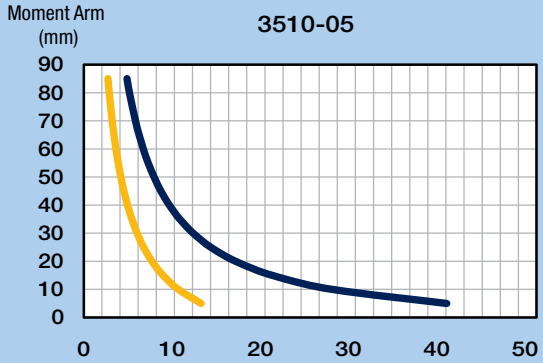



Yaw, Pitch, Roll

Yaw & Pitch Roll

3901/M3901 & 3905/M3905

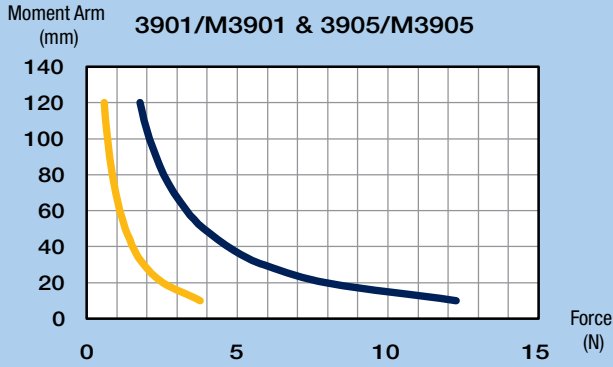

4001/M4001 & 4005/M4005

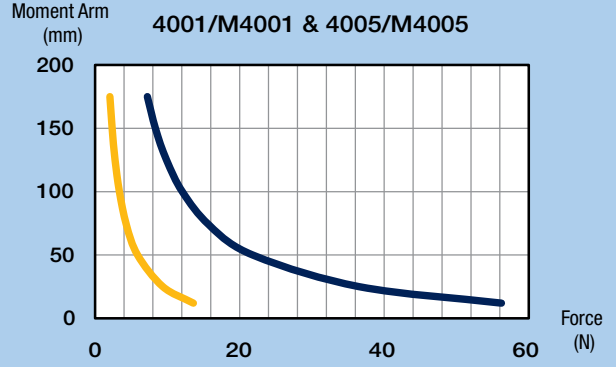

4101/M4101 & 4005/M4005

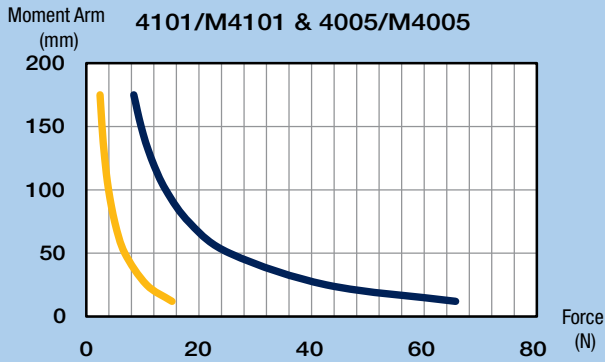

4201/M4201

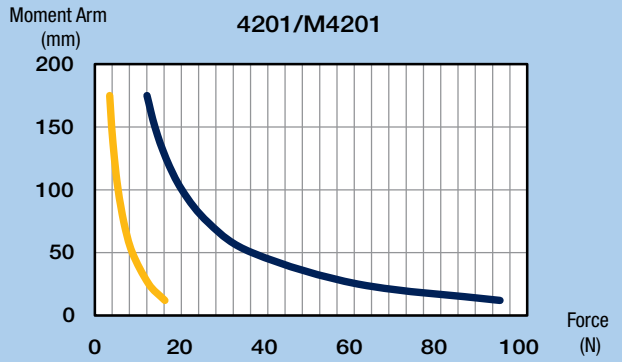

4301/M4301

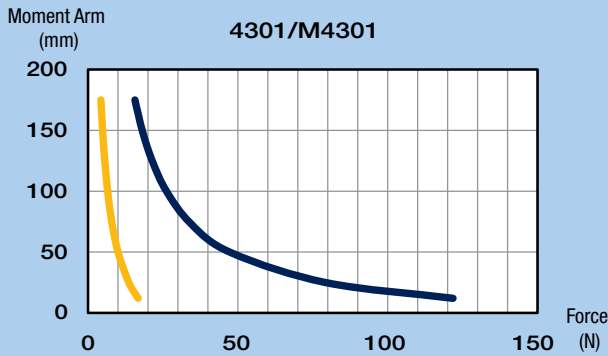

4410/M4410 & 4450/M4450

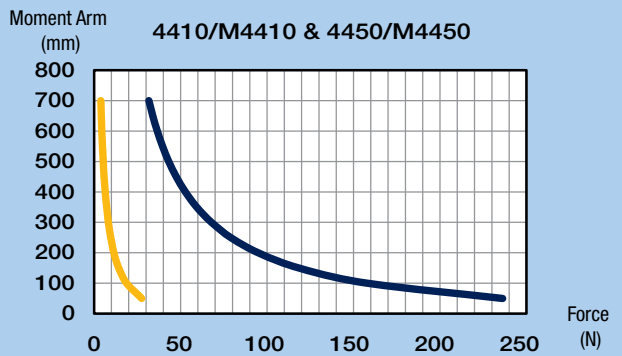

4501/M4501 & 4505/M4505

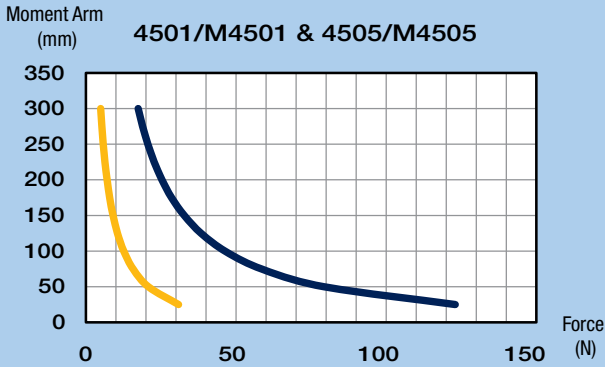

Yaw, Pitch, Roll

Yaw & Pitch Roll

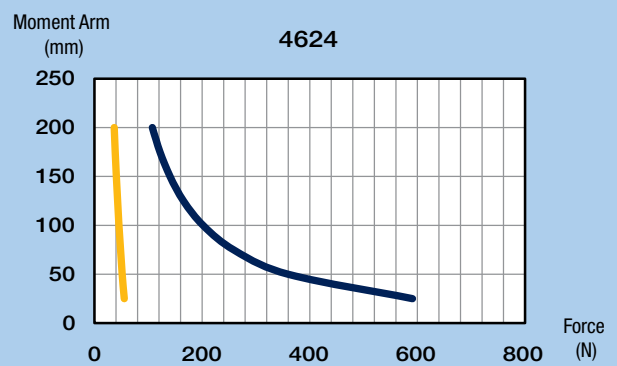
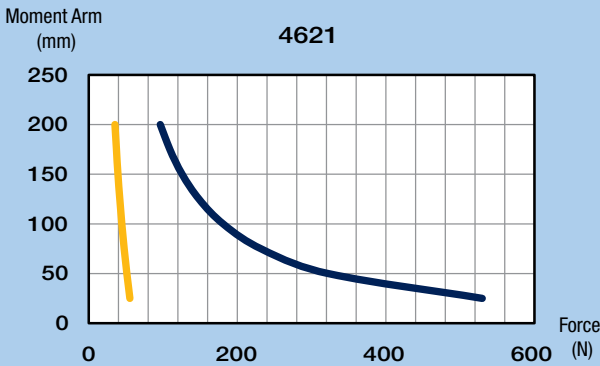
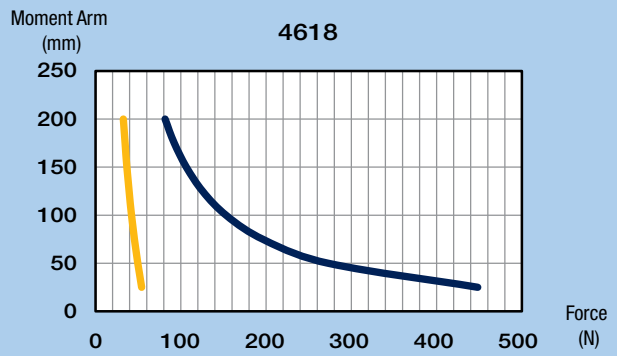
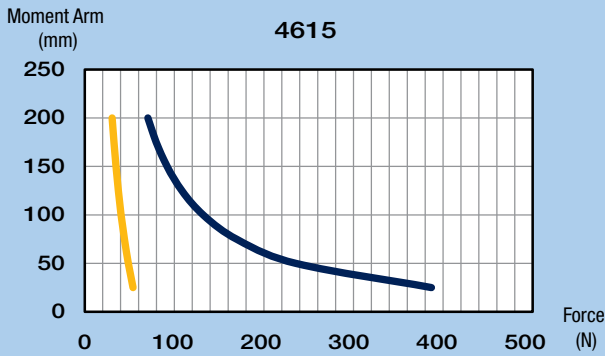
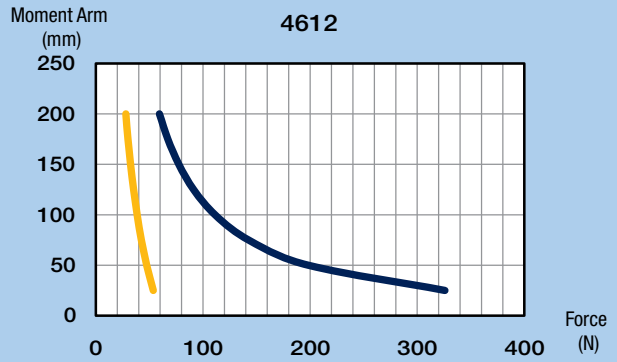
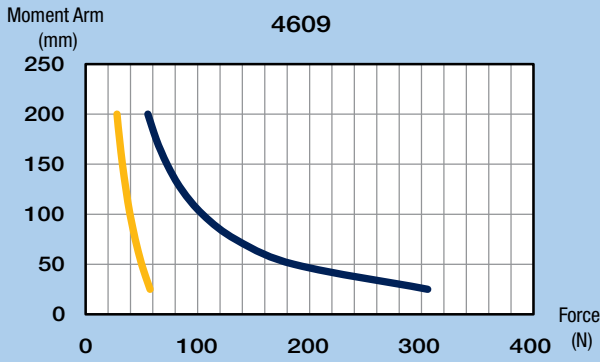
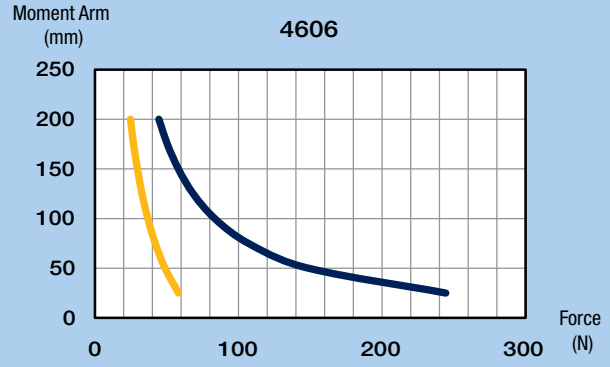
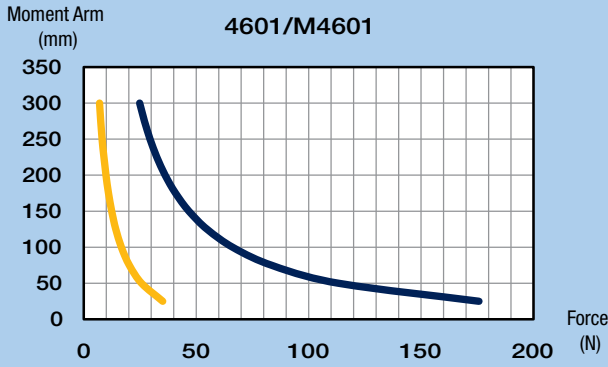

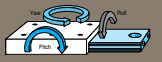

Yaw, Pitch, Roll

Yaw & Pitch Roll

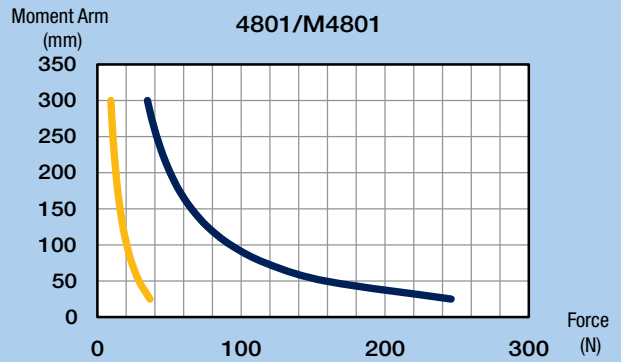
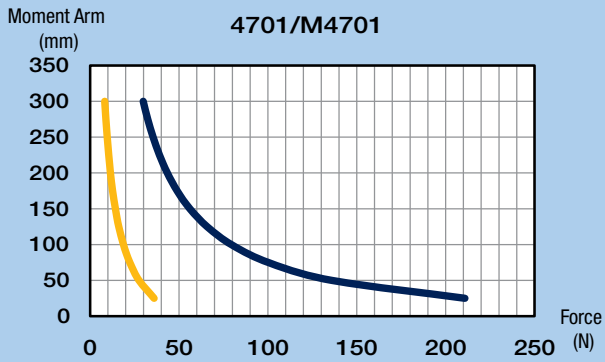
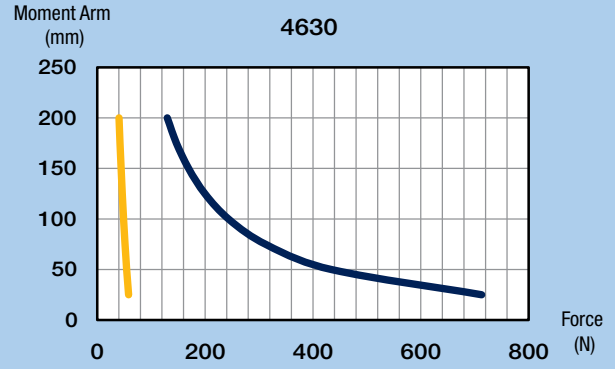
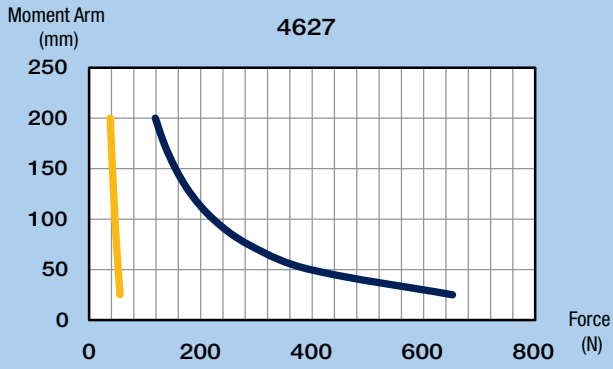

Yaw, Pitch, Roll

Yaw & Pitch Roll

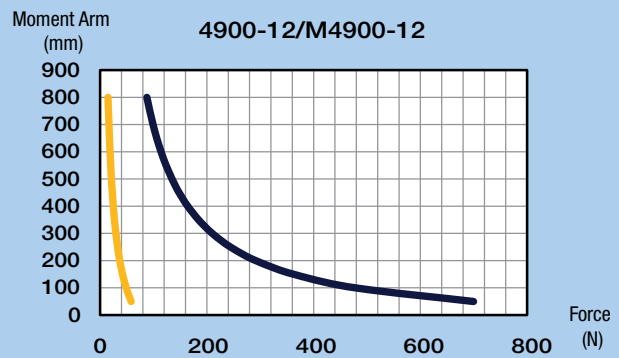
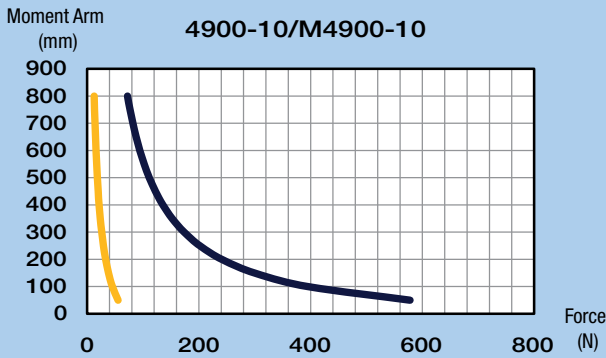
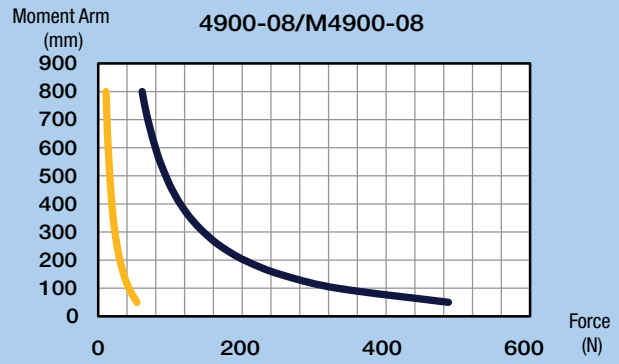
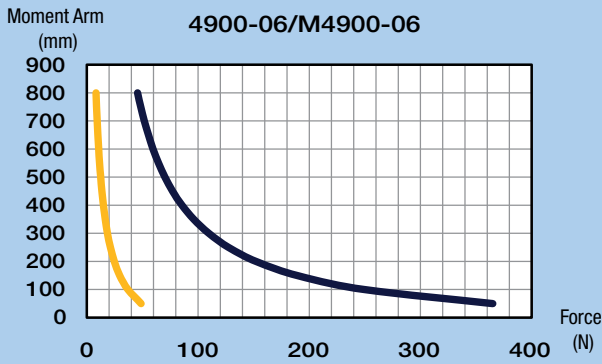
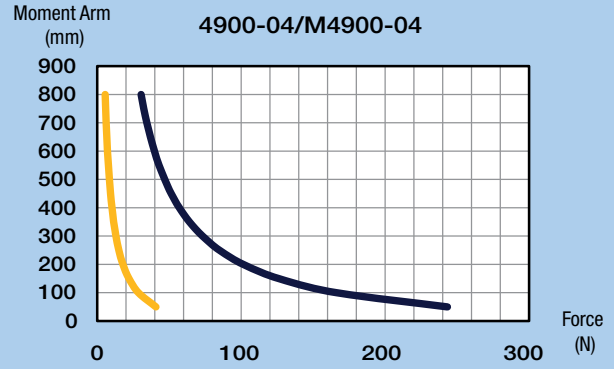
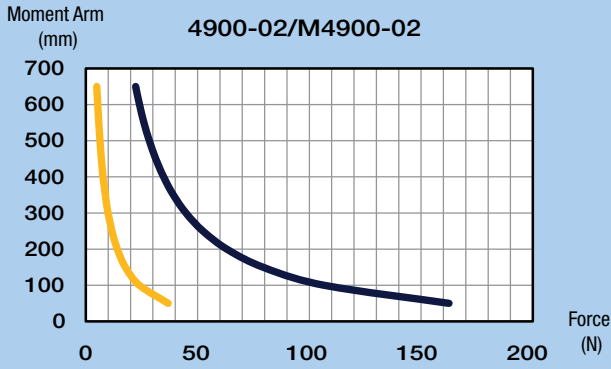

Crossed Roller Slides

Heavy load capacity, Long life

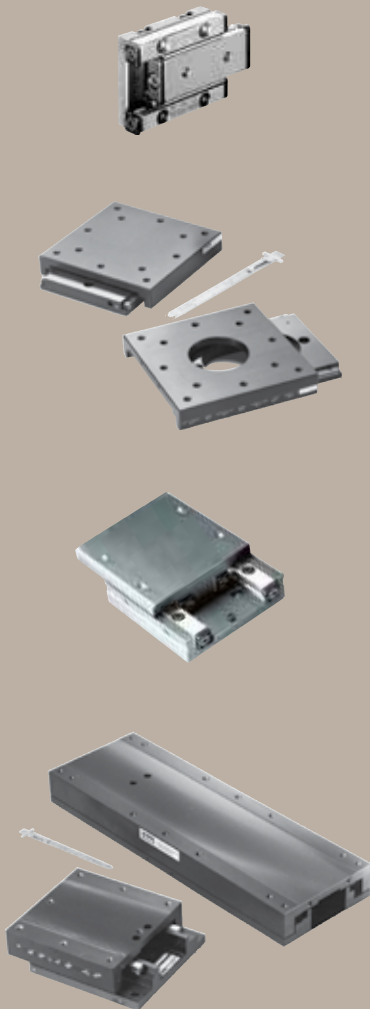

Crossed roller slides offer exceptional load carrying capability of approximately twice that of comparably sized ball slides. Additionally, crossed roller slides provide up to five times the life expectancy of ball slides without degradation to performance. Parker crossed roller slides are rated for over 100 million inches of travel at specified load.

Contents

36-38	Overview
39	1.496" (38,0 mm) Wide
40-41	1.75" (44,5 mm) Wide
42-43	1.97" (50,0 mm) Wide
44-45	2.62" (66,5 mm) Wide
46-47	2.95" (75,0 mm) Wide
48-49	3.94" (100,0 mm) Wide
50	5.00" (127,0 mm) Wide
51	6.00" (152,4 mm) Wide
52-60	Performance Curves

Heavy Load Capacity Crossed Roller Slides



- Precision quality
- Budget friendly
- Largest selection
- Easy multi-axis configuration
- No maintenance
- Vacuum preparation and custom options

Crossed Roller Slide Design Principles

The crossed roller slide bearing system is composed of two rows of rollers. Each roller is alternately crossed at 90° with the next and captured in “V” grooves, located on the base and top. Since rollers provide a larger (line) contact surface than ball bearings, a crossed roller slide has higher load carrying capability than a ball slide of comparable size.

Crossed roller slides are constructed of corrosion-resistant black anodized aluminum and high carbon steel. These building materials provide optimized stiffness and thermal stability without excessive mass. Members are precision machined to assure flatness and parallelism for both top and bottom mounting surfaces.

Crossed roller slides are preloaded during the manufacturing process to eliminate any side play and to provide a uniform coefficient of friction. Like the ball slide, the crossed roller slide is not suggested for use in shock load applications.

Our large-scale manufacturing enables us to offer precision quality crossed roller slides at commercial quality prices.

Standard Features

All models offer high-quality construction features as standard:

- Straight line accuracy of 0.00008 inches per inch of travel (0.00025 inches per inch of travel for miniatures)
- Precision machined mounting surfaces to assure flatness and parallelism
- Factory preloaded to precision specifications to eliminate any side play and provide a uniform coefficient of friction
- Factory threaded mounting holes on the top for easy payload mounting
- Factory machining services for special hole configurations and custom modifications
- Locking thread inserts on preloaded screws for maintenance-free life without loss of preload
- Hardened and precision machined rollers and ways

How to Order

Use the overview chart on the following page to select the appropriate crossed roller slide series with the appropriate load and travel. Refer to the series specification page for complete performance and mechanical information. To order, use the model number corresponding to the travel length required. A variety of modifications to standard models are available to meet custom requirements. Contact our application engineering department with your design specifications.

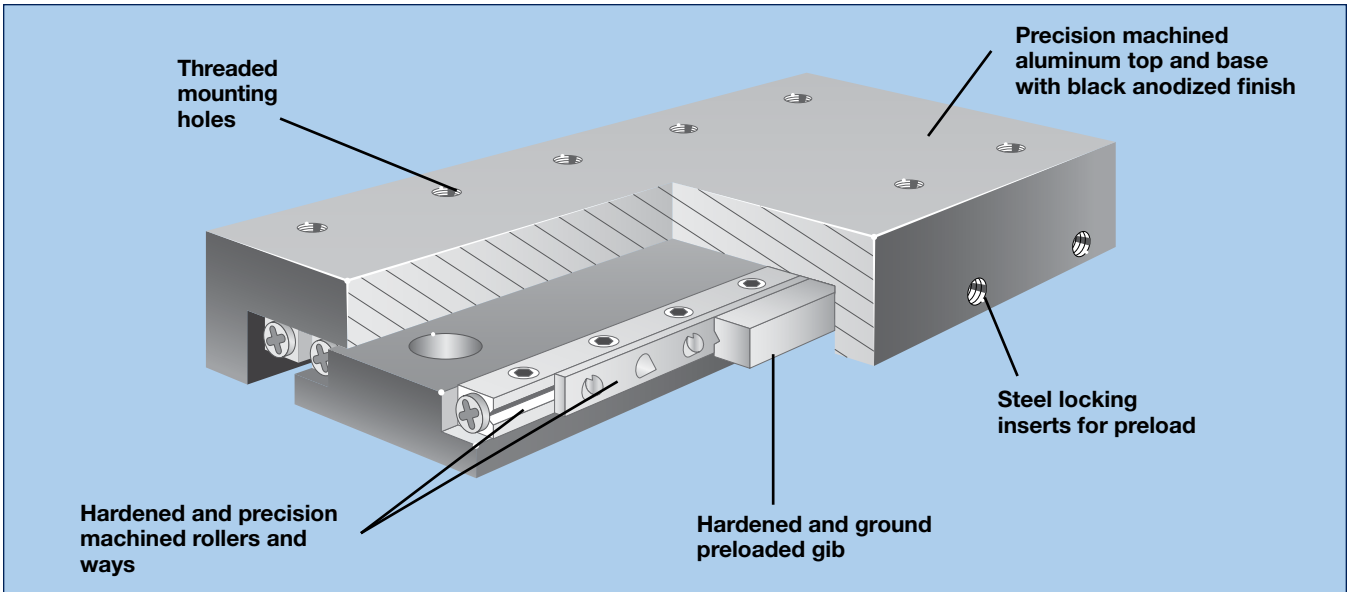

Product Configurations

(see following page for selection overview)

SW Series

Double "V" Low Profile Slides
Metric Mounting Only



CR and SE Series

Extended Travel Slides
Imperial Mounting (CR)
Metric Mounting (SE)



SP Series

Limited Travel Slides
Metric Mounting Only

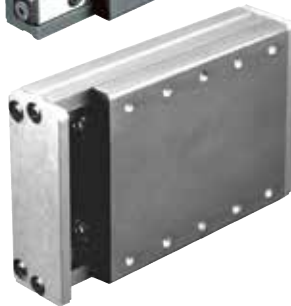

Mounting Orientations

(see Accessory section for details for Z-brackets)

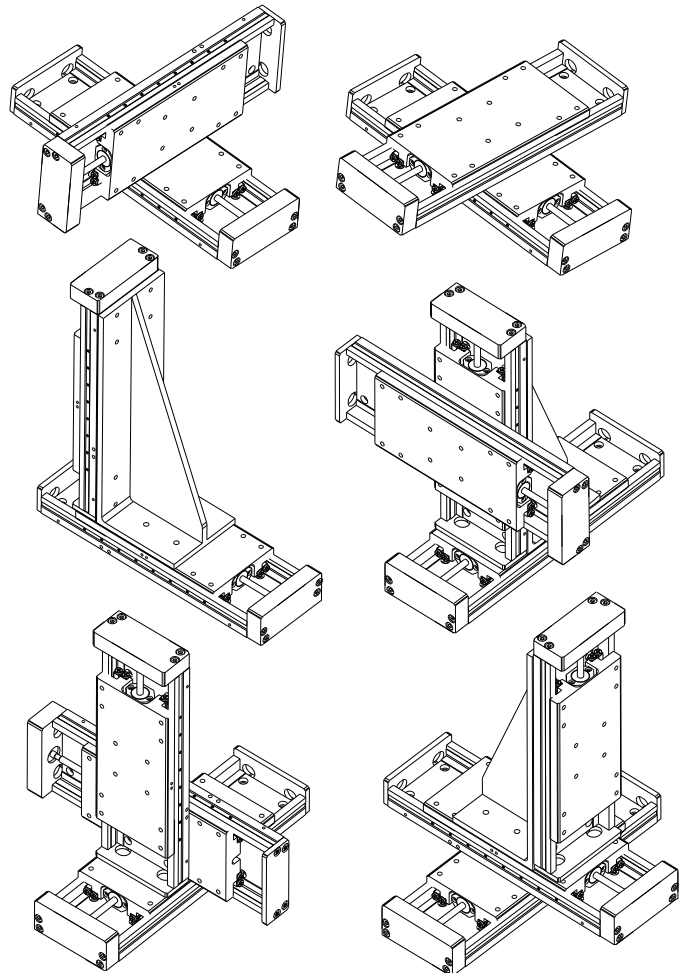

Selection

Series	Width in (mm)	Travel		Normal Load		Mounting		Page
		in	(mm)	lbs	(kg)	Imperial	Metric	
SW038	1.496 (38,0)	0.98	(25)	213	(97)		•	39
		1.97	(50)	263	(119)		•	39
		2.95	(75)	351	(159)		•	39
		3.94	(100)	439	(199)		•	39
		4.92	(125)	527	(239)		•	39
		5.91	(150)	614	(278)		•	39
		7.87	(200)	789	(358)		•	39
CR4000 CR4100 CR4200 CR4300	1.75 (44,5)	1.00	(25,4)	81	(37)	•		40-41
		2.00	(50,8)	121	(55)	•		41
		3.00	(76,2)	131	(59)	•		41
SE050 SP050	1.97 (50,0)	0.98	(25)	175	(80)		•	42-43
		1.97	(50)	263	(119)		•	42-43
		2.95	(75)	351	(159)		•	42-43
		3.94	(100)	439	(199)		•	42
		4.92	(125)	527	(239)		•	42
		5.91	(150)	614	(278)		•	42
		7.87	(200)	789	(358)		•	42
CR4500 CR4600 CR4700 CR4800	2.62 (66,5)	1.0	(25,4)	111	(50)	•		44
		2.0	(50,8)	151	(69)	•		45
		3.0	(76,2)	201	(91)	•		45
		4.0	(101,6)	252	(114)	•		45
SE075 SP075	2.95 (75,0)	1.97	(50)	263	(119)		•	46
				348	(158)		•	47
		2.95	(75)	351	(159)		•	46
				439	(199)		•	47
		3.94	(100)	439	(199)		•	46
		4.92	(125)	527	(239)		•	46
		5.91	(150)	614	(278)		•	46
7.87	(200)	789	(358)		•	46		
SE100 SP100	3.94 (100,0)	0.98	(25)	439	(199)		•	49
		1.97	(50)	527	(239)		•	49
		2.95	(75)	795	(361)		•	48
				614	(278)		•	49
		3.94	(100)	702	(318)		•	49
		4.92	(125)	1236	(561)		•	48
		7.87	(200)	2031	(921)		•	48
		11.81	(300)	2738	(1242)		•	48
CR4400	5.0 (127,0)	3.0	(76,2)	201	(90)	•		50
CR4900	6.0 (152,4)	4.0	(101,6)	423	(192)	•		51
		6.0	(152,4)	719	(326)	•		51
		8.0	(203,2)	1052	(477)	•		51
		10.0	(254,0)	1395	(633)	•		51
		12.0	(304,8)	1733	(786)	•		51



SW038 Series

Specifications

Travel:	0.98 – 7.87 in (25 – 200 mm)
Size:	
Width	1.496 in (38,0 mm)
Length	2.13 – 9.02 in (54,1 – 229,1 mm)
Height	0.63 in (16,0 mm)
Load:	
Normal	213 – 789 lbs (97 – 358 kg)
Moment: Yaw, Pitch, Roll	See page 52
Straight line accuracy:	0.00008 in/in of travel 2 μm/25 mm of travel
Weight:	0.35 – 1.59 lbs (0,16 – 0,72 kg)
Construction:	Aluminum top; steel crossed roller bearings
Mounting surface:	Precision machined
Finish:	Anodize



Crossed Roller Slides

Dimensions in (mm)

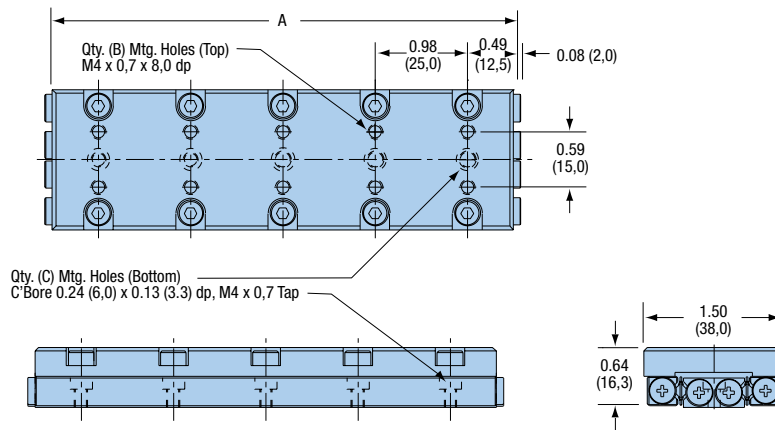

Model	Travel		Normal Load		Weight		Dimension A		Qty B	Qty C
	in	(mm)	lbs	(kg)	lbs	(kg)	in	(mm)		
SW038A-050	0.98	(25)	213	(97)	0.35	(0,16)	1.97	(50,0)	4	2
SW038A-075	1.97	(50)	263	(119)	0.52	(0,24)	2.95	(75,0)	6	3
SW038A-100	2.95	(75)	351	(159)	0.71	(0,32)	3.94	(100,0)	8	4
SW038A-125	3.94	(100)	439	(199)	0.88	(0,40)	4.92	(125,0)	10	5
SW038A-150	4.92	(125)	527	(239)	1.06	(0,48)	5.91	(150,0)	12	6
SW038A-175	5.91	(150)	684	(298)	1.24	(0,56)	6.89	(175,0)	14	7
SW038A-225	7.87	(200)	789	(358)	1.59	(0,72)	8.86	(225,0)	18	9

CR4000 Series

Specifications	
Travel:	1.0 in (25,4 mm)
Size:	
Width	1.75 in (44,5 mm)
Length	1.75 in (44,5 mm)
Height	1.00 in (25,4 mm)
Load:	
Normal	81 lbs (37 kg)
Moment: Yaw, Pitch, Roll	See page 53
Straight line accuracy:	0.00008 in/in of travel 2 µm/25 mm of travel
Weight:	0.2 lbs
Construction:	Aluminum top and base; steel crossed roller bearings
Mounting surface:	Precision machined
Finish:	Black anodize



Dimensions in (mm)

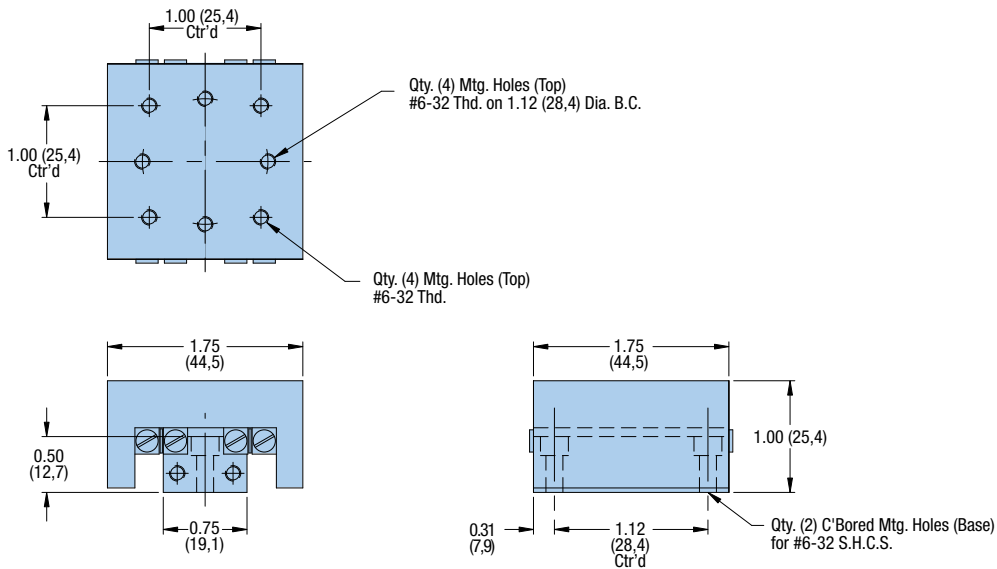

Model	Travel
CR4001	1.0 in (25,4 mm)



CR4100, CR4200, CR4300 Series

Specifications

Travel: 1.0 – 3.0 in
(25,4 – 76,2 mm)

Size:
Width 1.75 in (44,5 mm)
Length 2.00 – 4.00 in
Height 50,8 – 101,6 mm
 1.00 in (25,4 mm)

Load:
Normal 81 – 131 lbs
Moment: Yaw, Pitch, Roll See page 53

Straight line accuracy: 0.00008 in/in of travel
 2 µm/25 mm of travel

Weight: 0.2 – 0.6 lbs

Construction: Aluminum top and base;
 steel crossed roller bearings

Mounting surface: Precision machined

Finish: Black anodize



Crossed Roller Slides

Dimensions in (mm)

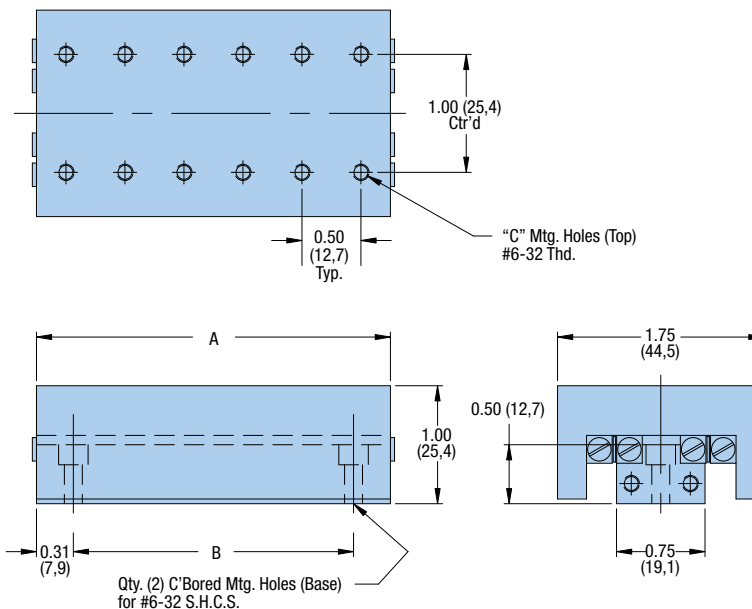

Model	Travel in (mm)	Normal Load lbs (kg)	Weight lbs (kg)	Dimensions – in (mm)		Qty C
				A	B	
CR4101	1.0 (25,4)	81 (37)	0.2 (0,09)	2.00 (50,8)	1.38 (35,1)	8
CR4201	2.0 (50,8)	121 (55)	0.4 (0,18)	3.00 (76,2)	2.38 (60,5)	12
CR4301	3.0 (76,2)	131 (59)	0.6 (0,27)	4.00 (101,4)	3.38 (85,9)	16

SE050 Series

Specifications	
Travel:	0.98 – 7.87 in (25 – 200 mm)
Size:	
Width	1.97 in (50,0 mm)
Length	2.13 – 9.02 in (54,1 – 229,1 mm)
Height	0.98 in (25,0 mm)
Load:	
Normal	175 – 789 lbs (80 – 358 kg)
Moment: Yaw, Pitch, Roll	See page 54
Straight line accuracy:	0.00008 in/in of travel 2 µm/25 mm of travel
Weight:	0.65 – 2.92 lbs (0,30 – 1,35 kg)
Construction:	Aluminum top and base; steel crossed roller bearings
Mounting surface:	Precision machined
Finish:	Black anodize



Dimensions in (mm)

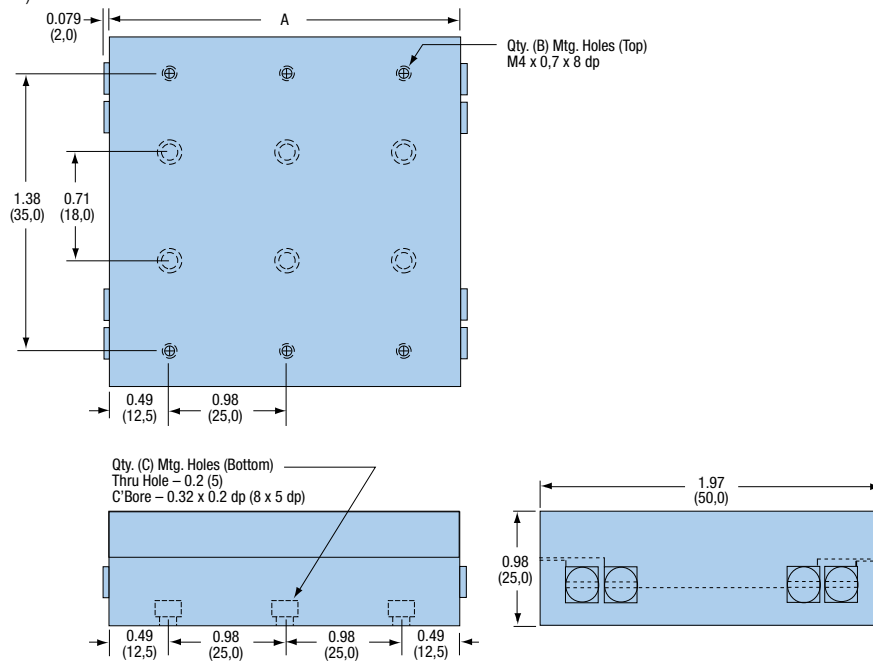

Model	Travel		Normal Load		Weight		Dimension A		Qty B	Qty C
	in	(mm)	lbs	(kg)	lbs	(kg)	in	(mm)		
SE050A-050	0.98	(25)	175	(80)	0.65	(0,30)	1.97	(50,0)	4	4
SE050A-075	1.97	(50)	263	(119)	0.97	(0,45)	2.95	(75,0)	6	6
SE050A-100	2.95	(75)	351	(159)	1.30	(0,60)	3.94	(100,0)	8	8
SE050A-125	3.94	(100)	439	(199)	1.62	(0,75)	4.92	(125,0)	10	8
SE050A-150	4.92	(125)	527	(239)	1.95	(0,90)	5.91	(150,0)	12	8
SE050A-175	5.91	(150)	614	(278)	2.21	(1,05)	6.89	(175,0)	14	8
SE050A-225	7.87	(200)	789	(358)	2.92	(1,35)	8.86	(225,0)	18	8



SP050 Series

Specifications

Travel:	0.98 – 2.95 in (25 – 75 mm)
Size:	
Width	1.97 in (50,0 mm)
Length	3.43 – 7.37 in (87,1 – 187,2 mm)
Height	0.98 in (25,0 mm)
Load:	
Normal	175 – 351 lbs (80 – 159 kg)
Moment: Yaw, Pitch, Roll	See page 55
Straight line accuracy:	0.00008 in/in of travel 2 µm/25 mm of travel
Weight:	0.86 – 2.00 lbs (0,39 – 0,91 kg)
Construction:	Aluminum top and base; steel crossed roller bearings
Mounting surface:	Precision machined
Finish:	Black anodize

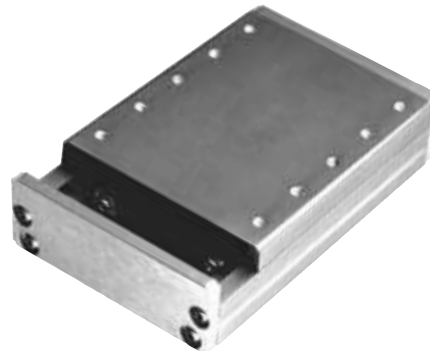

Crossed Roller Slides

Dimensions in (mm)

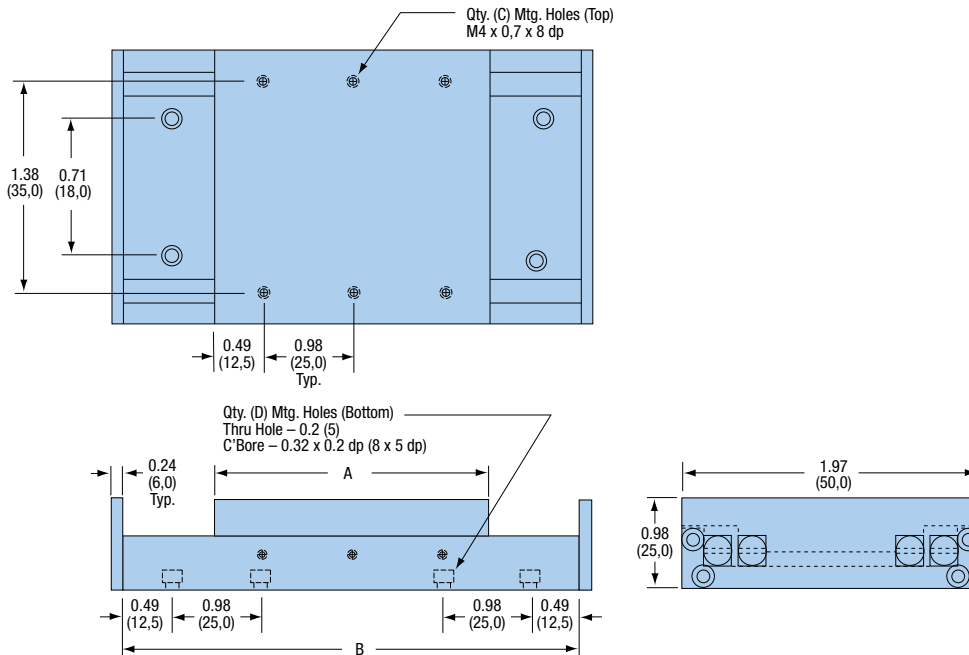

Model	Travel		Normal Load		Weight		Dimension A		Dimension B		Qty C	Qty D
	in	(mm)	lbs	kg	lbs	(kg)	in	(mm)	in	(mm)		
SP050A-075	0.98	(25)	175	(80)	0.86	(0,39)	1.97	(50,0)	2.95	(75,0)	4	6
SP050A-125	1.97	(50)	263	(119)	1.43	(0,65)	2.95	(75,0)	4.92	(125,0)	6	8
SP050A-175	2.95	(75)	351	(159)	2.00	(0,91)	3.94	(100,0)	6.89	(175,0)	8	8

CR4500 Series

Specifications	
Travel:	1.0 in (25,4)
Size:	
Width	2.62 in (66,5 mm)
Length	2.62 in (66,5 mm)
Height	1.00 in (25,4 mm)
Load:	
Normal	111 lbs (50 kg)
Moment: Yaw, Pitch, Roll	See page 53
Straight line accuracy:	0.00008 in/in of travel 2 µm/25 mm of travel
Weight:	CR4501 – 0.8 lbs (0,36 kg) CR4505 – 0.7 lbs (0,32 kg)
Construction:	Aluminum top and base; steel crossed roller bearings
Mounting surface:	Precision machined
Finish:	Black anodize



Dimensions in (mm)

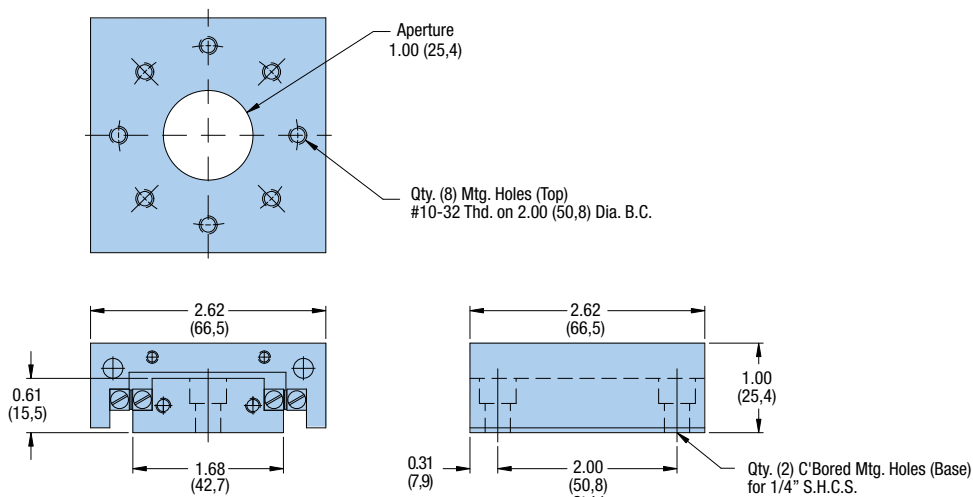

Model	Travel in (mm)	Aperture in (mm)
CR4501	1.0 (25,4)	—
CR4505	1.0 (25,4)	1.00 (25,4)



CR4600, CR4700, CR4800 Series

Specifications

Travel:	2.0 – 4.0 in (50,8 – 101,6 mm)
Size:	
Width	2.62 in (66,5 mm)
Length	4.00 – 6.00 in (101,6 – 152,4 mm)
Height	1.00 in (25,4)
Load:	
Normal	151 – 252 lbs (69 – 114 kg)
Moment: Yaw, Pitch, Roll	See page 53
Straight line accuracy:	0.00008 in/in of travel 2 µm/25 mm of travel
Weight:	0.9 – 1.4 lbs (0,4 – 0,6 kg)
Construction:	Aluminum top and base; steel crossed roller bearings
Mounting surface:	Precision machined
Finish:	Black anodize

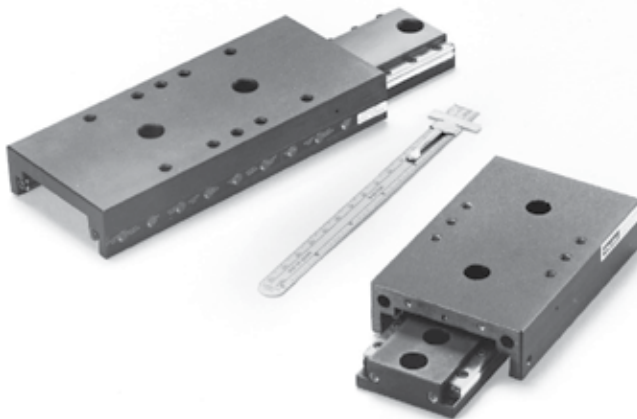

Crossed Roller Slides

Dimensions in (mm)

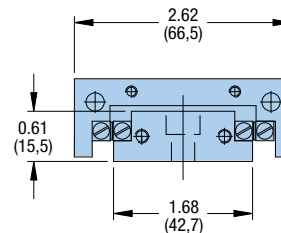
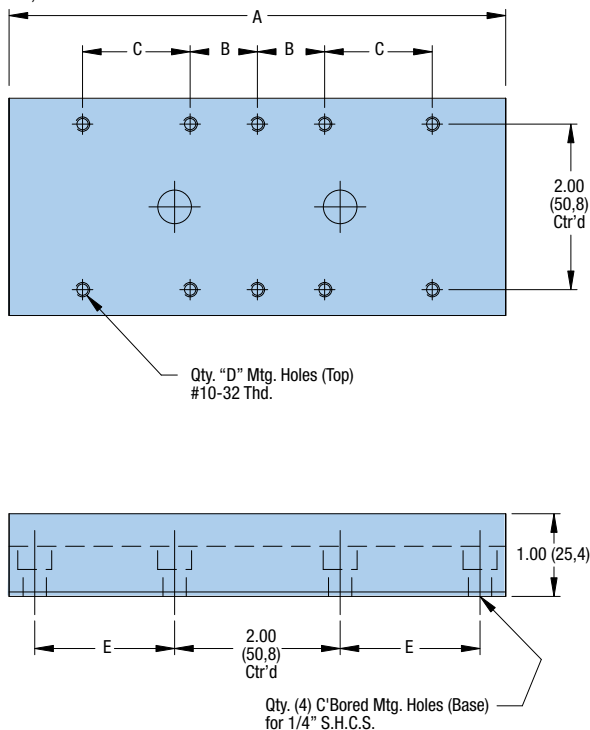

Model	Travel in (mm)	Normal Load lbs (kg)	Weight lbs (kg)	Dimensions — in (mm)				
				A	B	C	D	E
CR4601	2.0 (50,8)	151 (69)	0.9 (0,4)	4.00 (101,6)	0.5 (12,7)	—	6	0.69 (17,5)
CR4701	3.0 (76,2)	201 (91)	1.1 (0,5)	5.00 (127,0)	1.0 (25,4)	—	6	1.19 (30,2)
CR4801	4.0 (101,6)	252 (114)	1.4 (0,6)	6.00 (152,4)	0.5 (12,7)	1.0 (12,7)	10	1.69 (42,9)

SE075 Series

Specifications	
Travel:	1.97 – 7.87 in (50 – 200 mm)
Size:	
Width	2.95 in (75,0 mm)
Length	3.11 – 9.02 in (79,0 – 229,1 mm)
Height	1.26 in (32,0 mm)
Load:	
Normal	263 – 789 lbs (119 – 358 kg)
Moment: Yaw, Pitch, Roll	See page 56
Straight line accuracy:	0.00008 in/in of travel 2 μm/25 mm of travel
Weight:	1.50 – 4.52 lbs (0,69 – 2,07 kg)
Construction:	Aluminum top and base; steel crossed roller bearings
Mounting surface:	Precision machined
Finish:	Black anodize



Dimensions

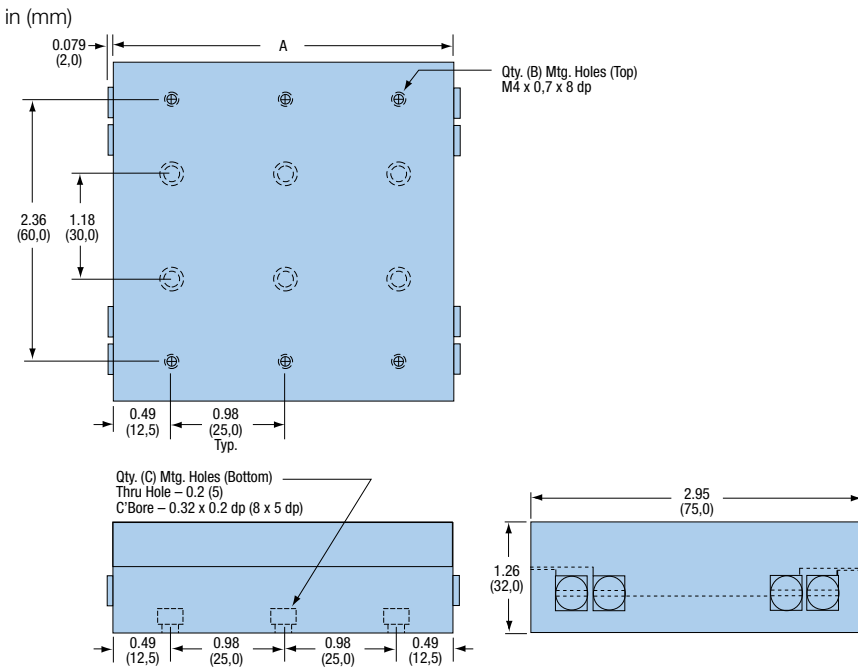

Model	Travel		Normal Load		Weight		Dimension A		Qty B	Qty C
	in	(mm)	lbs	(kg)	lbs	(kg)	in	(mm)		
SE075A-075	1.97	(50)	263	(119)	1.50	(0,69)	2.95	(75,0)	6	6
SE075A-100	2.95	(75)	351	(159)	2.01	(0,92)	3.94	(100,0)	8	8
SE075A-125	3.94	(100)	439	(199)	2.51	(1,15)	4.92	(125,0)	10	8
SE075A-150	4.92	(125)	527	(239)	3.01	(1,38)	5.91	(150,0)	12	8
SE075A-175	5.91	(150)	614	(278)	3.51	(1,61)	6.89	(175,0)	14	8
SE075A-225	7.87	(200)	789	(358)	4.52	(2,07)	8.86	(225,0)	18	8



SP075 Series

Specifications

Travel:	0.98 – 2.95 in (25 – 75 mm)
Size:	
Width	2.95 in (75,0 mm)
Length	4.42 – 8,35 in (112,3 – 212,1 mm)
Height	1.26 in (32,0 mm)
Load:	
Normal	348 – 439 lbs (158 – 199 kg)
Moment: Yaw, Pitch, Roll	See page 57
Straight line accuracy:	0.00008 in/in of travel 2 µm/25 mm of travel
Weight:	1.54 – 3.07 lbs (0,72 – 1,44 kg)
Construction:	Aluminum top and base; steel crossed roller bearings
Mounting surface:	Precision machined
Finish:	Black anodize



Crossed Roller Slides

Dimensions in (mm)

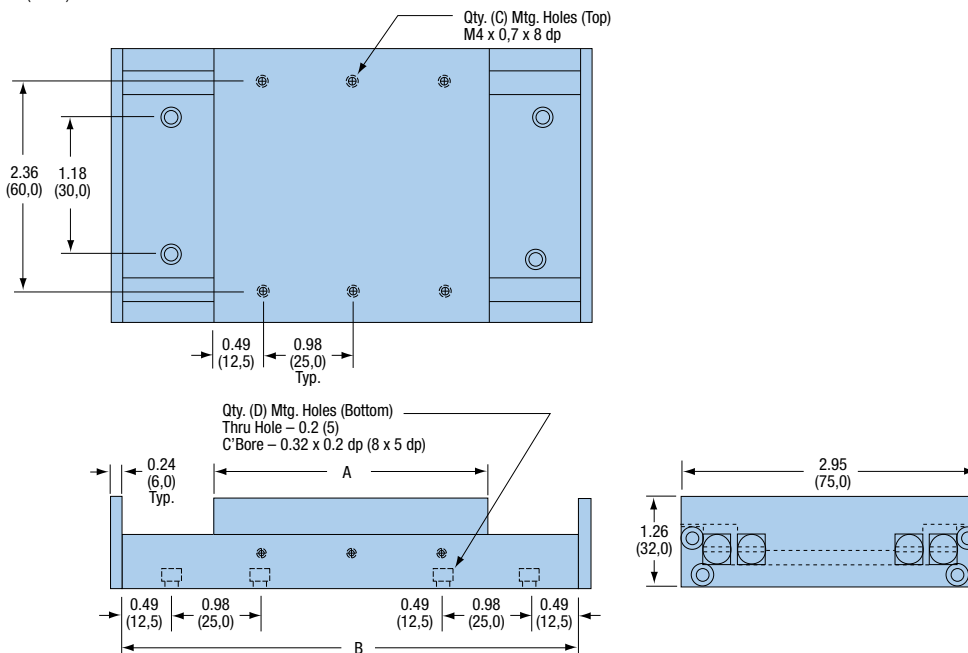

Model	Travel		Normal Load		Weight		Dimension A		Dimension B		Qty C	Qty D
	in	(mm)	lbs	(kg)	lbs	(kg)	in	(mm)	in	(mm)		
SP075A-150	1.97	(50)	348	(158)	2.30	(1,08)	3.94	(100,0)	5.91	(150,0)	8	8
SP075A-200	2.95	(75)	439	(199)	3.07	(1,44)	4.92	(125,0)	7.87	(200,0)	10	8

SE100 Series

Specifications	
Travel:	2.95 – 11.81 in (75 – 300 mm)
Size:	
Width	3.94 in (100,0 mm)
Length	4.10 – 13.94 in (104,1 – 354,1 mm)
Height	1.46 in (37,0 mm)
Load:	
Normal	795 – 2758 lbs (631 – 1242 kg)
Moment: Yaw, Pitch, Roll	See page 58
Straight line accuracy:	0.00008 in/in of travel 2 µm/25 mm of travel
Weight:	3.08 – 13.64 lbs (1,4 – 6,3 kg)
Construction:	Aluminum top and base; steel crossed roller bearings
Mounting surface:	Precision machined
Finish:	Black anodize



Dimensions in (mm)

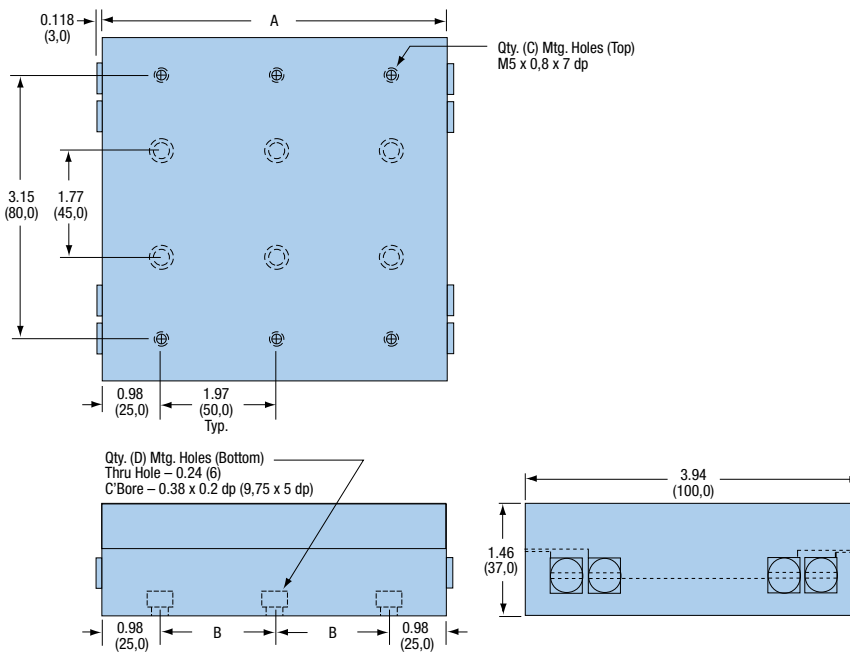

Model	Travel		Normal Load		Weight		Dimension A		Dimension B		Qty C	Qty D
	in	(mm)	lbs	(kg)	lbs	(kg)	in	(mm)	in	(mm)		
SE100A-100	2.95	(75)	795	(361)	3.08	(1,4)	3.94	(100,0)	1.97	(50,0)	4	4
SE100A-150	4.92	(125)	1236	(561)	4.55	(2,1)	5.91	(150,0)	1.97	(50,0)	6	6
SE100A-250	7.87	(200)	2031	(921)	7.58	(3,5)	9.84	(250,0)	1.97	(50,0)	10	8
SE100A-350	11.81	(300)	2738	(1242)	10.61	(4,9)	13.78	(350,0)	3.94	(100,0)	14	8



SP100 Series

Specifications

Travel:	0.98 – 3.94 in (25 – 100 mm)
Size:	
Width	3.94 in (100,0 mm)
Length	6.39 – 12.29 in (162,3 – 312,2 mm)
Height	1.46 in (37,0 mm)
Load:	
Normal	439 – 702 lbs (149 – 318 kg)
Moment: Yaw, Pitch, Roll	See page 59
Straight line accuracy:	0.00008 in/in of travel 2 µm/25 mm of travel
Weight:	3.66 – 7.32 lbs (1,68 – 3,38 kg)
Construction:	Aluminum top and base; steel crossed roller bearings
Mounting surface:	Precision machined
Finish:	Black anodize



Crossed Roller Slides

Dimensions in (mm)

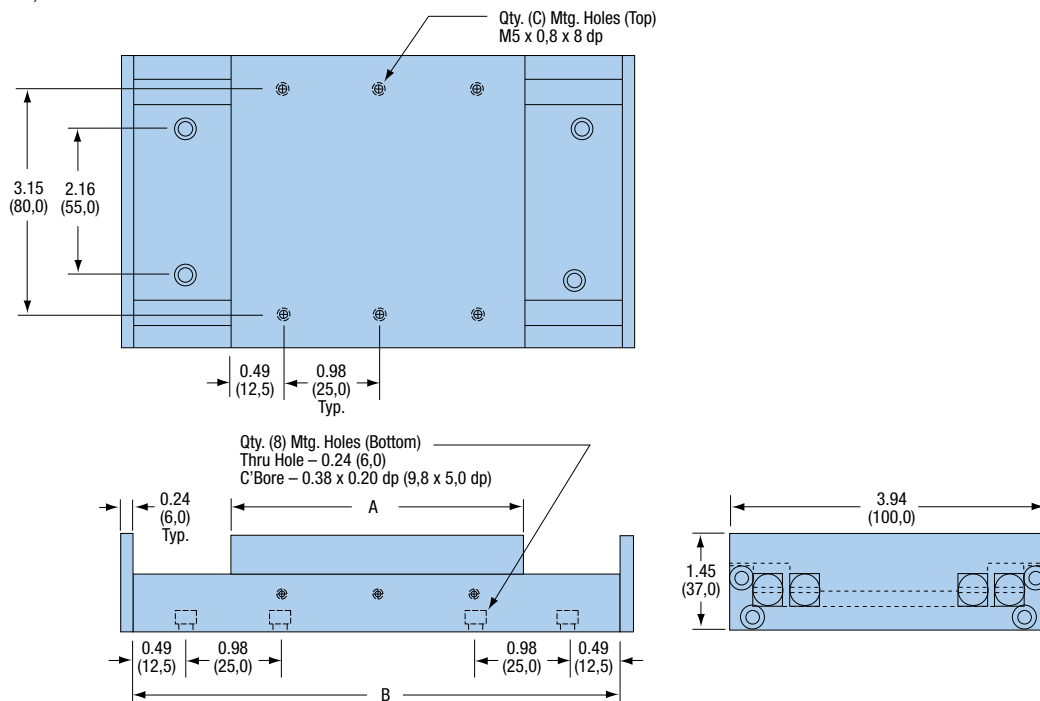

Model	Travel		Normal Load		Weight		Dimension A		Dimension B		Qty C
	in	(mm)	lbs	(kg)	lbs	(kg)	in	(mm)	in	(mm)	
SP100A-150	0.98	(25)	439	(199)	3.66	(1,68)	4.92	(125,0)	5.91	(150,0)	10
SP100A-200	1.97	(50)	527	(239)	4.88	(2,24)	5.91	(150,0)	7.87	(200,0)	12
SP100A-250	2.95	(75)	614	(278)	6.10	(2,80)	6.89	(175,0)	9.84	(250,0)	14
SP100A-300	3.94	(100)	702	(318)	7.32	(3,36)	7.87	(200,0)	11.81	(300,0)	16

CR4400 Series

Specifications	
Travel:	3.0 in (76,2 mm)
Size:	
Width	5.00 in (127,0 mm)
Length	5.00 in (127,0 mm)
Height	1.00 in (25,4 mm)
Load:	
Normal	201 lbs (90 kg)
Moment: Yaw, Pitch, Roll	See page 60
Straight line accuracy:	0.00008 in/in of travel 2 μm/25 mm of travel
Weight:	CR4410 – 2.2 lbs (1 kg) CR4450 – 1.7 lbs (0,8 kg)
Construction:	Aluminum top and base; steel crossed roller bearings
Mounting surface:	Precision machined
Finish:	Black anodize

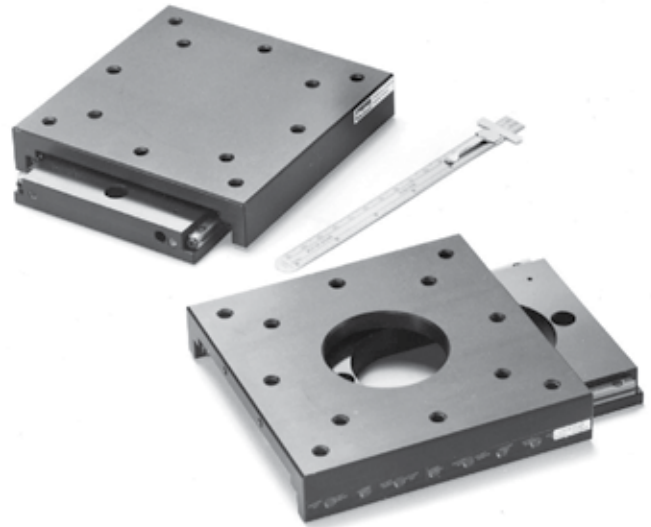

Dimensions in (mm)

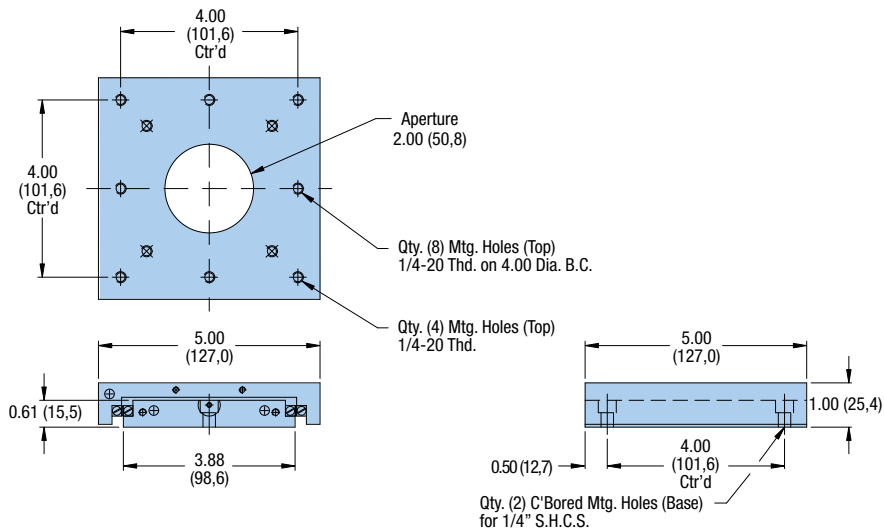

Model	Travel in (mm)	Aperture in (mm)
CR4410	3.0 (76,2)	—
CR4450	3.0 (76,2)	2.00 (50,8)



CR4900 Series

Specifications

Travel: 4.0 – 12.0 in (101,6 – 304,8 mm)

Size:

Width: 6.00 in (152,4 mm)
Length: 6.00 – 18.00 in (152,4 – 457,2 mm)
Height: 2.00 in

Load:

Normal: 423 – 1733 lbs (192 – 786 kg)
Moment: Yaw, Pitch, Roll: See page 60

Straight line accuracy: 0.00008 in/in of travel
 2 μm/25 mm of travel

Weight: 5.0 – 13.0 lbs (2,3 – 5,9 kg)

Construction: Aluminum top and base;
 steel crossed roller bearings

Mounting surface: Precision machined

Finish: Black anodize



Crossed Roller Slides

Dimensions in (mm)

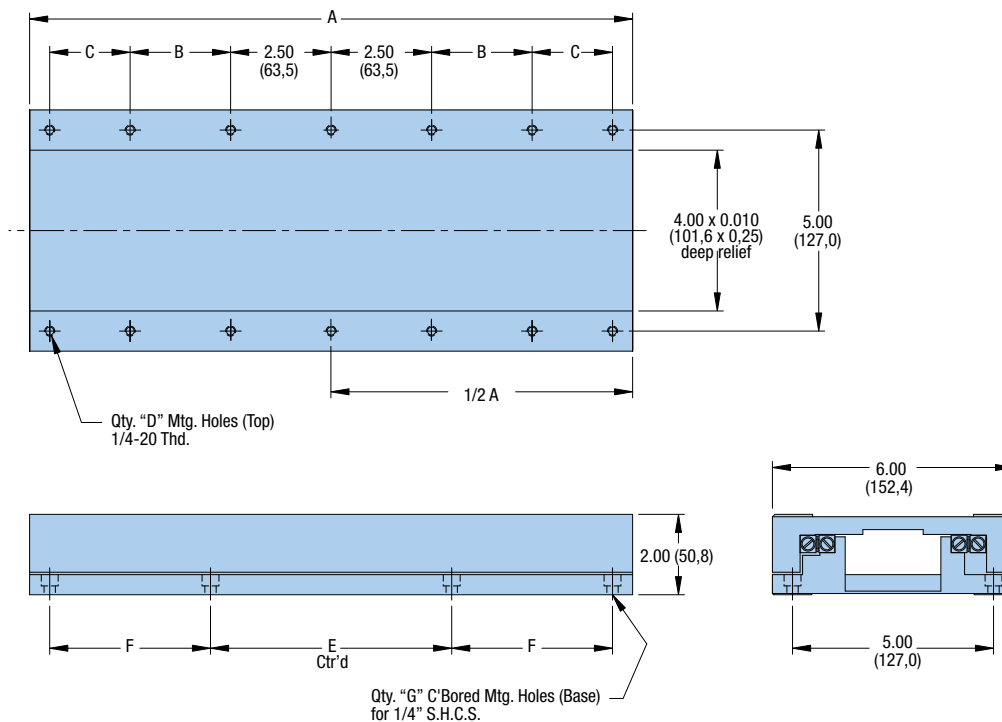

Model	Travel in (mm)	Normal Load lbs (kg)	Weight lbs (kg)	Dimensions — in (mm)						
				A	B	C	D	E	F	G
CR4900-04	4.0 in	423 (192)	5.0 (2,3)	6.00 (152,4)	—	—	6	5.00 (127,0)	—	4
CR4900-06	6.0 in	719 (326)	7.0 (3,2)	9.00 (228,6)	1.50 (38,1)	—	10	5.00 (127,0)	1.50 (38,1)	8
CR4900-08	8.0 in	1052 (477)	9.0 (4,1)	12.00 (304,8)	2.50 (63,5)	—	10	5.00 (127,0)	3.00 (76,2)	8
CR4900-10	10.0 in	1395 (633)	11.0 (5,0)	15.00 (381,0)	2.50 (63,5)	2.00 (50,8)	14	6.00 (152,4)	4.00 (101,6)	8
CR4900-12	12.0 in	1733 (786)	13.0 (5,9)	18.00 (457,2)	5.00 (127,0)	1.00 (25,4)	14	7.00 (177,8)	5.00 (127,0)	8

Yaw, Pitch, Roll

Yaw & Pitch ■ Roll ■

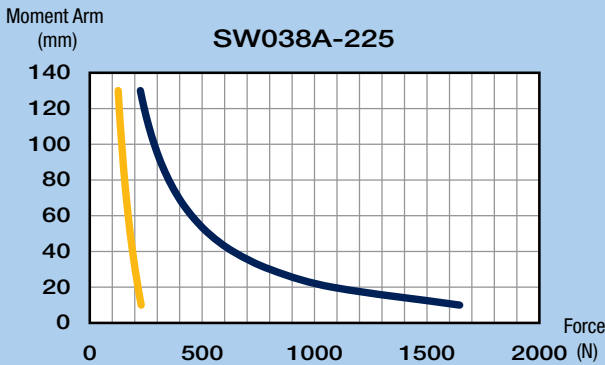
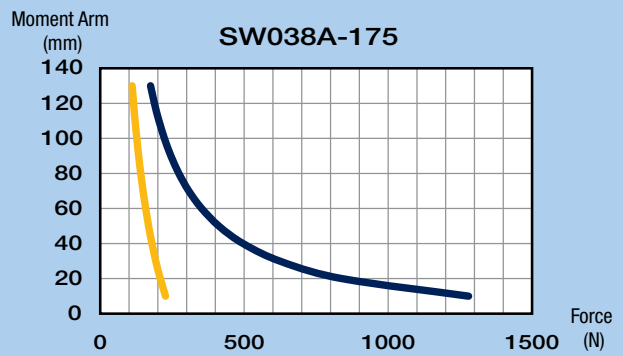
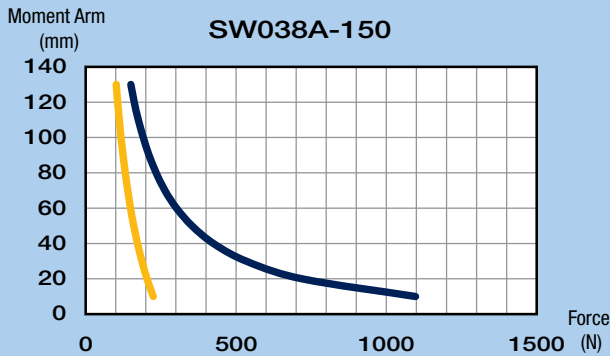
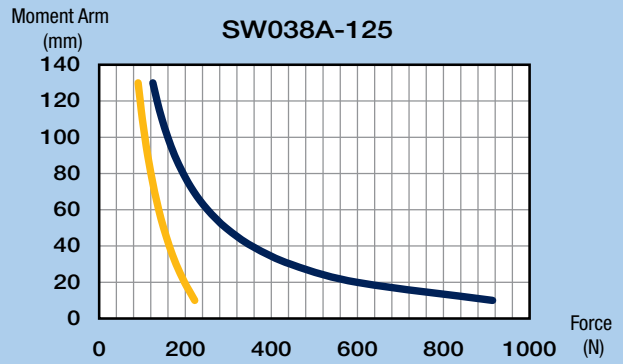
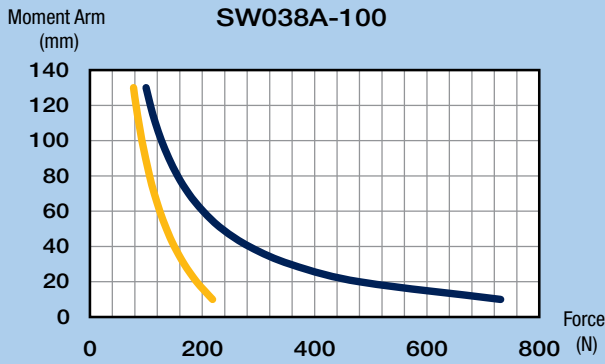
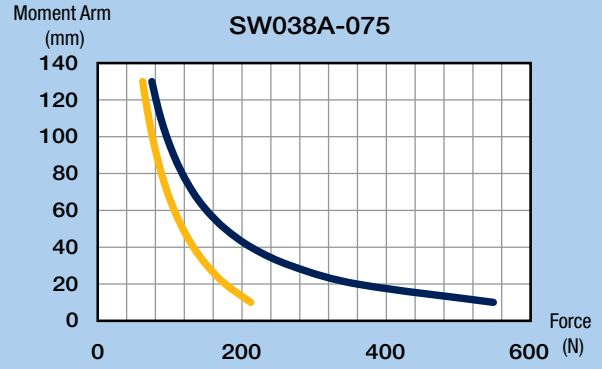
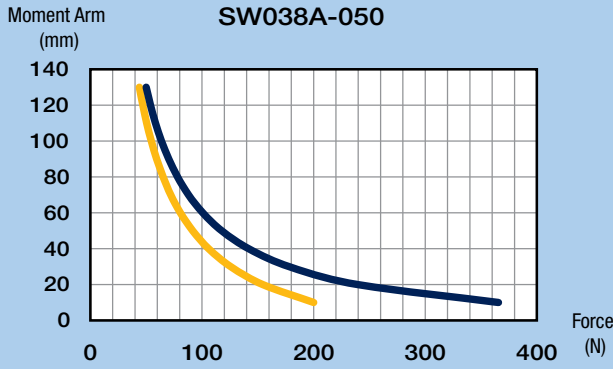

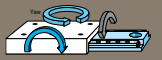

Yaw, Pitch, Roll

Yaw & Pitch Roll

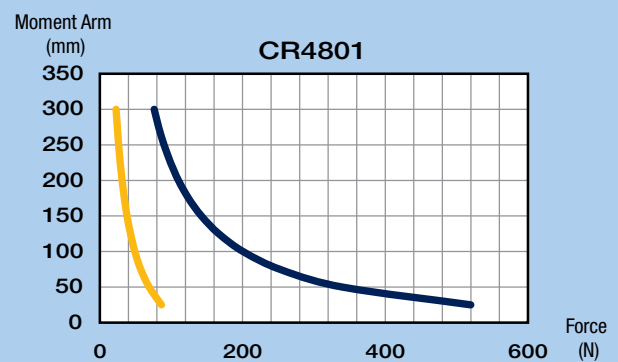
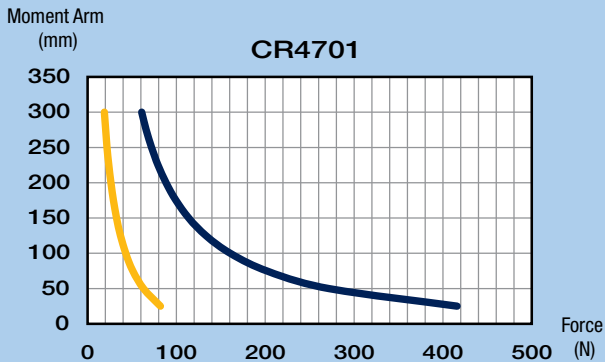
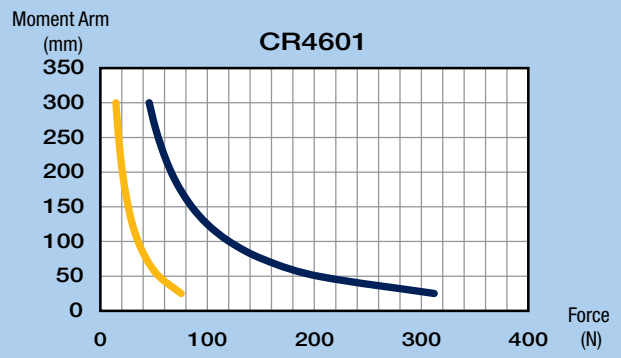
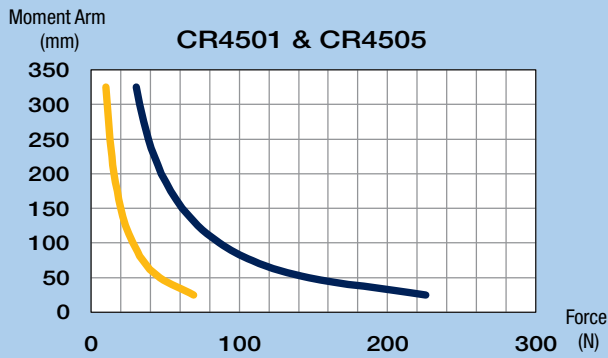
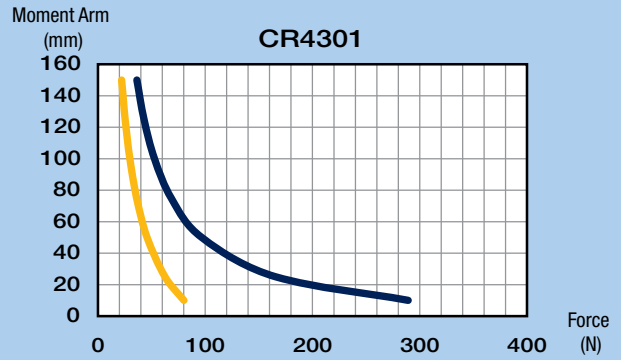
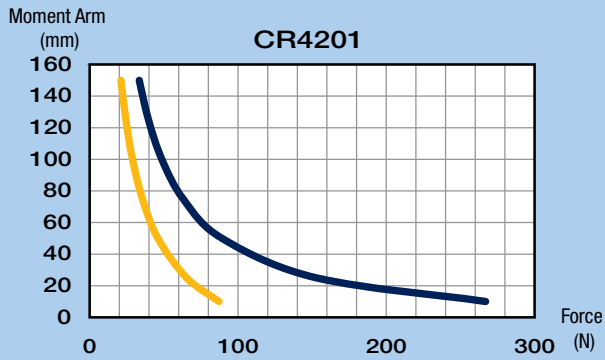
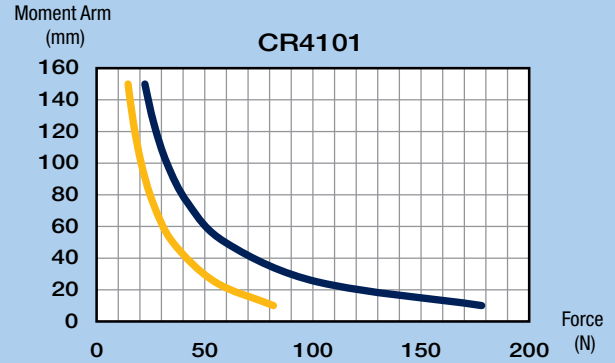
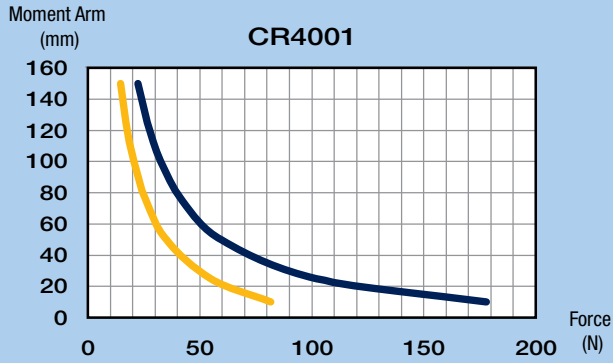

Yaw, Pitch, Roll

Yaw & Pitch Roll

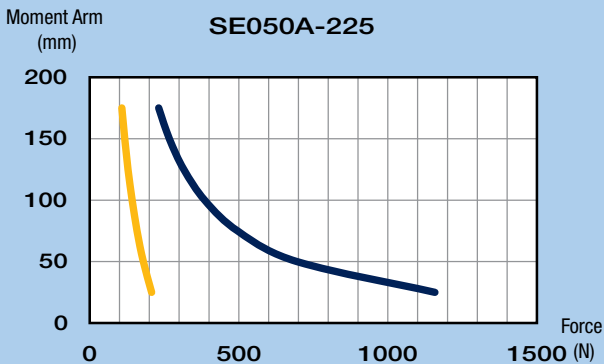
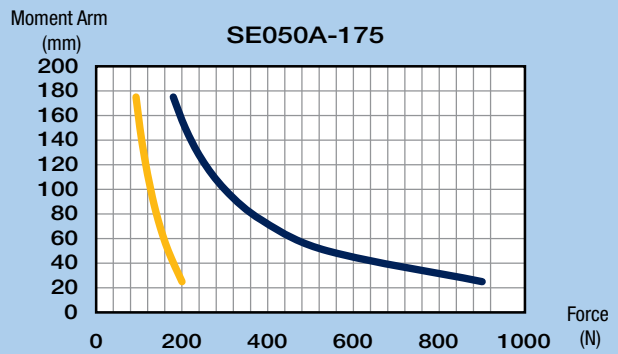
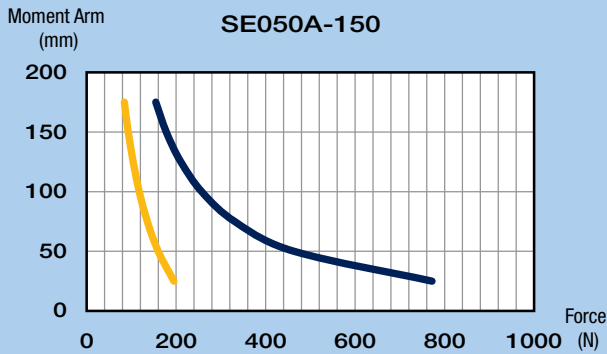
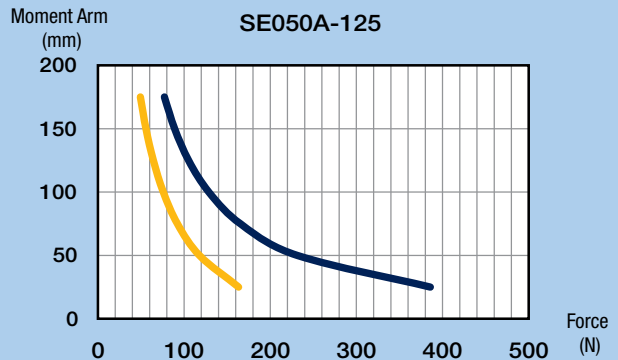
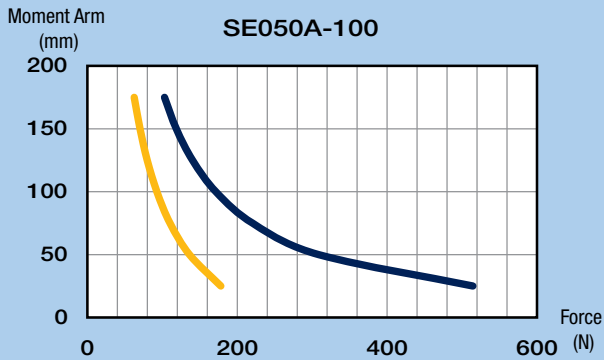
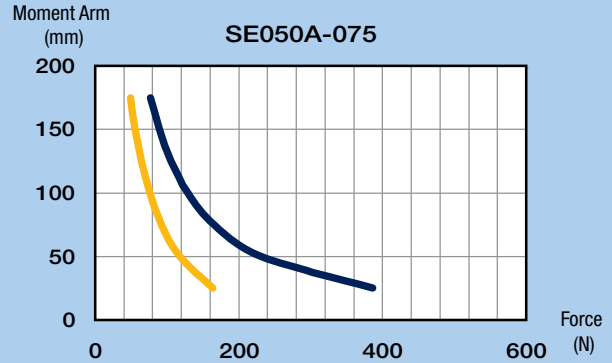
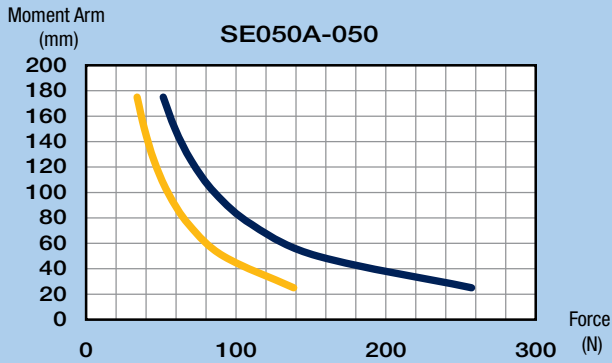

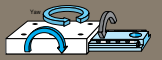

Yaw, Pitch, Roll

Yaw & Pitch **Roll**

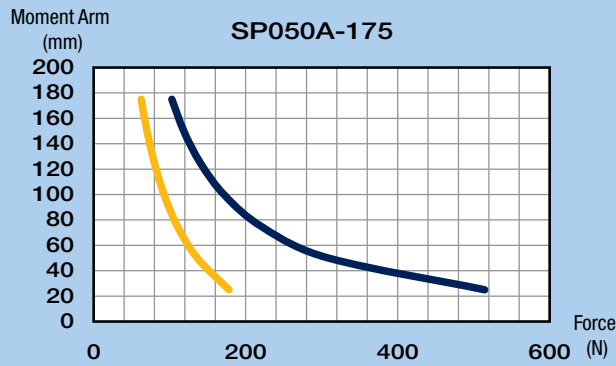
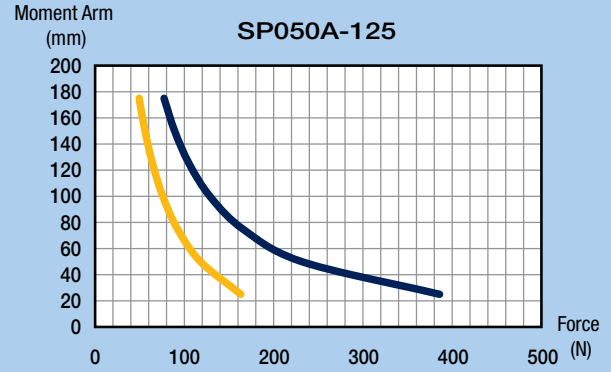
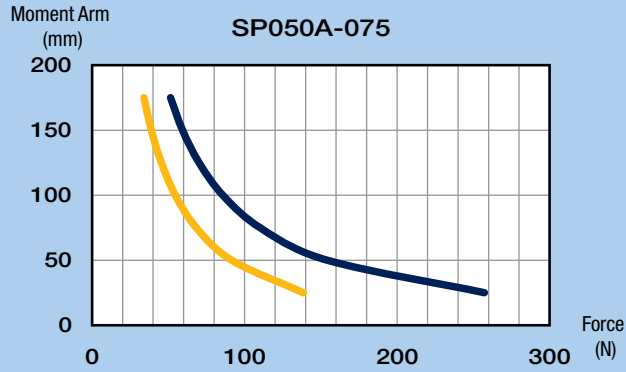

Yaw, Pitch, Roll

Yaw & Pitch Roll

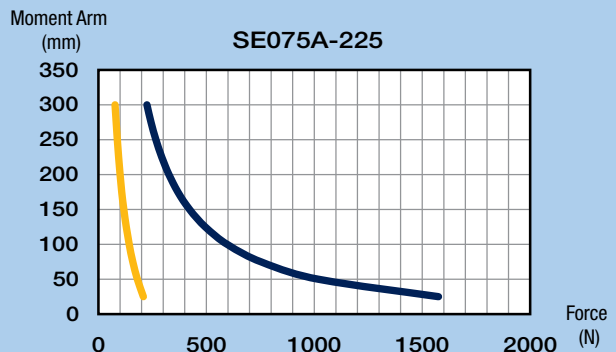
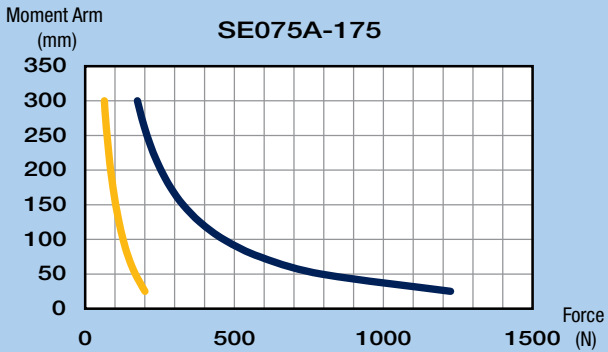
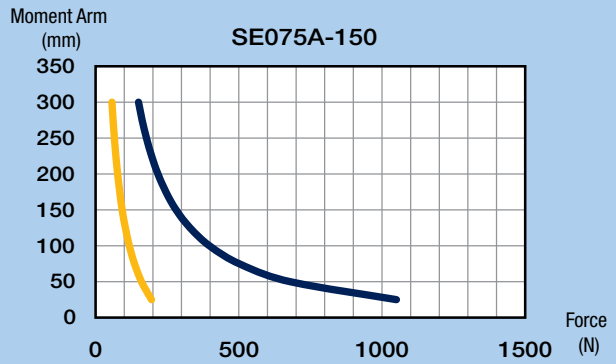
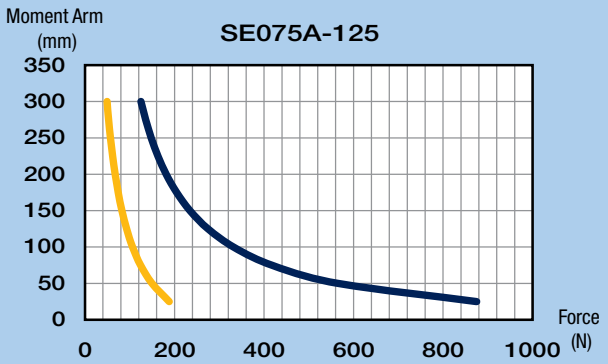
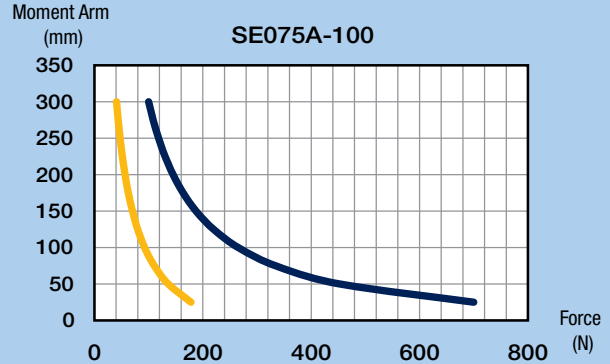
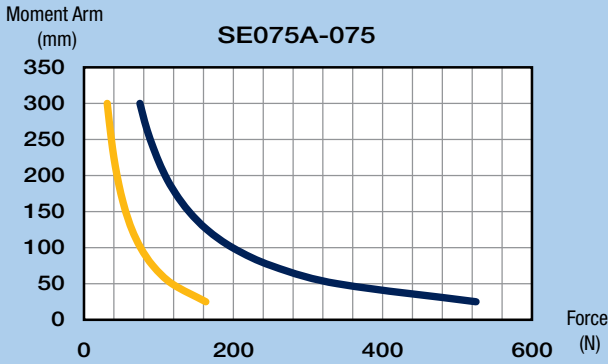

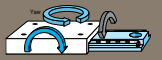

Crossed Roller Slides

Yaw, Pitch, Roll

Yaw & Pitch **Roll**

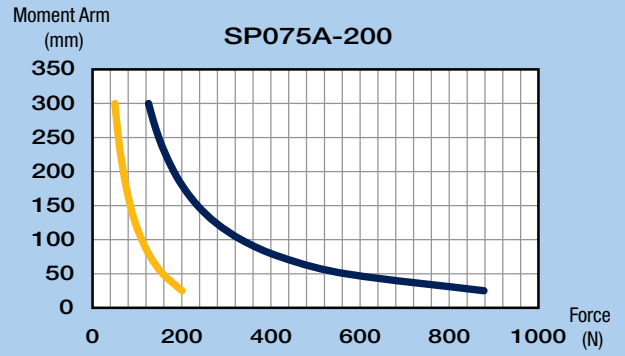
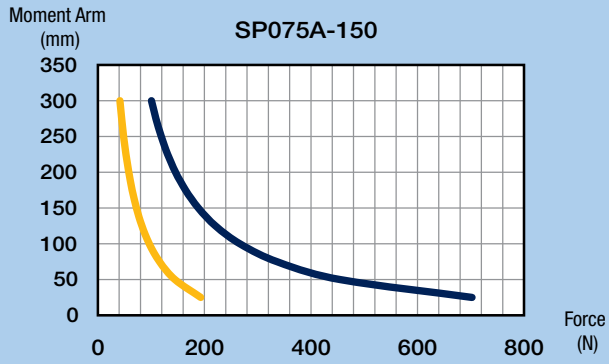

Yaw, Pitch, Roll

Yaw & Pitch Roll

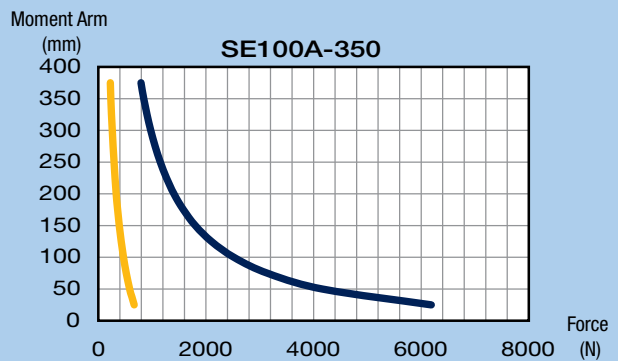
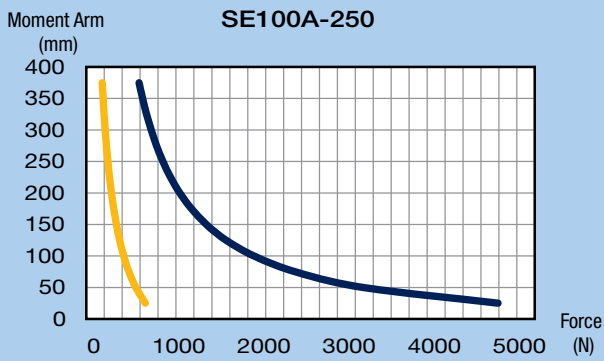
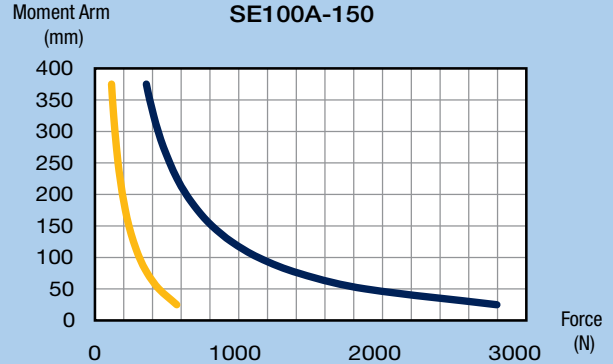
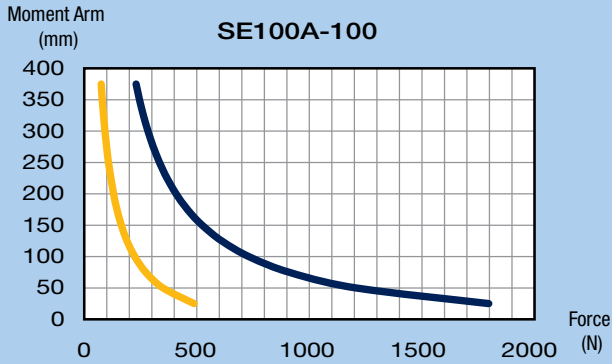

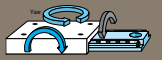

Yaw, Pitch, Roll

Yaw & Pitch Roll

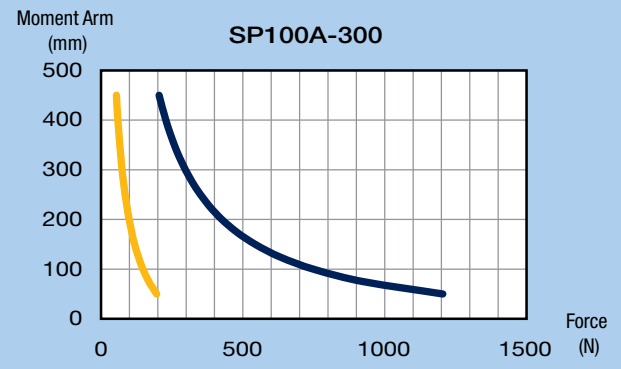
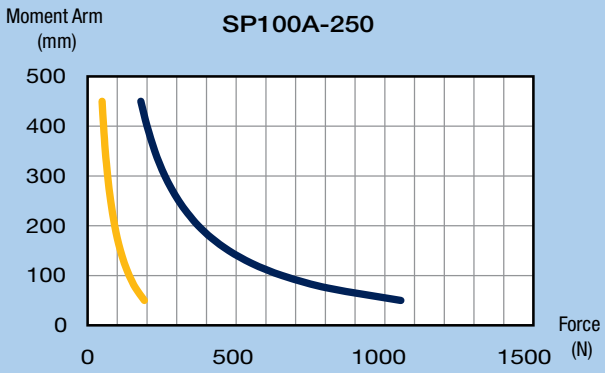
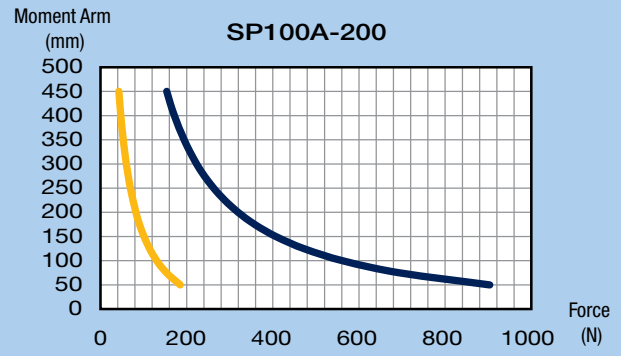
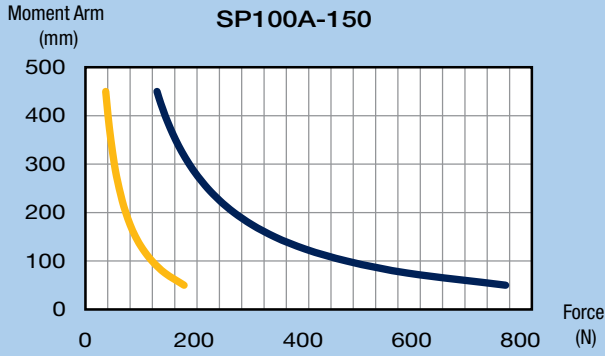

Yaw, Pitch, Roll

Yaw & Pitch Roll

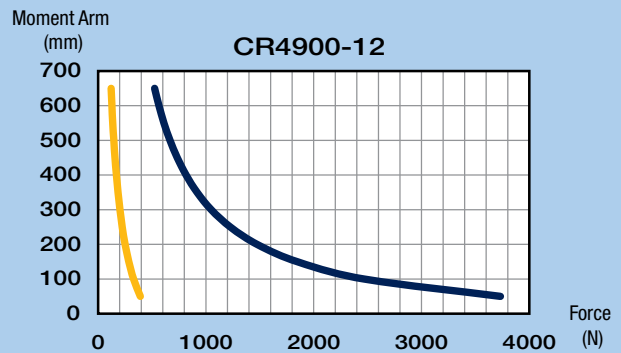
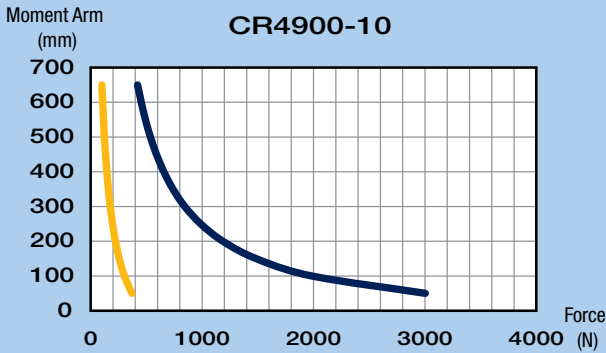
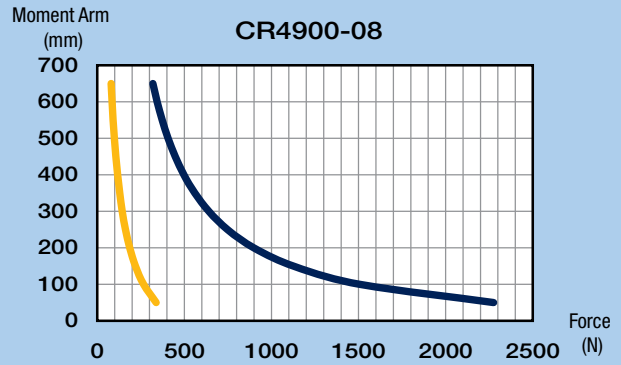
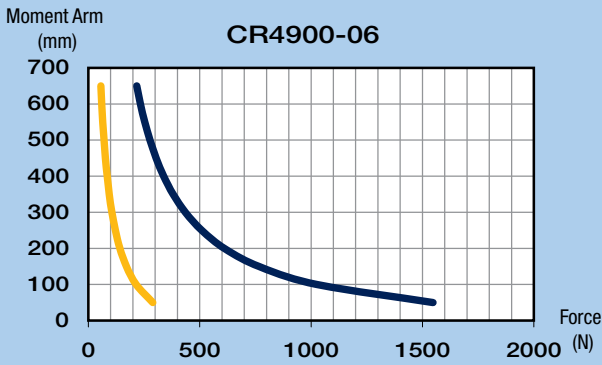
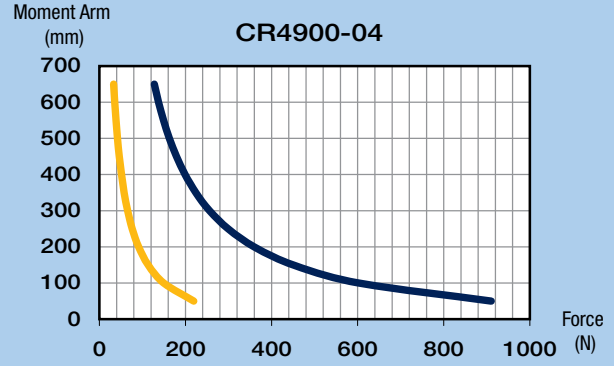
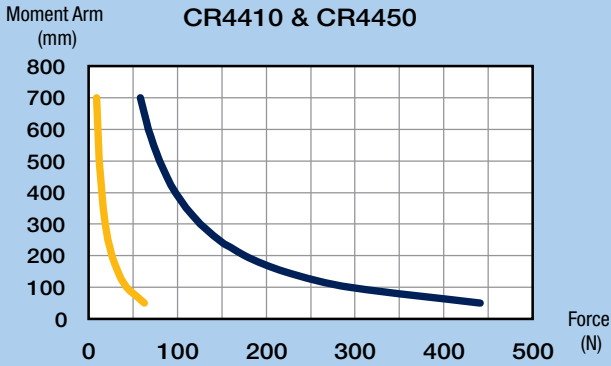

Ball Bearing Positioners

Miniature and Standard

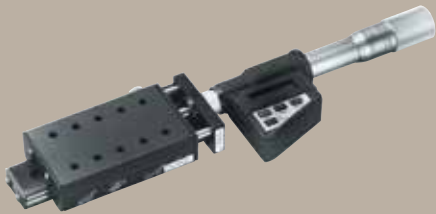
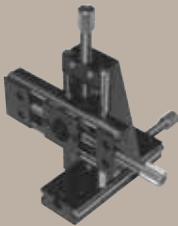

Parker precision linear stages provide controlled, precise point-to-point positioning along a linear axis. Stages are comprised of two basic components: a precision linear ball slide which serves as a linear bearing and guide, and a drive mechanism which accurately moves and positions the slide top along the linear axis.

Contents

62-63	Overview
64-67	1.25" (31,8 mm) Wide or Less
68-73	1.75" (44,5 mm) Wide
74-79	2.62" (66,5 mm) Wide
80-83	5.00" (127,0 mm) Wide
84-86	6.00" (152,4 mm) Wide
87-88	Performance Curves

Miniature and Standard Size Ball Bearings Positioners



- Precision Quality
- Budget Friendly
- Largest Selection
- Easy multi-axis configuration
- No maintenance
- Vacuum preparation and custom options

Ball Bearing Positioner Design Principles

Parker precision linear stages provide controlled, precise point-to-point positioning along a linear axis. Stages are comprised of two basic components: a precision linear ball slide which serves as a linear bearing and guide, and a drive mechanism which accurately moves and positions the slide top along the linear axis.

Three types of drive mechanisms are available: a fine screw, a micrometer, and a differential screw. The fine screw is used for fine resolution positioning. The micrometer is used whenever a position readout is required. The differential screw is used for applications requiring extremely fine resolution positioning. Ball bearing positioning stages are available in a straight stage/drive configuration as well as a side-drive configuration.

The linear positioner operates in a simple manner: a bracket which supports the drive screw is attached to the slide base. The end of the drive screw rests against the end of the moveable top. There are two extended springs “pulling” the slide top toward the screw so that the top will always be held firmly against the screw end. When the screw is turned clockwise, it advances and pushes the slide top along the linear axis. When turned counter clockwise, the screw retracts and the slide top follows because of the spring pressure holding the top against the screw end. The result is a very smooth linear motion, accurately controlled by rotation of the drive mechanism.

Standard Features

Exact manufacturing techniques combined with demanding quality control standards permit Parker Daedal to offer precision stages of unsurpassed quality. Selection can be made easily, based on required travel, load, and mounting surface requirements. Stages are available in single or multi-axis configurations (XY, XZ, and XYZ), and all have built-in quality features including:

- Aluminum top and base and stainless steel bearings
- Low friction linear adjustment with no backlash or side play
- Factory preloaded to provide dynamic stability and minimum runout
- Both top and bottom mounting surfaces are precision machined to provide flat mounting surfaces
- Locking screw to positively lock stage without affecting position (standard on most models)
- Straight line accuracy of 0.00008 in/in of travel
- Selectable drive mechanisms: Micrometer (Imperial or metric), Fine screw (64 pitch), Differential screw, Digital micrometers (Imperial and Metric)

Digital Micrometers

The 1.0” (25 mm) travel micrometer provides an LCD readout to 0.00005 in (0,001 mm) resolution and features incremental and/or absolute positioning modes and automatic shutdown to conserve the integral battery. The battery will power the unit for 500 hours of use. The 2.0” (51 mm) micrometer is accurate to ± 0.0001 in (± 2 microns) with a resolution and LCD reading to 0.00005 in (1 micron). The batteries will power the unit up to 500 hours.

How to Order

Use the overview chart on the following page to select the appropriate ball bearing positioner. Refer to the individual specifications page for complete performance and mechanical specifications. To order ball bearing positioners, use the model number corresponding to the specific size and travel length selected. A variety of modifications to standard models are available to meet custom requirements. Contact our application engineering department with your design specifications.

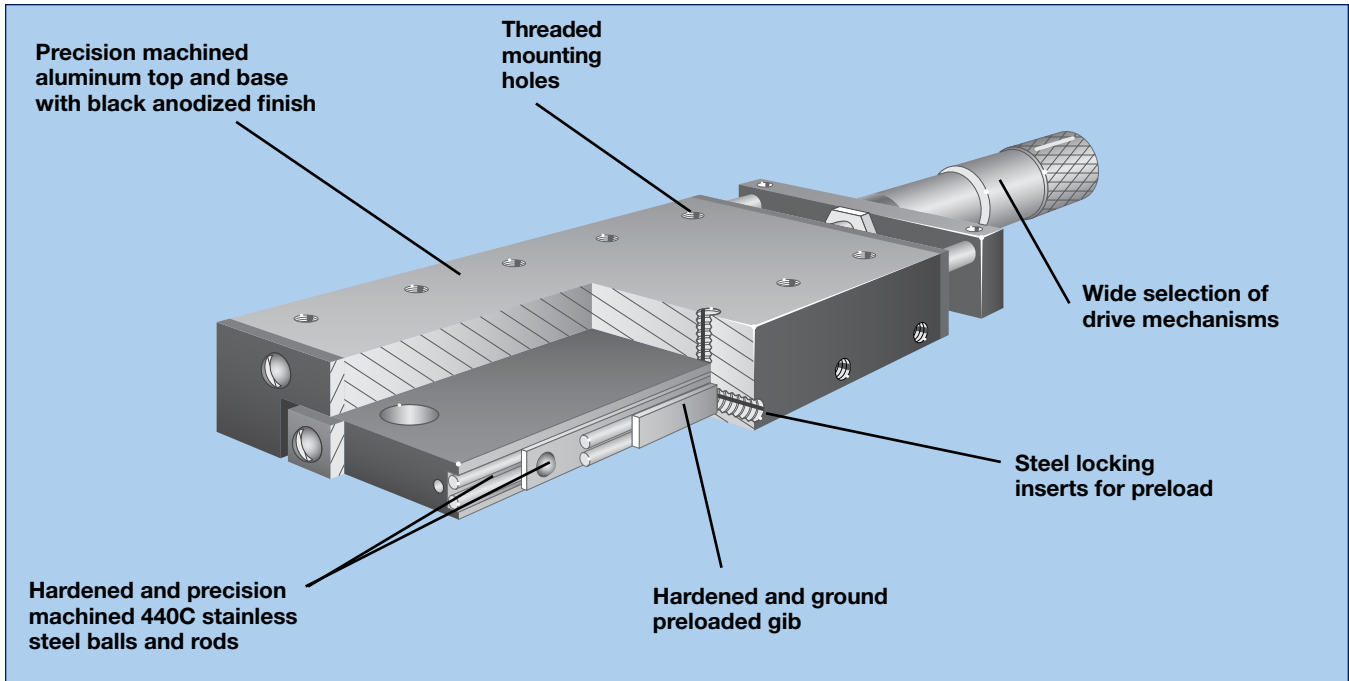

Selection

Series	Width in (mm)	Travel		Normal Load		Drive Orientation		Mounting		Page
		in	(mm)	lbs	(kg)	Center	Side	Imperial	Metric	
MM-1	≤1.25 (≤31,8)	0.125	(3,2)	0.5	(0,25)	•		•		64-65
MM-3		0.50	(12,7)	0.75	(0,34)	•		•		64-65
3900					6	(2,7)	•	•	•	•
4000	1.75 (44,5)	0.50 or	(12,7 or	25	(11)	•	•	•	•	68-69,72
4100		1.00	25,4)	30	(13)	•		•	•	70-71, 73
4200				42	(19)	•		•	•	70-71, 73
4300				55	(25)	•		•	•	70-71, 73
4500	2.62 (66,5)	1.00	(25,4)	62	(28)	•	•	•	•	74-75, 78
4600				88	(40)	•		•	•	76-77, 79
4700				106	(48)	•		•	•	76-77, 79
4800				123	(56)	•		•	•	76-77, 79
4400	5.0 (127,0)	1.0	(25,4)	105	(48)	•	•	•	•	80-83
		2.0	(50,8)	105	(48)	•	•	•	•	80-83
4900	6.0 (152,4)	1.0	(25,4)	100	(45)	•		•	•	84-85
		2.0	(50,8)	100	(45)	•		•	•	84-85
		4.0	(100,0)	100	(45)	•		•	•	86
		6.0	(150,0)	154	(70)	•		•	•	86
		8.0	(200,0)	205	(93)	•		•	•	86
		10.0	(250,0)	243	(110)	•		•	•	86
		12.0	(300,0)	294	(133)	•		•	•	86

MM-1 & MM-3 Series

Specifications	MM-1	MM-3
Travel:	0.125 in (3,175 mm)	0.5 in (12,7 mm)
Size:		
Width	0.44 in (11,2 mm)	0.66 in (16,8 mm)
Length (mid-travel)	1.405 in (35,7mm)	2.365 in (60,1 mm)
Height	0.20 in (5,1 mm)	0.28 in (7,1 mm)
Load:		
Normal	9 oz	12 oz
Moment:		
Yaw	1.5 in-oz	3.0 in-oz
Pitch	3.0 in-oz	6.0 in-oz
Roll	3.0 in-oz	6.0 in-oz
Straight line accuracy:	1 µm	1.5 µm
Maximum wobble:	0.01 mrad	0.01 mrad
Weight:	3 g/axis	16 g/axis
Construction:	Aluminum body, stainless steel rails	
Mounting surface:	Precision machined	
Finish:	Black anodize	

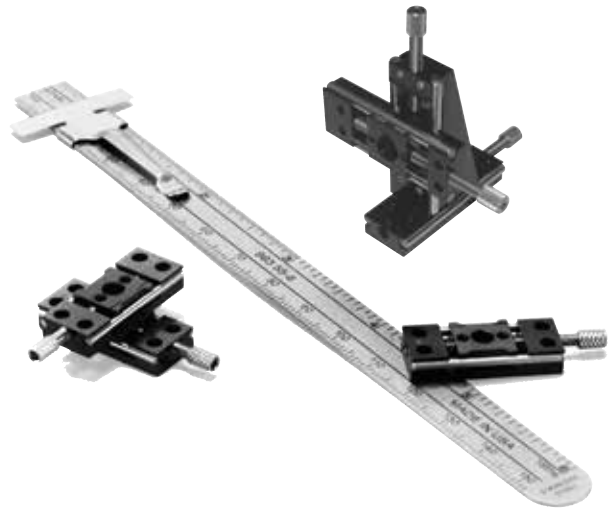

Parker precision miniature linear stages provide controlled, precise point-to-point positioning along a linear axis at a micron level of accuracy. Our smallest MM Series are driven along stainless steel rails by a fine 2-80 thread drive screw. Parker Daedal miniature positioning stages are a dimensional breakthrough in miniature positioning. The 0.125” travel MM-1 and 0.5” travel MM-3 are precision instruments designed to eliminate many research and design problems for space limited applications.

Applications

Applications include frequent or one-time fine adjustments, pinhole micrometer positioning (piggyback on a larger work stage), adjustable slit construction, fiber optics, R & D optical and electro-optical equipment, spatial filters, positioning probes and fine gas purges, turrents, individual positioning of elements, suspending ends of small gas lasers, and axial alignment of tubes and rods.

Features

- Black anodized aluminum body with stainless steel rails
- Precise, smooth motion
- Aperture accommodates pinhole adapters
- No backlash; positive spring-loaded carriage
- Fine 80 TPI screw adjustment with Allen socket
- Sturdy one-piece base, three-piece construction
- Includes ball driver
- Compact size:
 - MM-1 single stage is only 0.20” x 0.44” x 1.03” long;
 - MM-3 is 0.28” x 0.66” x 1.74” long
- Easily configured into X-Y setups without special adapters

Series	Model	Configurariion
	MM-1	Single axis
MM-1	MM-1 X-Y	Two axis
	MM-1 X-Y-Z	Three axis
	MM-3	Single axis
MM-1	MM-3 X-Y	Two axis
	MM-3 X-Y-Z	Three axis



Dimensions in (mm)

Ball Bearing Slides

MM-1

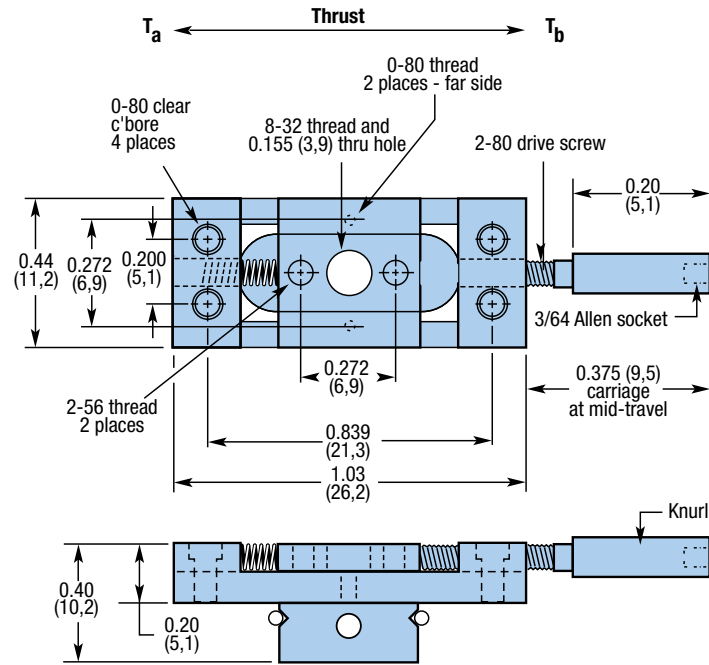

MM-3

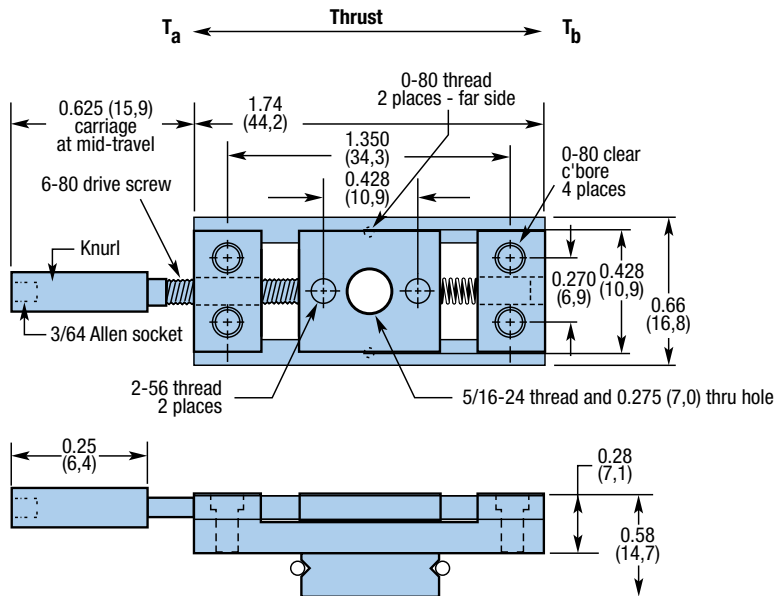

3900/M3900 Series

Specifications	Imperial	Metric
Travel:	0.5 in	13 mm
Size:		
Width	1.25 in	31,8 mm
Length (mid-travel)	3.34 in	84,8 mm
Height	0.50 in	12,7 mm
Load:		
Normal	6 lbs	3 kg
Thrust – T _a	10 lbs	4,5 kg
Thrust – T _b	3 lbs	1,4 kg
Moment – Yaw, Pitch, Roll	See page 88	See page 88
Straight line accuracy:	0.00008 in/in of travel	2 µm/25 mm of travel
Micrometer graduations:	0.001 in	0,01 mm
Fine screw:	64 pitch	64 pitch
Weight:	0.16 lbs/axis	0,078 kg/axis
Z-Axis bracket options: (See page 124-127)		
Center drive low profile	3909	M3909
Center drive standard	3910	M3910
Side drive low profile	3959	M3959
Side drive standard	3960	M3960
Construction:	Aluminum top and base/ 440C stainless steel bearings	
Mounting surface:	Precision machined	
Finish:	Black anodize	



	Style	Drive Mechanism	Travel	Center Drive Models				Side Drive Models			
				Single Axis	Two Axis	X-Y-Z Low Profile	X-Y-Z Standard	Single Axis	Two Axis	X-Y-Z Low Profile	X-Y-Z Standard
Imperial	Solid Top	Imperial Micrometer	0.50 in	3902	3922	3932	3942	3952	3972	3982	3992
		Metric Micrometer	13 mm	3902M	3922M	3932M	3942M	3952M	3972M	3982M	3992M
		Fine Screw	0.50 in	3903	3923	3933	3943	–	–	–	–
	Aperture (0.5 in)	Imperial Micrometer	0.50 in	3906	3926	3936	3946	3956	3976	3986	3996
		Metric Micrometer	13 mm	3906M	3926M	3936M	3946M	3956M	3976M	3986M	3996M
		Fine Screw	0.50 in	3907	3927	3937	3947	–	–	–	–
Metric	Solid Top	Metric Micrometer	13 mm	M3902M	M3922M	M3932M	M3942M	M3952M	M3972M	M3982M	M3992M
		Imperial Micrometer	0.50 in	M3902	M3922	M3932	M3942	M3952	M3972	M3982	M3992
		Fine Screw	12,7 mm	M3903	M3923	M3933	M3943	–	–	–	–
	Aperture (12,7 mm)	Metric Micrometer	13 mm	M3906M	M3926M	M3936M	M3946M	M3956M	M3976M	M3986M	M3996M
		Imperial Micrometer	0.50 in	M3906	M3926	M3936	M3946	M3956	M3976	M3986	M3996
		Fine Screw	12,7 mm	M3907	M3927	M3937	M3947	–	–	–	–



Dimensions in (mm)

For additional end view dimensions, refer to the 3900/M3900 ball slide drawing, page 20. Consult factory for critical dimension concerns.

Center Drive

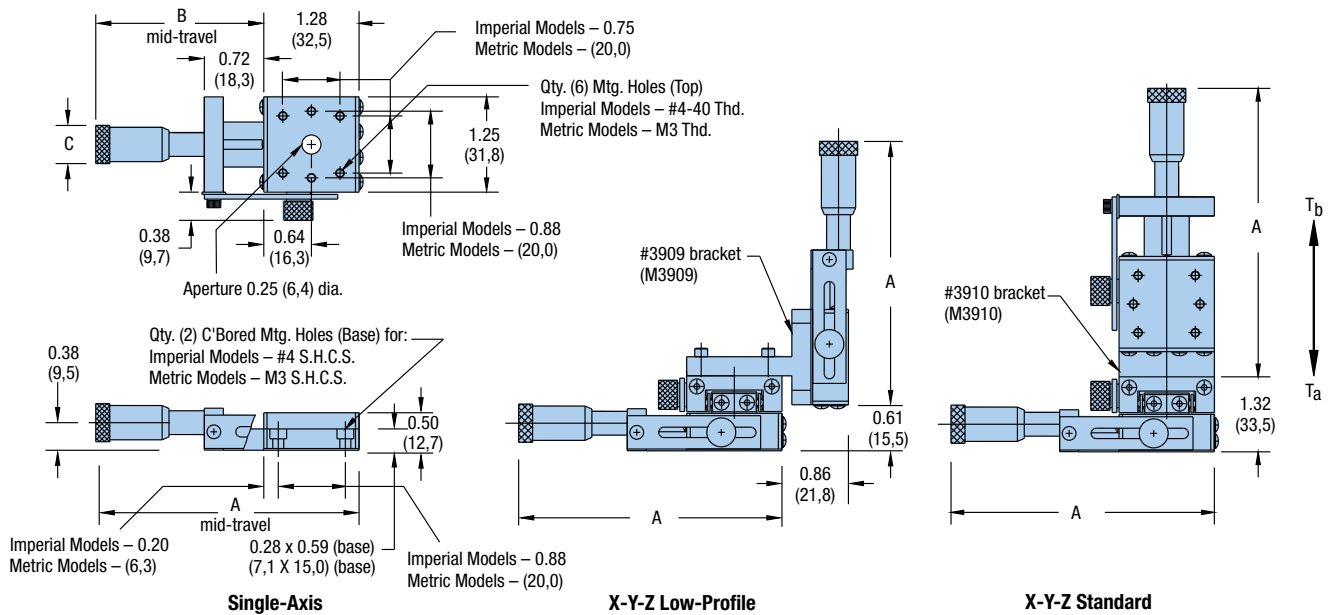

Style	Drive Mechanism	Travel	Imperial Model Dimensions – in			Metric Model Dimensions – mm		
			A	B	C	A	B	C
Solid Top	Imperial Micrometer	0.50 in	3.35	2.06	0.54	85,0	52,4	0.54
	Metric Micrometer	13 mm	3.35	2.06	0.54	85,0	52,4	0.54
	Fine Screw	0.50 in	2.32	1.03	0.58	58,3	25,9	0.58
Aperture	Imperial Micrometer	0.50 in	3.35	2.06	0.54	85,0	52,4	0.54
	Metric Micrometer	13 mm	3.35	2.06	0.54	85,0	52,4	0.54
	Fine Screw	0.50 in	2.32	1.03	0.58	58,3	25,9	0.58

Side Drive

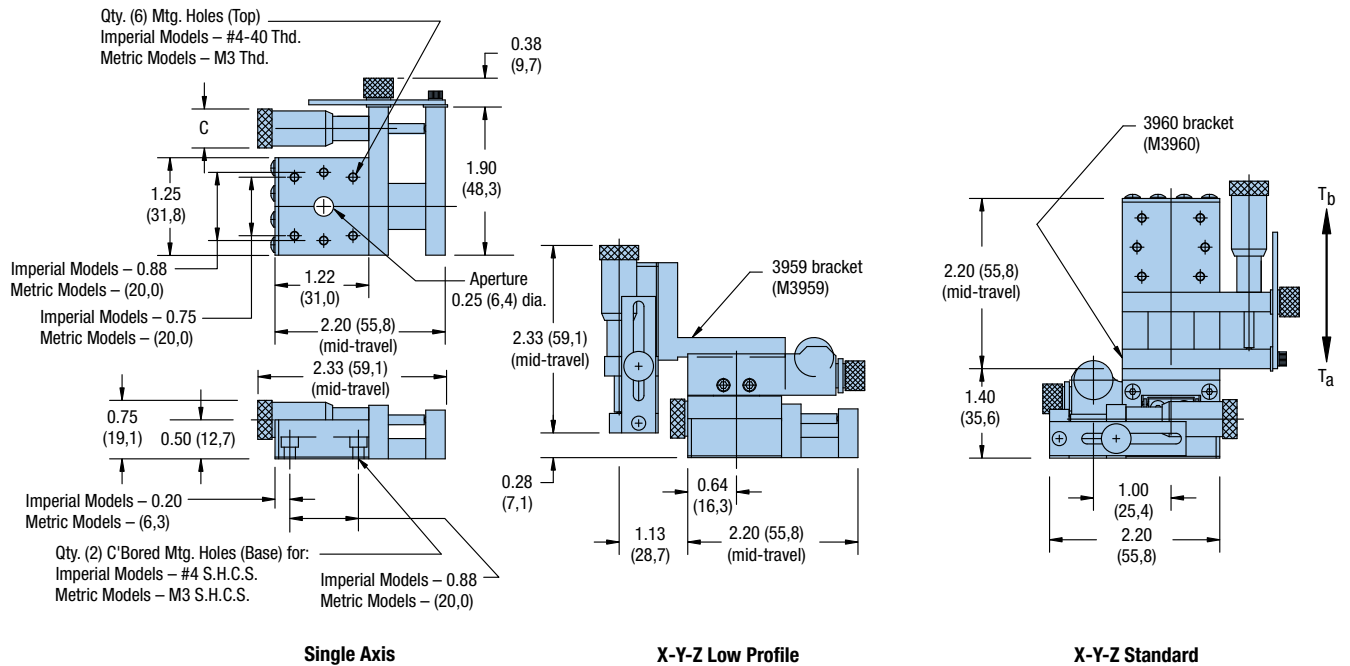

4000/M4000 Series

Specifications	Imperial	Metric
Travel:	0.5 – 1.0 in	12,7 – 25,4 mm
Size:		
Width	1.75 in	44,4 mm
Length (mid-travel)	2.63 – 6.03 in	68 – 153 mm
Height	0.75 in	19,0 mm
Load:		
Normal	25 lbs	11 kg
Thrust – T _a	10 lbs	4,5 kg
Thrust – T _b	5 lbs	2,3 kg
Moment – Yaw, Pitch, Roll	See page 87	See page 87
Straight line accuracy:	0.00008 in/in of travel	2 μm/25 mm of travel
Micrometer graduations:	0.001 in	0,01 mm
Differential screw:		
Coarse Adjustment	48 pitch	48 pitch
Fine Adjustment	336 pitch	336 pitch
Fine screw:	64 pitch	64 pitch
Weight:	0.5 lbs/axis	0,23 kg/axis
Z-Axis bracket options: (See page 124-127)		
Center drive low profile	4009	M4009
Center drive standard	4010	M4010
Side drive low profile	4059	M4059
Side drive standard	4060	M4060
Construction:	Aluminum top and base/ 440C stainless steel bearings	
Mounting surface:	Precision machined	
Finish:	Black anodize	



	Style	Drive Mechanism	Travel	Center Drive Models				Side Drive Models			
				Single Axis	Two Axis	X-Y-Z Low Profile	X-Y-Z Standard	Single Axis	Two Axis	X-Y-Z Low Profile	X-Y-Z Standard
Imperial	Solid Top	Imperial Micrometer	0.50 in	4002	4022	4032	4042	4052	4072	4082	4092
			1.0 in	4004	4024	4034	4044	4054	4074	4084	4094
		Metric Micrometer	13 mm	4002M	4022M	4032M	4042M	4052M	4072M	4082M	4092M
			25 mm	4004M	4024M	4034M	4044M	4054M	4074M	4084M	4094M
	Aperture (0.5 in)	Differential Screw	0.08/0.3 in	4002D	4022D	4032D	4042D	4052D	4072D	4082D	4092D
			Fine Screw	0.75 in	4003	4023	4033	4043	4053	4073	4083
		Imperial Micrometer	0.50 in	4006	4026	4036	4046	4056	4076	4086	4096
Metric Micrometer	13 mm		4006M	4026M	4036M	4046M	4056M	4076M	4086M	4096M	
Metric	Solid Top	Metric Micrometer	13 mm	M4002M	M4022M	M4032M	M4042M	M4052M	M4072M	M4082M	M4092M
			25 mm	M4004M	M4024M	M4034M	M4044M	M4054M	M4074M	M4084M	M4094M
		Imperial Micrometer	0.50 in	M4002	M4022	M4032	M4042	M4052	M4072	M4082	M4092
			1.0 in	M4004	M4024	M4034	M4044	M4054	M4074	M4084	M4094
	Differential Screw	2/8 mm	M4002D	M4022D	M4032D	M4042D	M4052D	M4072D	M4082D	M4092D	
		Fine Screw	19 mm	M4003	M4023	M4033	M4043	M4053	M4073	M4083	M4093
	Aperture (12,7 mm)	Metric Micrometer	13 mm	M4006M	M4026M	M4036M	M4046M	M4056M	M4076M	M4086M	M4096M
			Imperial Micrometer	0.50 in	M4006	M4026	M4036	M4046	M4056	M4076	M4086
		Differential Screw	2/8 mm	M4006D	M4026D	M4036D	M4046D	M4056D	M4076D	M4086D	M4096D
			Fine Screw	19 mm	M4007	M4027	M4037	M4047	M4057	M4077	M4087



Dimensions in (mm)

For additional end view dimensions, refer to the 4000/M4000 ball slide drawing, page 21. Consult factory for critical dimension concerns.

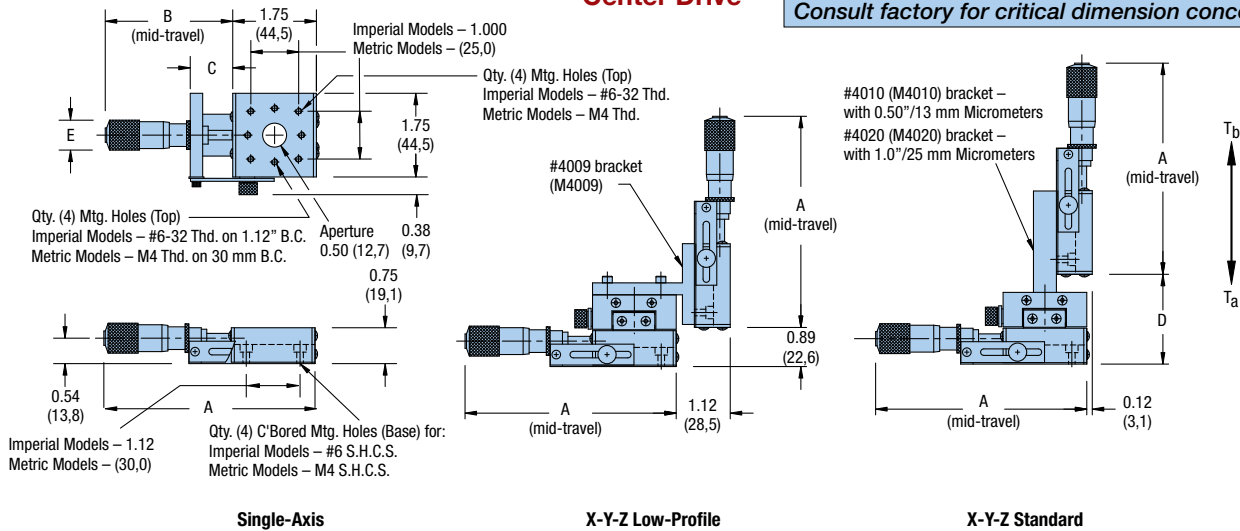

Side Drive

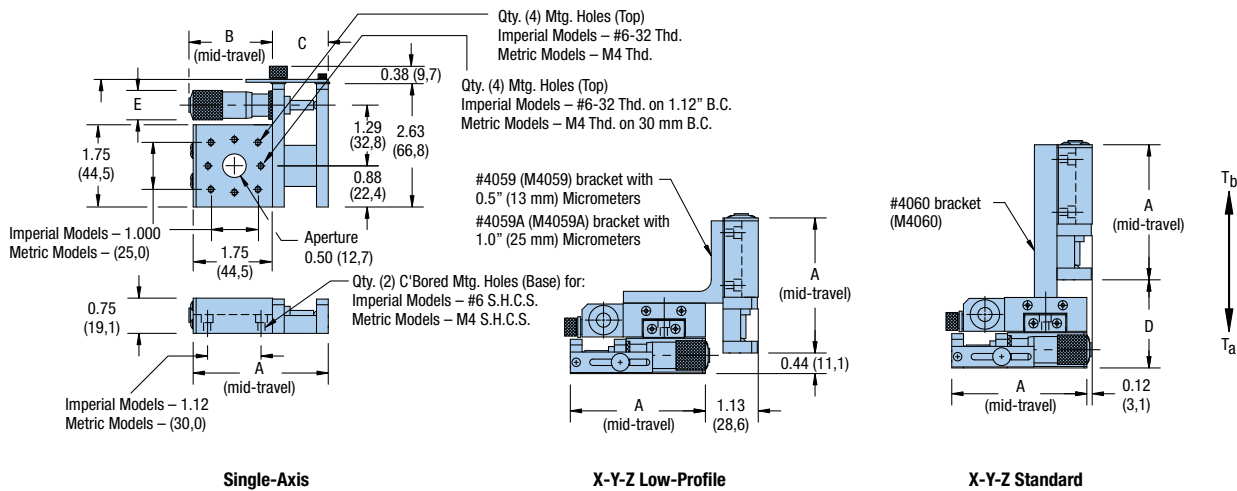

	Style	Drive Mechanism	Travel	Center Drive Dimensions — in (mm)					Side Drive Dimensions — in (mm)					
				A	B	C	D	E	A	B	C	D	E	
Imperial	Solid Top	Imperial Micrometer	0.50 in	4.42	2.68	0.90	1.88	0.54	2.97	1.78	1.19	1.88	0.54	
		Metric Micrometer	1.0 in	6.03	4.28	1.18	2.13	0.71	4.53	3.10	1.44	1.63	0.71	
			25 mm	6.03	4.28	1.18	2.13	0.71	4.53	3.10	1.44	1.63	0.71	
	Aperture	Differential Screw	0.08/0.3 in	4.12	2.37	0.88	1.88	0.62	2.97	1.44	1.19	1.88	0.62	
		Fine Screw	0.75 in	4.33	2.57	0.88	1.88	0.58	2.69	1.62	1.19	1.88	0.58	
			19 mm	110	65	22	47,8	14,7	68,0	41,0	25,0	47,8	14,7	
	Metric	Solid Top	Imperial Micrometer	0.50 in	(112)	(68)	(23)	(47,8)	(13,6)	(75,5)	(45,2)	(30,2)	(47,8)	(13,6)
			Metric Micrometer	1.0 in	(153)	(109)	(30)	(54,1)	(17,9)	(115)	(79,0)	(36,5)	(40,8)	(17,9)
				25 mm	(153)	(109)	(30)	(54,1)	(17,9)	(115,0)	(79,0)	(36,5)	(40,8)	(17,9)
Aperture		Differential Screw	2/8 mm	(105)	(60)	(22)	(47,8)	(15,7)	(75,5)	(36,0)	(30,0)	(47,8)	(15,7)	
		Fine Screw	19 mm	(110)	(65)	(22)	(47,8)	(14,7)	(68,0)	(41,0)	(25,0)	(47,8)	(14,7)	
			Metric Micrometer	13 mm	(112)	(68)	(23)	(47,8)	(13,6)	(75,5)	(45,2)	(30,0)	(47,8)	(13,6)

4100/M4100, 4200/M4200, 4300/M4300 Series

Specifications	Imperial	Metric
Travel:	0.5 – 1.0 in	13 – 25 mm
Size:		
Width	1.75 in	44,4 mm
Length (mid-travel)	4.60 – 8.28 in	114,3 – 210,3 mm
Height	0.75 in	19,0 mm
Load:		
Normal	30 – 55 lbs	13 – 25 kg
Thrust – T_a	10 lbs	4,5 kg
Thrust – T_b	3 lbs	1,4 kg
Moment – Yaw, Pitch, Roll	See page 87	See page 87
Straight line accuracy:	0.00008 in/in of travel	2 μ m/25 mm of travel
Micrometer graduations:	0.001 in	0,01 mm
Fine screw:	64 pitch	64 pitch
Weight:	0.5 – 0.8 lbs/ axis	0,2 – 0,4 kg/ axis
Construction:	Aluminum top and base/ 440C stainless steel bearings	
Mounting surface:	Precision machined	
Finish:	Black anodize	





Dimensions in (mm)

For additional end view dimensions, refer to the 4100-4300/M4100-4300 ball slide drawing, page 22. Consult factory for critical dimension concerns.

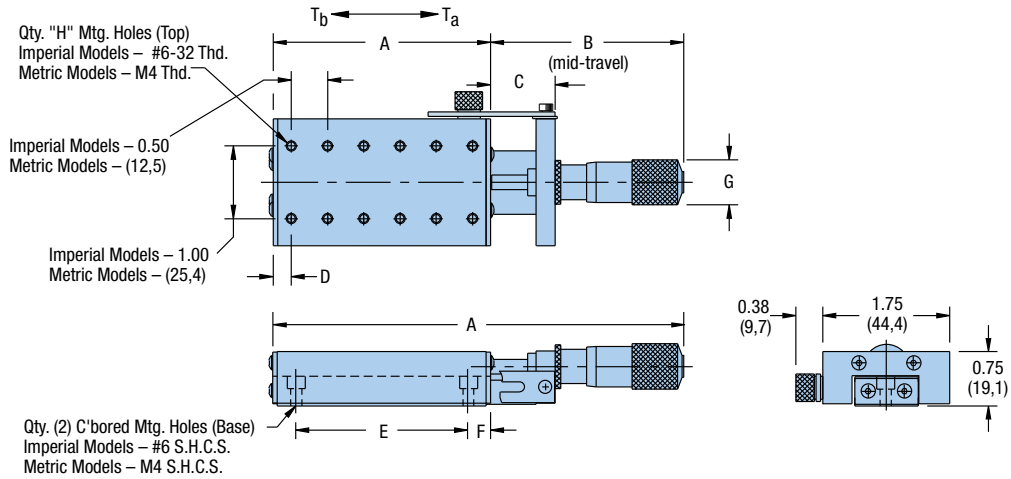

		Dimensions – in (mm)											Qty	
Drive Mechanism	Travel	Model	Load	Weight	A	B	C	D	E	F	G	H		
Imperial	Imperial Micrometer	0.50 in	30 lbs	0.5 lbs	2.00	2.68	0.89	0.25	1.38	0.31	0.54	8		
		1.0 in				4.28	1.18				0.71			
	Metric Micrometer	13 mm	42 lbs	0.6 lbs	3.00	2.68	0.89	0.25	2.38	0.31	0.54	12		
		25 mm				4.28	1.18				0.71			
	Fine Screw	0.75 in	4.28	0.89	0.58									
	Metric	Imperial Micrometer	0.50 in	13 kg	0,2 kg	(50,8)	2.68	0.89	(12,9)	(35,0)	(7,8)	0.54	6	
			1.0 in				4.28	1.18				0.71		
		Metric Micrometer	13 mm	19 kg	0,3 kg	(76,2)	2.68	0.89	(13,1)	(60,0)	(8,1)	0.54	10	
			25 mm				4.28	1.18				0.71		
		Fine Screw	0.75 in	4.28	0.89	0.58								
		Imperial	Imperial Micrometer	0.50 in	25 kg	0,4 kg	(101,6)	2.68	0.89	(13,3)	(85,0)	(8,3)	0.54	14
				1.0 in				4.28	1.18				0.71	
Metric Micrometer			13 mm	25 kg	0,4 kg	(101,6)	2.68	0.89	(13,3)	(85,0)	(8,3)	0.54	14	
			25 mm				4.28	1.18				0.71		
Fine Screw			0.75 in	4.28	0.89	0.58								

4000-DM/M4000-DM Series

Specifications	Imperial	Metric
Travel:	1.0 in	25,0 mm
Size:		
Width	1.75 in	44,4 mm
Length (mid-travel)	in	mm
Height	0.75 in	19,0 mm
Load:		
Normal	25 lbs	11 kg
Thrust – T _a	10 lbs	4,5 kg
Thrust – T _b	5 lbs	2,3 kg
Moment – Yaw, Pitch, Roll	See page 87	See page 87
Straight line accuracy:	0.00008 in/in of travel	2 μm/25 mm of travel
Micrometer graduations:	0.00005 in	0,001 mm
Weight:		
Solid Top	1.0 lb	0,45 kg
Aperture	0.8 lb	0,36 kg
Construction:	Aluminum top and base/ 440C stainless steel bearings	
Mounting surface:	Precision machined	
Finish:	Black anodize	

For additional end view dimensions, refer to the 4000/M4000 ball slide drawing, page 21. Consult factory for critical dimension concerns.



Dimensions in (mm)

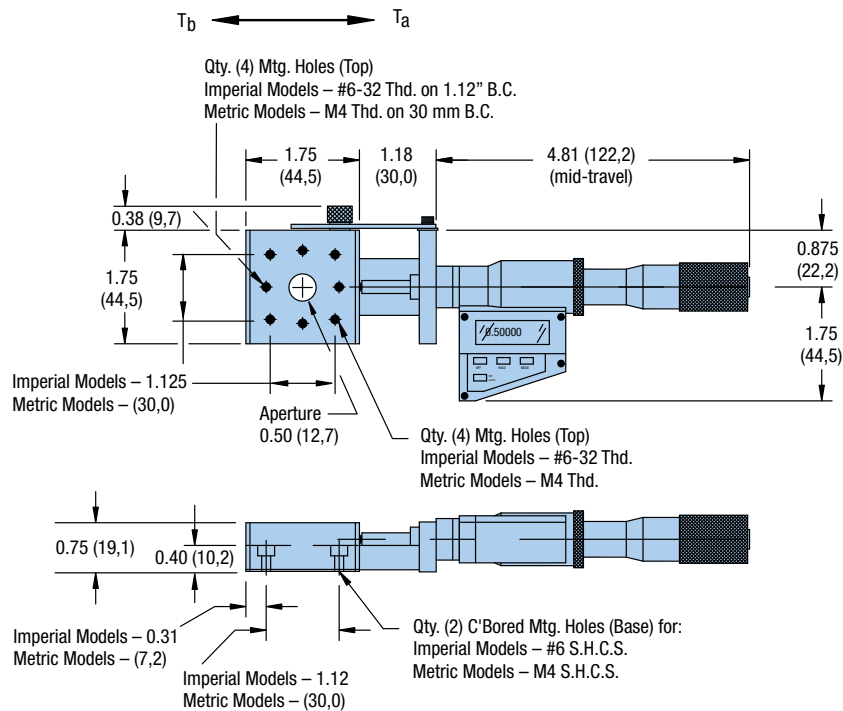

	Style	Model
Imperial	Solid Top	4004-DM
	Aperture (0.50 in)	4008-DM
Metric	Solid Top	M4004-DM
	Aperture (12,7 mm)	M4008-DM



4100-DM/M4100-DM, 4200-DM/M4200-DM, 4300-DM/M4300-DM Series

For additional end view dimensions, refer to the 4100-4300/M4100-4300 ball slide drawing, page 22. Consult factory for critical dimension concerns.

Ball Bearing Slides

Specifications	Imperial	Metric
Travel:	1.0 in	25 mm
Size:		
Width	1.75 in	44,4 mm
Length (mid-travel)	7.99 – 9.99 in	202,9 – 253,7 mm
Height	0.75 in	19,0 mm
Load:		
Normal	28 – 55 lbs	13 – 25 kg
Thrust – T _a	10 lbs	4,5 kg
Thrust – T _b	3 lbs	1,4 kg
Moment – Yaw, Pitch, Roll	See page 87	See page 87
Straight line accuracy:	0.00008 in/in of travel	2 μm/25 mm of travel
Micrometer graduations:	0.00005 in	0,001 mm
Weight:	0.9 – 1.3 lbs/ axis	0,4 – 0,6 kg/ axis
Construction:	Aluminum top and base/ 440C stainless steel bearings	
Mounting surface:	Precision machined	
Finish:	Black anodize	



Dimensions in (mm)

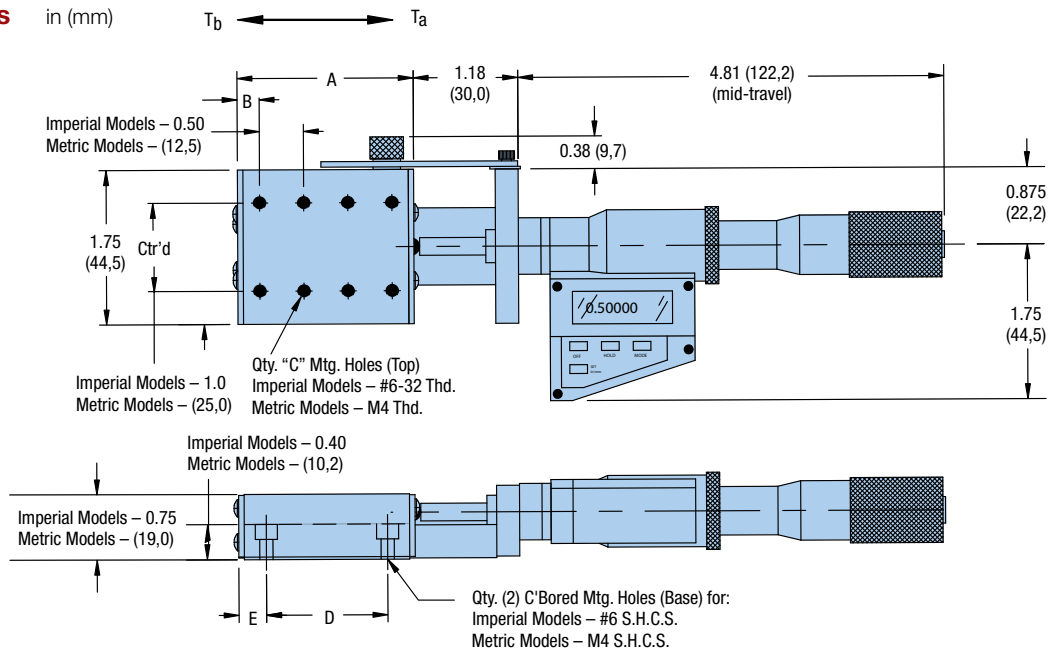

		Normal Load	Weight	Dimensions – in (mm)				
	Model			A	B	C	D	E
Imperial	4104-DM	30 lbs	0.9 lbs	2.0	0.25	8	1.38	0.31
	4204-DM	42 lbs	1.0 lbs	3.0	0.25	12	2.38	0.31
	4304-DM	50 lbs	1.3 lbs	4.0	0.25	16	3.38	0.31
Metric	M4104-DM	13 kg	0,4 kg	(50,8)	(12,9)	6	(35,0)	(7,8)
	M4204-DM	19 kg	0,5 kg	(76,2)	(13,1)	10	(60,0)	(8,1)
	M4304-DM	25 kg	0,6 kg	(101,6)	(13,3)	14	(85,0)	(8,3)

4500/M4500 Series

Specifications	Imperial	Metric
Travel:	0.5 – 1.0 in	13 – 25 mm
Size:		
Width	2.62 in	66,5 mm
Length (mid-travel)	3.75 – 6.88 in	95,5 – 174,4 mm
Height	1.00 in	25,4 mm
Load:		
Normal	62 lbs	28 kg
Thrust – T _a	10 lbs	4,5 kg
Thrust – T _b	2 lbs	0,9 kg
Moment – Yaw, Pitch, Roll	See page 87	See page 87
Straight line accuracy:	0.00008 in/in of travel	2 µm/25 mm of travel
Micrometer graduations:	0.001 in	0,01 mm
Differential screw:		
Coarse Adjustment	48 pitch	48 pitch
Fine Adjustment	336 pitch	336 pitch
Fine screw:	64 pitch	64 pitch
Weight:		
Center drive	0.72 lbs/axis	0,33 kg/axis
Side drive	0.92 lbs/axis	0,42 kg/axis
Z-Axis bracket options: (See page 124-127)		
Center drive low profile	4509	M4509
Center drive standard	4510	M4510
Side drive low profile	4559	M4559
Side drive standard	4560	M4560
Construction:	Aluminum top and base/ 440C stainless steel bearings	
Mounting surface:	Precision machined	
Finish:	Black anodize	



	Style	Drive Mechanism	Travel	Center Drive Models				Side Drive Models			
				Single Axis	Two Axis	X-Y-Z Low Profile	X-Y-Z Standard	Single Axis	Two Axis	X-Y-Z Low Profile	X-Y-Z Standard
Imperial	Solid Top	Imperial Micrometer	0.50 in	4502	4522	4532	4542	4552	4572	4582	4592
			1.0 in	4504	4524	4534	4544	4554	4574	4584	4594
		Metric Micrometer	13mm	4502M	4522M	4532M	4542M	4552M	4572M	4582M	4592M
			25 mm	4504M	4524M	4534M	4544M	4554M	4574M	4584M	4594M
	Aperture (1.0 in)	Differential Screw	0.08/0.3 in	4502D	4522D	4532D	4542D	4552D	4572D	4582D	4592D
			Fine Screw	0.75 in	4503	4523	4533	4543	4553	4573	4583
		Imperial Micrometer	0.50 in	4506	4526	4536	4546	4556	4576	4586	4596
			Metric Micrometer	13 mm	4506M	4526M	4536M	4546M	4556M	4576M	4586M
Metric	Solid Top	Metric Micrometer	13 mm	M4502M	M4522M	M4532M	M4542M	M4552M	M4572M	M4582M	M4592M
			25 mm	M4504M	M4524M	M4534M	M4544M	M4554M	M4574M	M4584M	M4594M
		Imperial Micrometer	0.50 in	M4502	M4522	M4532	M4542	M4552	M4572	M4582	M4592
			1.0 in	M4504	M4524	M4534	M4544	M4554	M4574	M4584	M4594
		Differential Screw	2/8 mm	M4502D	M4522D	M4532D	M4542D	M4552D	M4572D	M4582D	M4592D
	Fine Screw	19 mm	M4503	M4523	M4533	M4543	M4553	M4573	M4583	M4593	
	Aperture (25,4 mm)	Metric Micrometer	13 mm	M4506M	M4526M	M4536M	M4546M	M4556M	M4576M	M4586M	M4596M
		Imperial Micrometer	0.50 in	M4506	M4526	M4536	M4546	M4556	M4576	M4586	M4596
		Differential Screw	2/8 mm	M4506D	M4526D	M4536D	M4546D	M4556D	M4576D	M4586D	M4596D
		Fine Screw	19 mm	M4507	M4527	M4537	M4547	M4557	M4577	M4587	M4597



Dimensions in (mm)

For additional end view dimensions, refer to the 4500/M4500 ball slide drawing, page 23. Consult factory for critical dimension concerns.

Ball Bearing Slides

Center Drive

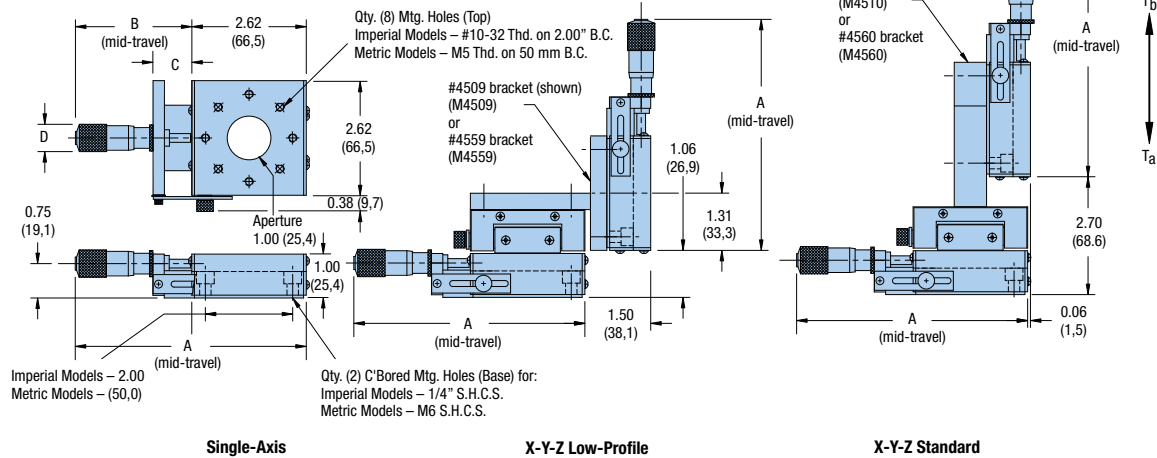

Side Drive

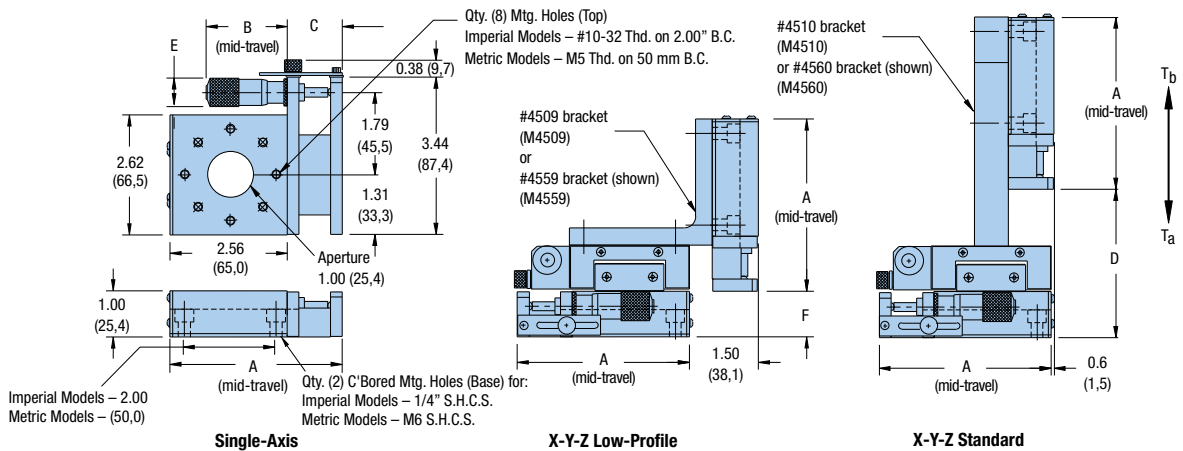

Style	Drive Mechanism	Travel	Center Drive Dimensions in (mm)				Side Drive Dimensions in (mm)							
			A	B	C	D	A	B	C	D	E	F		
Imperial	Solid Top	Imperial Micrometer	0.50 in	5.29	2.68	0.89	0.54	3.75	1.78	1.19	3.25	0.54	1.00	
		Metric Micrometer	13 mm	5.29	2.68	0.89	0.54	3.75	1.78	1.19	3.25	0.54	1.00	
	Aperture	Differential Screw	0.08/0.3 in	5.00	2.37	0.89	0.62	3.75	1.44	1.19	3.25	0.62	1.00	
		Fine Screw	0.75 in	5.23	2.60	0.89	0.58	3.75	1.72	1.19	3.25	0.58	1.00	
	Metric	Solid Top	Metric Micrometer	13 mm	(134,4)	(67,7)	(22,6)	(13,6)	(95,5)	(45,1)	(30,0)	(82,6)	(12,7)	(25,4)
			Imperial Micrometer	0.50 in	(134,4)	(67,7)	(22,6)	(13,6)	(95,5)	(45,1)	(30,0)	(82,6)	(12,7)	(25,4)
Metric	Aperture	Differential Screw	2/8 mm	(127,0)	(60,0)	(22,0)	(15,7)	(95,5)	(36,0)	(30,0)	(82,6)	(15,7)	(25,4)	
		Fine Screw	19 mm	(130,0)	(64,0)	(22,0)	(14,7)	(95,5)	(36,0)	(30,0)	(82,6)	(15,0)	(25,4)	
	Imperial	Solid Top	Metric Micrometer	13 mm	(134,4)	(67,7)	(22,6)	(13,6)	(95,5)	(45,1)	(30,0)	(82,6)	(12,7)	(25,4)
			Imperial Micrometer	0.50 in	(134,4)	(67,7)	(22,6)	(13,6)	(95,5)	(45,1)	(30,0)	(82,6)	(12,7)	(25,4)
	Metric	Aperture	Differential Screw	2/8 mm	(127,0)	(60,0)	(22,0)	(15,7)	(95,5)	(36,0)	(30,0)	(82,6)	(15,7)	(25,4)
			Fine Screw	19 mm	(130,0)	(64,0)	(22,0)	(14,7)	(95,5)	(36,0)	(30,0)	(82,6)	(15,0)	(25,4)

4600/M4600, 4700/M4700, 4800/M4800 Series

Specifications	Imperial	Metric
Travel:	0.5 – 1.0 in	13 – 25 mm
Size:		
Width	2.62 in	66,5 mm
Length (mid-travel)	6.50 – 10.28 in	164,1 – 261,1 mm
Height	1.00 in	25,4 mm
Load:		
Normal	88 – 123 lbs	40 – 56 kg
Thrust – T_a	30 lbs	13,6 kg
Thrust – T_b	2 lbs	0,9 kg
Moment – Yaw, Pitch, Roll	See page 87	See page 87
Straight line accuracy:	0.00008 in/in of 2 μ m/25 mm of travel	
Micrometer graduations:	0.001 in	0,01 mm
Fine screw:	64 pitch	64 pitch
Weight:	1.1 – 1.5 lbs/ axis	0,5 – 0,7 kg/ axis
Construction:	Aluminum top and base/ 440C stainless steel bearings	
Mounting surface:	Precision machined	
Finish:	Black anodize	





Dimensions in (mm)

For additional end view dimensions, refer to the 4600-4800/M4600-4800 ball slide drawing, page 24. Consult factory for critical dimension concerns.

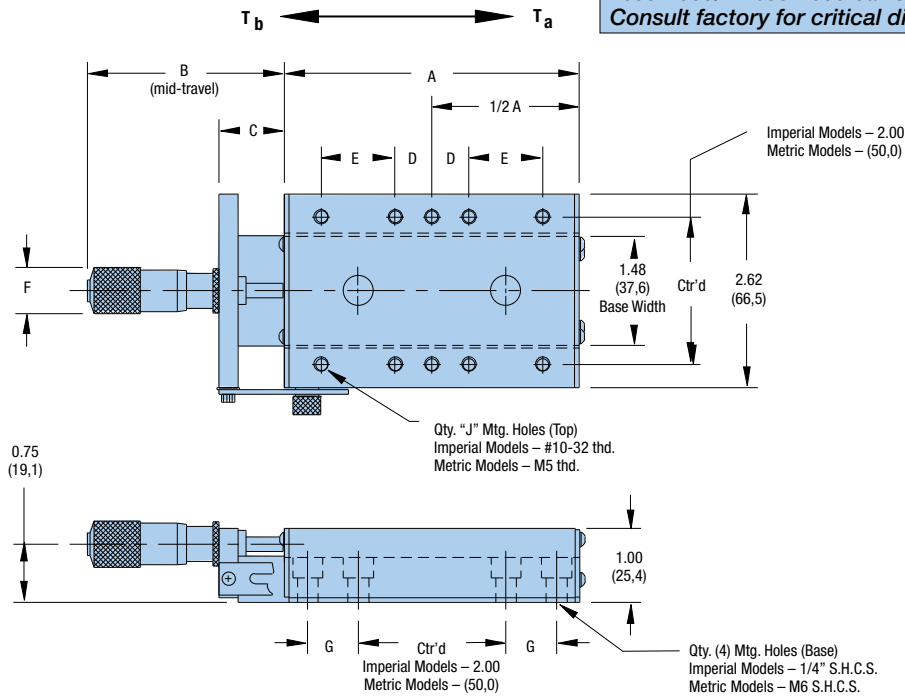

						Dimensions — in (mm)						Qty	
Drive Mechanism	Travel	Model	Load lb (kg)	Weight lb (kg)	A	B	C	D	E	F	G	J	
Imperial	Imperial Micrometer	0.50 in	88	1.1	4.00	2.68	0.89	0.50	—	0.55	0.69	6	
		1.0 in											
	Metric Micrometer	13 mm	106	1.2	5.00	2.68	0.89	1.00	—	0.55	1.19	6	
		25 mm											
	Fine Screw	0.75 in			2.50	0.88			0.59				
	Imperial	Imperial Micrometer	0.50 in			2.68	0.89			0.55			
			1.0 in			4.28	1.18			0.62			
		Metric Micrometer	13 mm	123	1.5	6.00	2.68	0.89	0.50	1.00	0.55	1.69	10
			25 mm										
	Fine Screw	0.75 in			2.50	0.88			0.59				
	Metric	Metric Micrometer	13 mm	(40)	(0,5)	(101,6)	(67,7)	(22,6)	(12,5)	—	(14,0)	(12,5)	6
			25 mm										
Imperial Micrometer		0.50 in	(56)	(0,7)	(152,4)	(67,7)	(22,6)	(12,5)	(25,0)	(14,0)	(25,0)	10	
		1.0 in											
Fine Screw		0.75 in			(63,5)	(22,3)			(15,0)				
Metric		Metric Micrometer	13 mm			(67,7)	(22,6)			(14,0)			
			25 mm			(108,7)	(29,9)			(15,7)			
		Imperial Micrometer	0.50 in	(48)	(0,6)	(127,0)	(67,7)	(22,6)	(25,0)	—	(14,0)	(25,0)	6
			1.0 in										
Fine Screw		0.75 in			(63,5)	(22,3)			(15,0)				
Metric		Metric Micrometer	13 mm			(67,7)	(22,6)			(14,0)			
			25 mm			(108,7)	(29,9)			(15,7)			
	Imperial Micrometer	0.50 in	(56)	(0,7)	(152,4)	(67,7)	(22,6)	(12,5)	(25,0)	(14,0)	(25,0)	10	
		1.0 in											
Fine Screw	0.75 in			(63,5)	(22,3)			(15,0)					

4500-DM/M4500-DM Series

For additional end view dimensions, refer to the 4500/M4500 ball slide drawing, page 23. Consult factory for critical dimension concerns.

Specifications	Imperial	Metric
Travel:	1.0 in	25 mm
Size:		
Width	2.62 in	66,5 mm
Length (mid-travel)	8.58 in	218,0 mm
Height	1.00 in	25,4 mm
Load:		
Normal	62 lbs	28 kg
Thrust – T _a	10 lbs	4,5 kg
Thrust – T _b	2 lbs	0,9 kg
Moment – Yaw, Pitch, Roll	See page 87	See page 87
Straight line accuracy:	0.00008 in/in of travel	2 µm/25 mm of travel
Micrometer graduations:	0.00005 in	0,001 mm
Weight:	1.4 lbs/axis	0,63 kg/axis
Construction:	Aluminum top and base/ 440C stainless steel bearings	
Mounting surface:	Precision machined	
Finish:	Black anodize	



Dimensions in (mm)

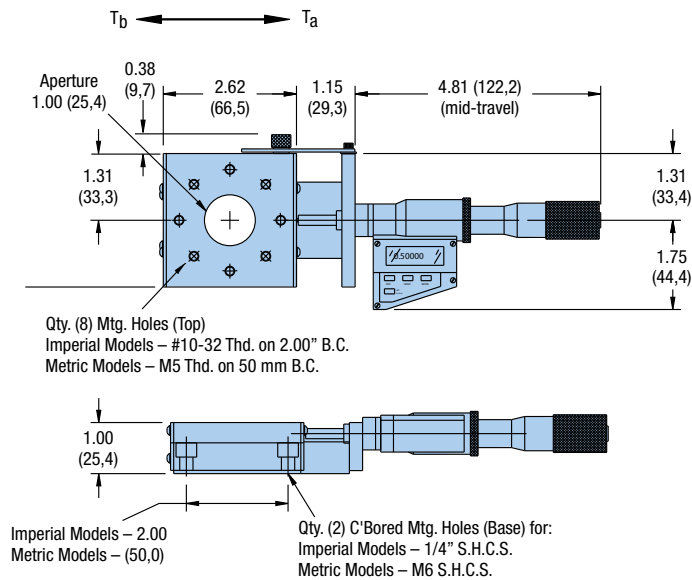

	Style	Model
Imperial	Solid Top	4504-DM
	Aperture (1.0 in)	4508-DM
Metric	Solid Top	M4504-DM
	Aperture (25,4 mm)	M4508-DM



4600-DM/M4600-DM, 4700-DM/M4700-DM, 4800-DM/M4800-DM Series

For additional end view dimensions, refer to the 4600-4800/M4600-4800 ball slide drawing, page 24. Consult factory for critical dimension concerns.

Ball Bearing Slides

Specifications	Imperial	Metric
Travel:	1.0 in	25 mm
Size:		
Width	2.62 in	66,5 mm
Length (mid-travel)	9.96 – 11.96 in	253,1 – 303,9 mm
Height	1.00 in	
Load:		
Normal	88 – 123 lbs	40 – 56 kg
Thrust – T _a	30 lbs	13,6 kg
Thrust – T _b	2 lbs	0,9 kg
Moment – Yaw, Pitch, Roll	See page 87	See page 87
Straight line accuracy:	0.00008 in/in of 2 μm/25 mm of travel	
Micrometer graduations:	0.00005 in	0,001 mm
Weight:	1.6 – 2.0 lbs/ axis	0,73 – 0,91 kg/ axis
Construction:	Aluminum top and base/ 440C stainless steel bearings	
Mounting surface:	Precision machined	
Finish:	Black anodize	

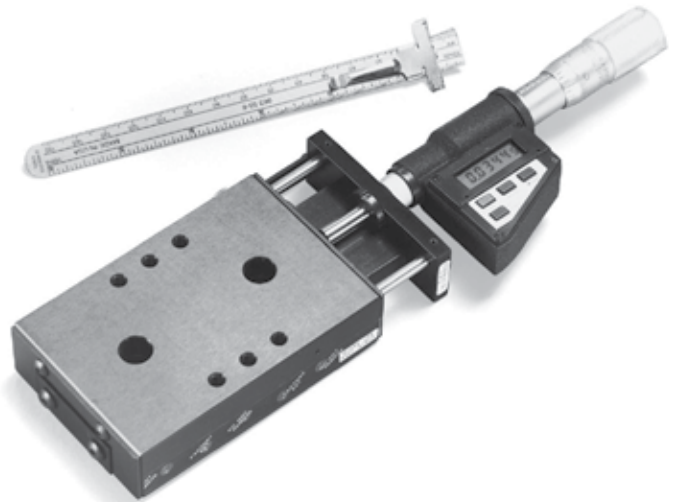

Dimensions in (mm)

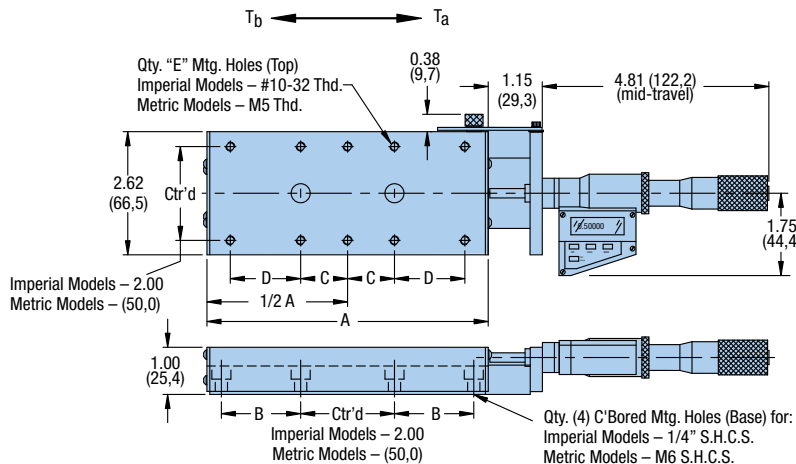

		Dimensions — in (mm)						Qty
	Model	Load	Weight	A	B	C	D	E
Imperial	4604-DM	88 lbs	1.6 lbs	4.00	0.69	0.50	—	6
	4704-DM	106 lbs	1.8 lbs	5.00	1.19	1.00	—	6
	4804-DM	123 lbs	2.0 lbs	6.00	1.69	0.50	1.00	10
Metric	M4604-DM	40 kg	0,73 kg	(101,6)	(12,5)	(12,5)	—	6
	M4704-DM	48 kg	0,82 kg	(127,0)	(25,0)	(25,0)	—	6
	M4804-DM	56 kg	0,91 kg	(152,4)	(25,0)	(12,5)	(25,0)	10

4400/M4400 Series

Specifications	Imperial	Metric
Travel:	1.0 – 2.0 in	25 – 50 mm
Size:		
Width	5.00 in	127,0 mm
Length (mid-travel)	6.0 – 11.28 in	152,4 – 286,0 mm
Height	1.00 in	25,4 mm
Load:		
Normal	105 lbs	48 kg
Thrust – T _a	30 lbs	13,6 kg
Thrust – T _b	2.5 lbs	1,1 kg
Moment – Yaw, Pitch, Roll	See page 88	See page 88
Straight line accuracy:	0.00008 in/in of 2 μm/25 mm of travel	
Micrometer graduations:	0.001 in	0,01 mm
Weight:	2.7 lbs/axis	1,2 kg/axis
Z-Axis bracket options: (See page 124-127)	4499	M4499
Construction:	Aluminum top and base/ 440C stainless steel bearings	
Mounting surface:	Precision machined	
Finish:	Black anodize	



	Style	Drive Mechanism	Travel	Center Drive Models			Side Drive Models		
				Single Axis	Two Axis	Three Axis	Single Axis	Two Axis	Three Axis
Imperial	Solid Top	Imperial Micrometer	1.0 in	4411	4421	4431	4416	4426	4436
			2.0 in	4412	4422	4432	4417	4427	4437
		Metric Micrometer	25 mm	4413	4423	4433	4418	4428	4438
			50 mm	4414	4424	4434	4419	4429	4439
	Aperture (2.0 in)	Imperial Micrometer	1.0 in	4451	4461	4471	4456	4466	4476
			2.0 in	4452	4462	4472	4457	4467	4477
Metric Micrometer		25 mm	4453	4463	4473	4458	4468	4478	
		50 mm	4454	4464	4474	4459	4469	4479	
Metric	Solid Top	Metric Micrometer	25 mm	M4413	M4423	M4433	M4418	M4428	M4438
			50 mm	M4414	M4424	M4434	M4419	M4429	M4439
		Imperial Micrometer	1.0 in	M4411	M4421	M4431	M4416	M4426	M4436
			2.0 in	M4412	M4422	M4432	M4417	M4427	M4437
	Aperture (50,8 mm)	Metric Micrometer	25 mm	M4453	M4463	M4473	M4458	M4468	M4478
			50 mm	M4454	M4464	M4474	M4459	M4469	M4479
		Imperial Micrometer	1.0 in	M4451	M4461	M4471	M4456	M4466	M4476
			2.0 in	M4452	M4462	M4472	M4457	M4467	M4477



Dimensions in (mm)

For additional end view dimensions, refer to the 4400/M4400 ball slide drawing, page 26. Consult factory for critical dimension concerns.

Ball Bearing Slides

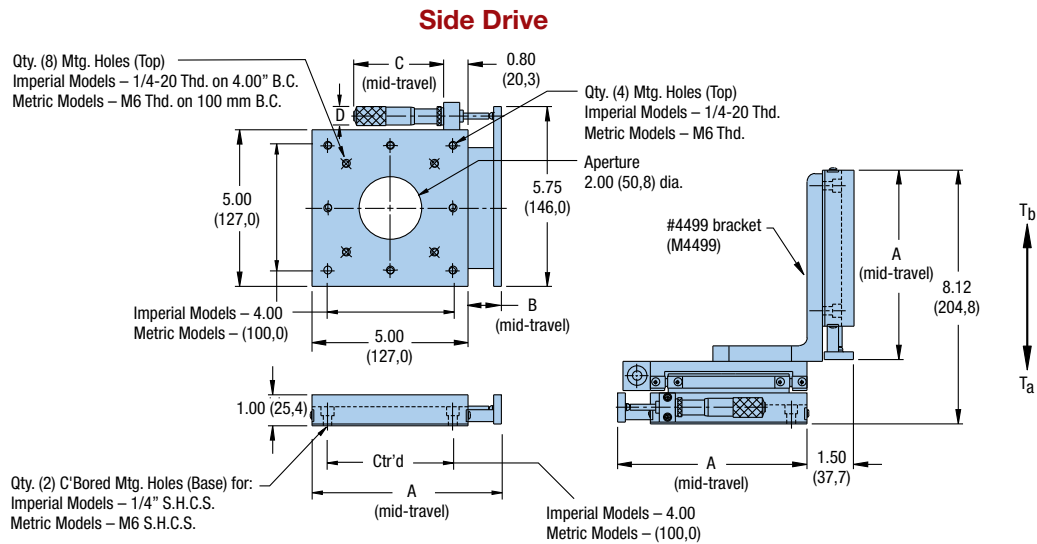
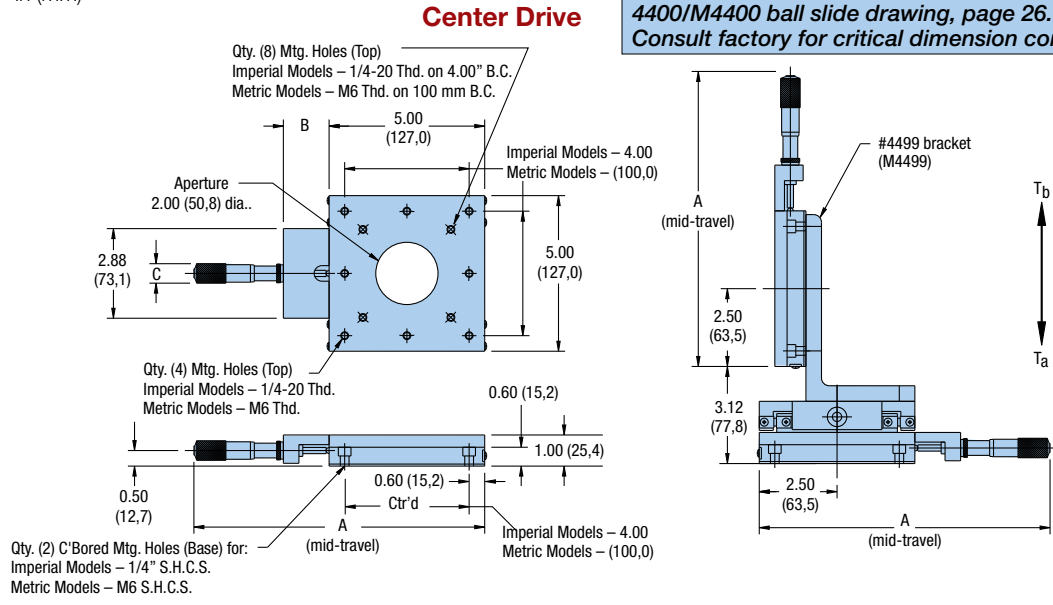

Style	Drive Mechanism	Travel	Center Drive Dimensions – in (mm)			Side Drive Dimensions – in (mm)				
			A	B	C	A	B	C	D	
Imperial	Solid Top	Imperial Micrometer	1.0 in	9.28	1.47	0.73	6.0	1.00	2.84	0.73
		Metric Micrometer	25 mm	11.26	1.98	0.63	6.5	1.53	4.36	0.63
	Aperture	Imperial Micrometer	25 mm	9.28	1.47	0.71	6.0	1.00	2.84	0.71
		Metric Micrometer	50 mm	11.28	2.00	0.73	6.5	1.50	4.36	0.73
Metric	Solid Top	Metric Micrometer	25 mm	(236,0)	(37,4)	(18,5)	(152,4)	(25,4)	(72,0)	(18,5)
		Metric Micrometer	50 mm	(286,0)	(50,3)	(16,0)	(166,0)	(38,9)	(110,8)	(16,0)
		Imperial Micrometer	1.0 in	(236,0)	(38,0)	(18,0)	(152,4)	(25,0)	(72,0)	(18,0)
		Imperial Micrometer	2.0 in	(286,0)	(50,0)	(18,5)	(166,0)	(38,0)	(110,8)	(18,5)
	Aperture	Metric Micrometer	25 mm	(236,0)	(38,0)	(18,5)	(152,4)	(25,0)	(72,0)	(18,5)
		Metric Micrometer	50 mm	(286,0)	(50,0)	(16,0)	(166,0)	(38,0)	(110,8)	(16,0)
		Imperial Micrometer	1.0 in	(236,0)	(38,0)	(18,0)	(152,4)	(25,0)	(72,0)	(18,0)
		Imperial Micrometer	2.0 in	(286,0)	(50,0)	(18,5)	(166,0)	(38,0)	(110,8)	(18,5)

4400-DM/M4400-DM Series

Specifications	Imperial	Metric
Travel:	1.0 – 2.0 in	25 – 50 mm
Size:		
Width	5.00 in	127,0 mm
Length (mid-travel)		
1.0" (25 mm)	11.28 in	286.5 mm
2.0" (50 mm)	14.16 in	542.1 mm
Height	1.00 in	25,4 mm
Load:		
Normal	105 lbs	48 kg
Thrust – T _a	30 lbs	13,6 kg
Thrust – T _b	2.0 lbs	0,9 kg
Moment – Yaw, Pitch, Roll	See page 88	See page 88
Straight line accuracy:	0.00008 in/in of travel	2 µm/25 mm of travel
Micrometer graduations:	0.00005 in	0,001 mm
Weight:	3.1 lbs/axis	1,4 kg/axis
Construction:	Aluminum top and base/ 440C stainless steel bearings	
Mounting surface:	Precision machined	
Finish:	Black anodize	

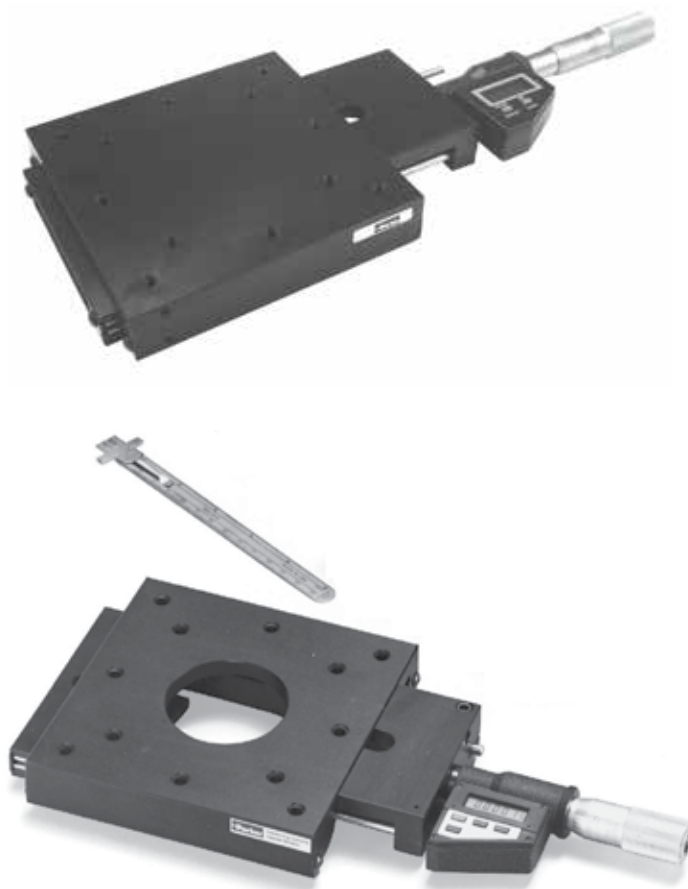

	Style	Model	Travel
Imperial	Solid Top	4410-DM	1.0 in
		4412-DM	2.0 in
	Aperture (1.0 in)	4450-DM	1.0 in
		4452-DM	2.0 in
Metric	Solid Top	M4410-DM	25 mm
		M4412-DM	50 mm
	Aperture (25,4 mm)	M4450-DM	25 mm
		M4452-DM	50 mm



Dimensions in (mm)

For additional end view dimensions, refer to the 4400/M4400 ball slide drawing, page 26. Consult factory for critical dimension concerns.

1.0 in (25 mm) Travel Models

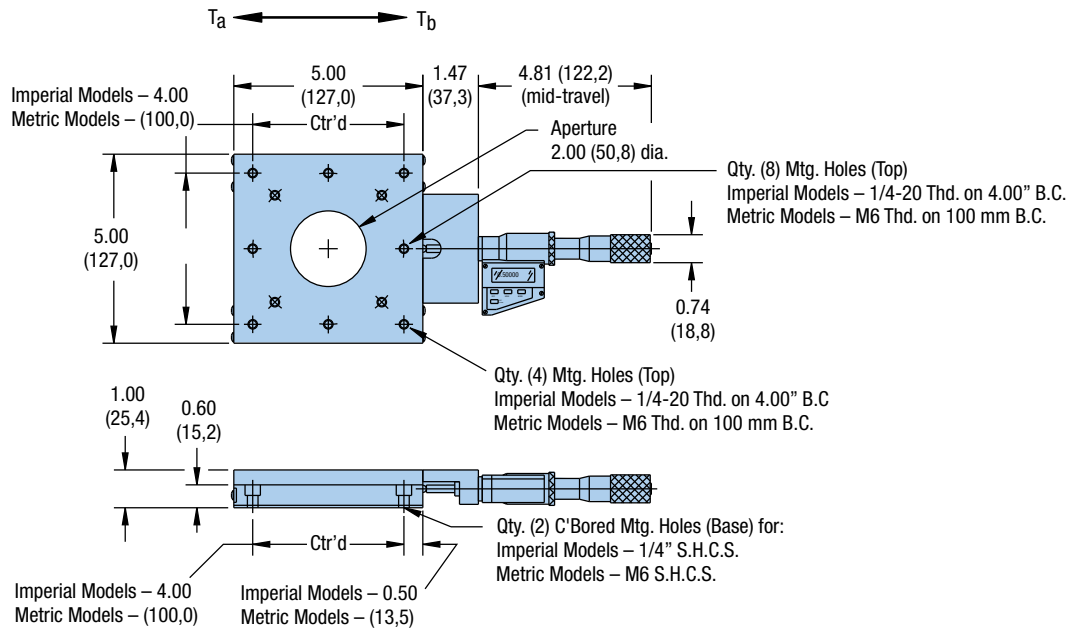

2.0 in (50 mm) Travel Models

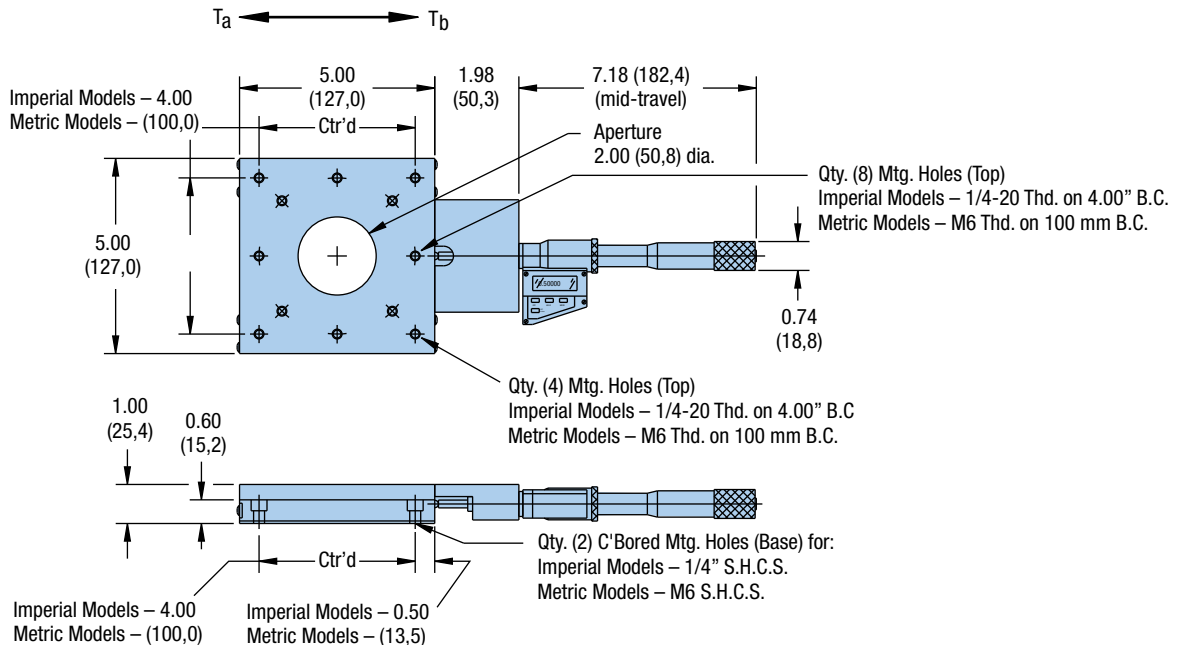

4900/M4900 Series

Specifications	Imperial	Metric
Travel:	1.0 – 2.0 in	25 – 50 mm
Size:		
Width	6.00 in	152,4 mm
Length (mid-travel)	9.59 – 11.11 in	243,6 – 282,2 mm
Height	2.00 in	50,8 mm
Load:		
Normal	100 lbs	45 kg
Thrust T_a (Std. thimble)	30 lbs	13,6 kg
Thrust T_b (Std. thimble)	3.0 lbs	1,36 kg
Thrust T_a (Std. thimble)	50 lbs	23,0 kg
Thrust T_b (Std. thimble)	3.0 lbs	1,36 kg
Moment – Yaw, Pitch, Roll	See page 88	See page 88
Straight line accuracy:	0.00008 in/in of travel	2 μ m/25 mm of travel
Micrometer graduations:		
Standard thimble	0.001 in	0,01 mm
Large thimble	0.0001 in	0,001 mm
Weight:	7 lbs/axis	1,4 kg/axis
Construction:	Aluminum top and base/ 440C stainless steel bearings	
Mounting surface:	Precision machined	
Finish:	Black anodize	



Large thimble (left) and standard thimble with optional position lock (right). To order the optional lock, add -L to the model number selected from the chart below.

Consult factory for critical dimension concerns.

Dimensions

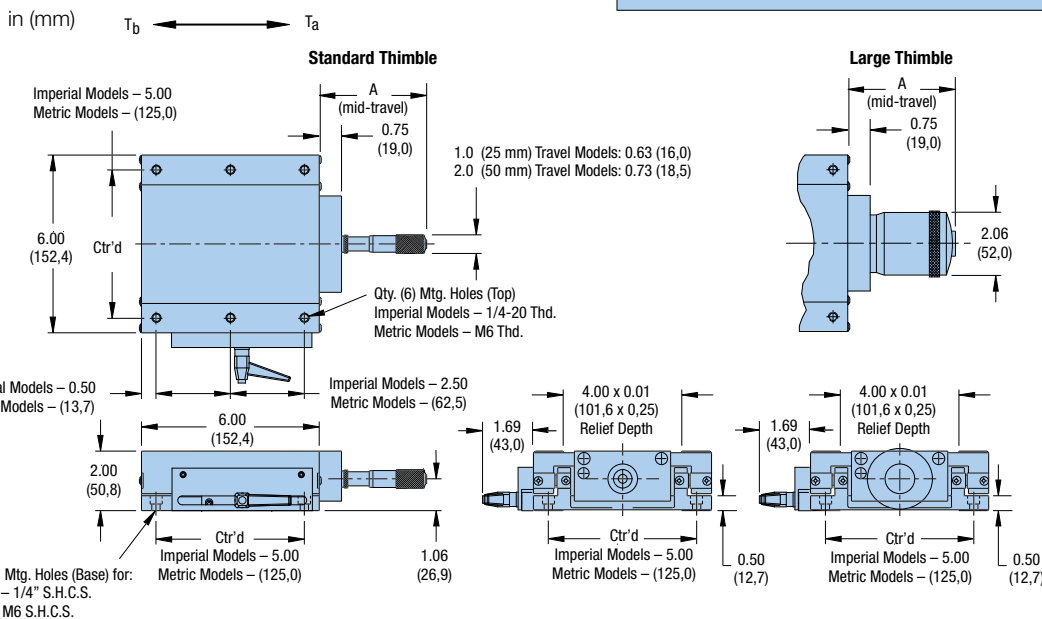

	Drive Mechanism	Travel	Standard Thimble		Large Thimble	
			Model*	Dimension A – in (mm)	Model*	Dimension A – in (mm)
Imperial	Imperial Micrometer	1.0 in	4914	3.59	4910	4.44
		2.0 in	4915	5.11	4911	5.94
	Metric Micrometer	25 mm	4916	3.59	4912	4.44
		50 mm	4917	5.11	4913	5.94
Metric	Metric Micrometer	25 mm	M4916	(91,2)	M4912	(112,8)
		50 mm	M4917	(1289,8)	M4913	(150,9)
	Imperial Micrometer	1.0 in	M4914	(91,2)	M4910	(112,8)
		2.0 in	M4915	(129,8)	M4911	(150,9)

* Add -L to model number for optional position lock.



Ball Bearing Slides

4900-DM/M4900-DM Series

Specifications	Imperial	Metric
Travel:	2.0 in	50 mm
Size:		
Width	6.00 in	152,4 mm
Length (mid-travel)	13.93 in	353,8 mm
Height	2.00 in	50,8 mm
Load:		
Normal	100 lbs	45 kg
Thrust T_a	50 lbs	23,0 kg
Thrust - T_b	3.0 lbs	1,36 kg
Moment - Yaw, Pitch, Roll	See page 88	See page 88
Straight line accuracy:	0.00008 in/in of travel	2 μ m/25 mm of travel
Micrometer graduations:		
Large thimble	0.0001 in	0,001 mm
Weight:	7 lbs/axis	3,2 kg/axis
Z-Axis bracket options: (See page 124-127)	4990-04	M4990-04
Construction:	Aluminum top and base/ 440C stainless steel bearings	
Mounting surface:	Precision machined	
Finish:	Black anodize	



Digital micrometer positioner shown with optional position lock. To order the optional lock, add -L to the model number selected from the chart below.

Consult factory for critical dimension concerns.

Dimensions in (mm)

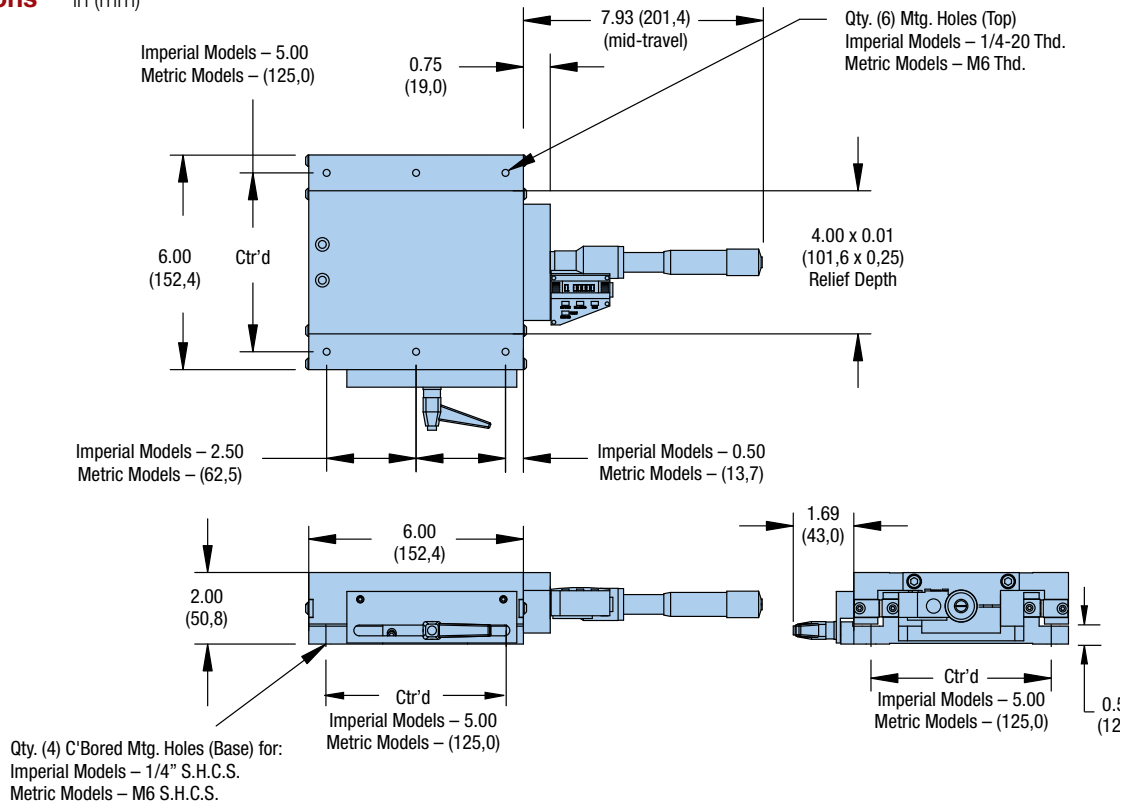

Model*	
Imperial	4911-DM
Metric	M4911-DM

* Add -L to model number for optional position lock.

4900/M4900 Series

Specifications	Imperial	Metric
Travel:	4.0 – 12.0 in	100,0 – 300,0 mm
Size:		
Width	6.00 in	152,4 mm
Length	9.39 – in	mm
Height	2.00 in	50,8 mm
Load:		
Normal	100 – 294 lbs	45 – 133 kg
Thrust T_a	30 lbs	13,6 kg
Thrust – T_b	30 lbs	13,6 kg
Moment – Yaw, Pitch, Roll	See page 88	See page 88
Straight line accuracy:	0.00008 in/in of travel	2 μ m/25 mm of travel
Readout graduations:	0.001 in	0,01 mm
Weight:	4 – 12 lbs/axis	1,8 – 5,4 kg/axis
Z-Axis bracket options: (See page 124-127)	4990-04/-12	M4990-04/-12
Construction:	Aluminum top and base/ 440C stainless steel bearings	
Mounting surface:	Precision machined	
Finish:	Black anodize	



Lead screw drive positioner with readout (left); positioner with no readout and optional position lock (right). To order the optional lock, add -L to the model number selected from the chart below.

Consult factory for critical dimension concerns.

Dimensions

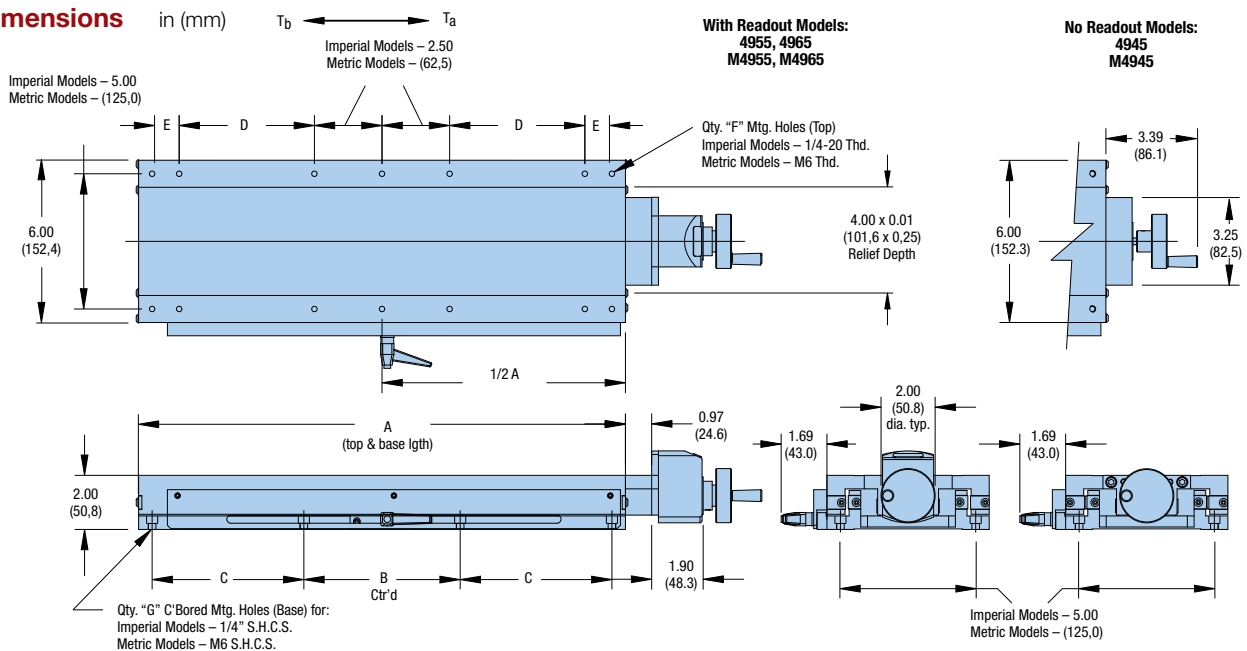

	No Readout Model*	Imperial Readout Model*	Metric Readout Model*	Travel in (mm)	Load lbs (kg)	Weight lbs (kg)	Dimensions – in (mm)					Qty F	Qty G
							A	B	C	D	E		
Imperial	4945-04	4955-04	4965-04	4.0	100	4.0	6.00	5.00	—	—	—	6	4
	4945-06	4955-06	4965-06	6.0	154	6.0	9.00	5.00	1.50	1.50	—	10	8
	4945-08	4955-08	4965-08	8.0	205	8.0	12.00	5.00	3.00	2.50	—	10	8
	4945-10	4955-10	4965-10	10.0	243	10.0	15.00	6.00	4.00	2.50	2.00	14	8
	4945-12	4955-12	4965-12	12.0	294	12.0	18.00	7.00	5.00	5.00	1.00	14	8
Metric	M4945-04	M4955-04	M4965-04	(100,0)	(45)	(1,8)	(152,4)	(125,0)	—	—	—	6	4
	M4945-06	M4955-06	M4965-06	(150,0)	(70)	(2,7)	(228,6)	(125,0)	(37,5)	(37,5)	—	10	8
	M4945-08	M4955-08	M4965-08	(200,0)	(93)	(3,6)	(304,8)	(125,0)	(75,0)	(62,5)	—	10	8
	M4945-10	M4955-10	M4965-10	(250,0)	(110)	(4,5)	(381,0)	(150,0)	(100,0)	(62,5)	(50,0)	14	8
	M4945-12	M4955-12	M4965-12	(300,0)	(133)	(5,4)	(457,2)	(175,0)	(125,0)	(125,0)	(25,0)	14	8

* Add -L to model number for optional position lock.





Yaw, Pitch, Roll

Yaw & Pitch Roll

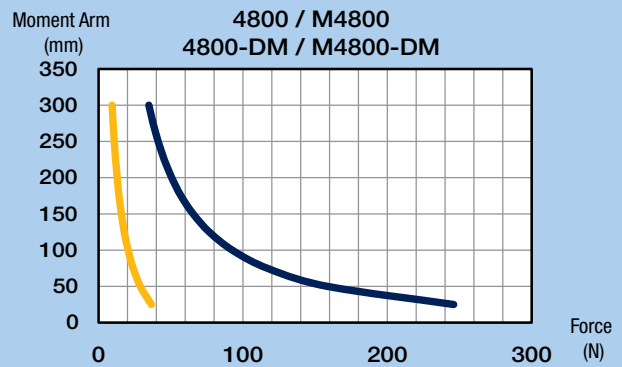
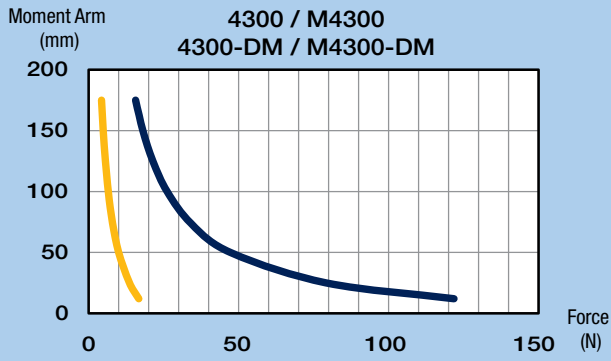
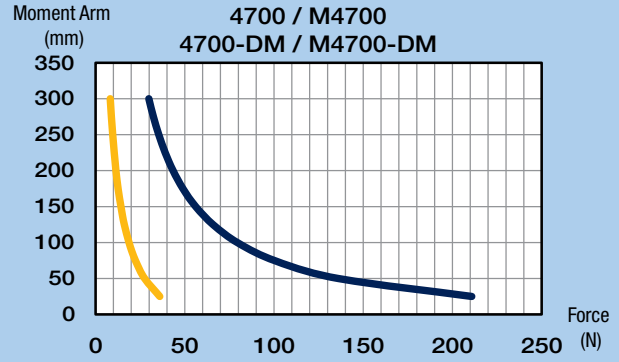
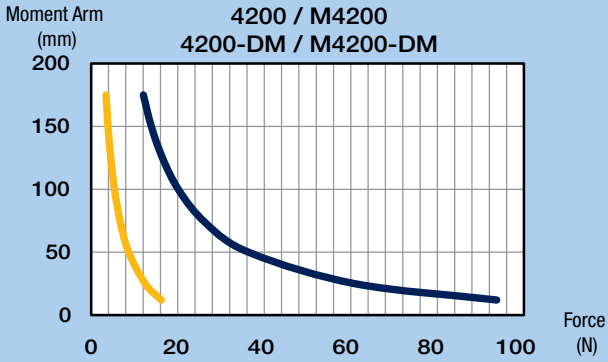
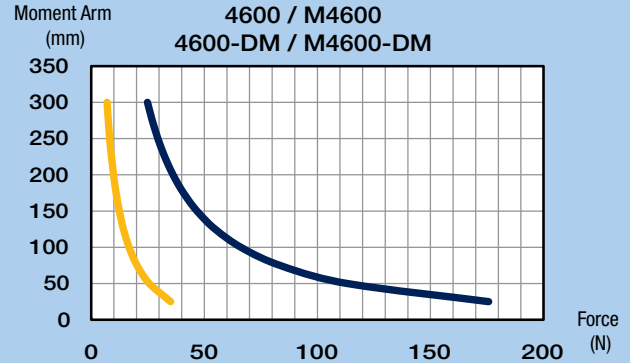
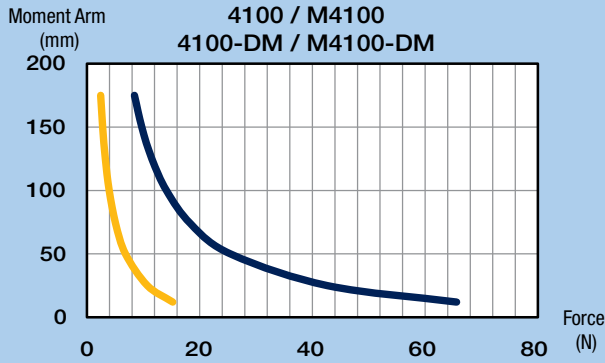
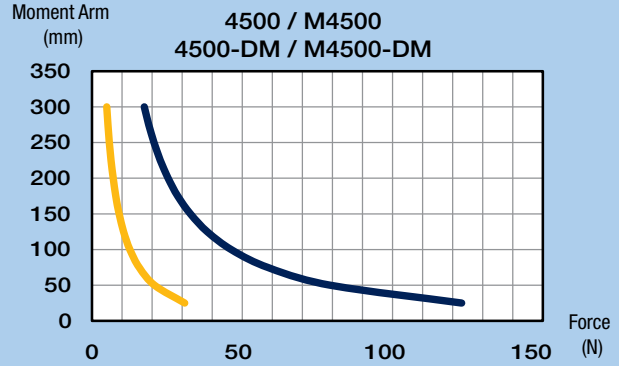
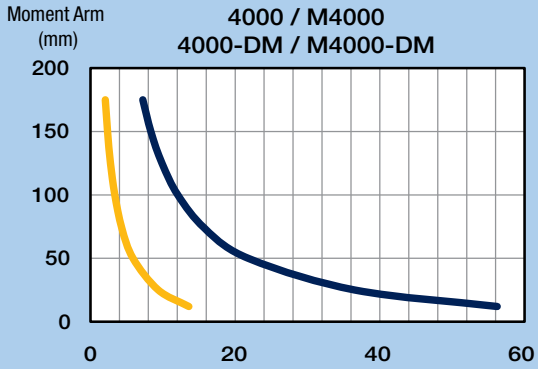

Yaw, Pitch, Roll

Yaw & Pitch **Roll**

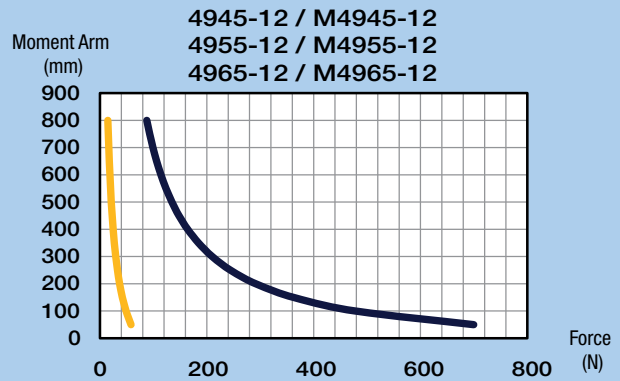
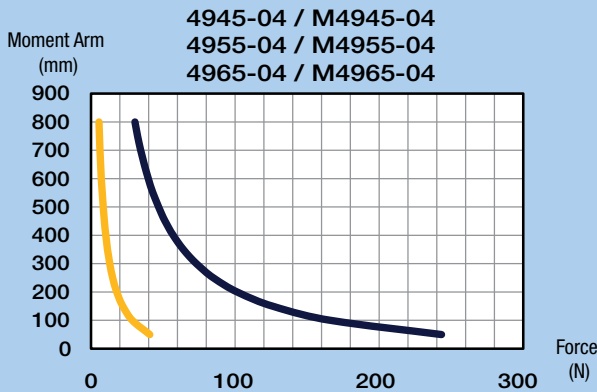
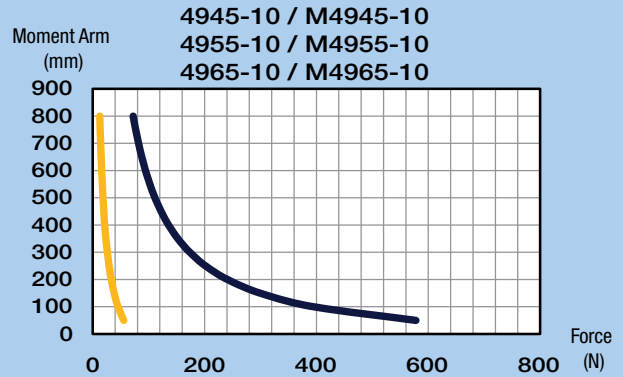
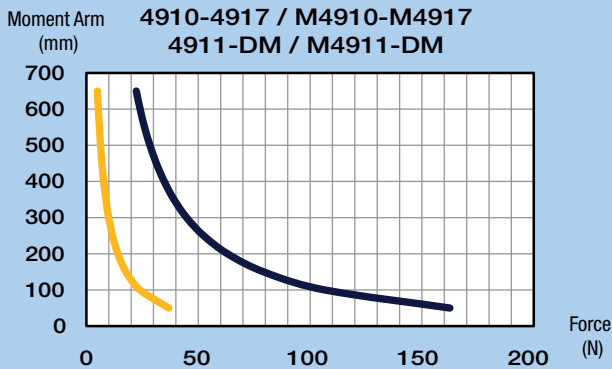
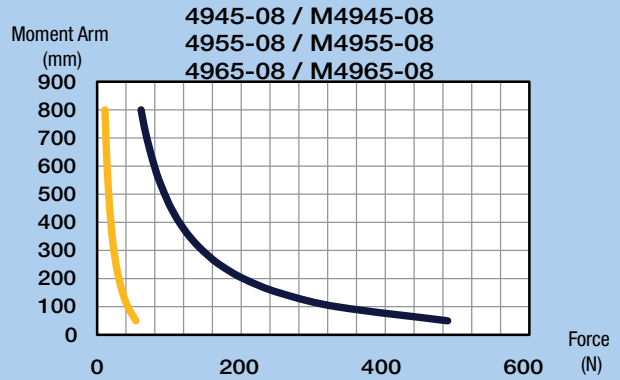
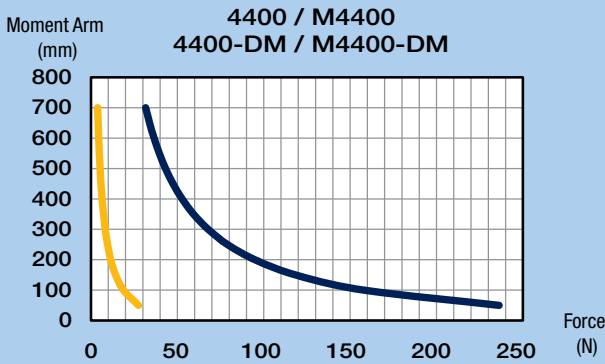
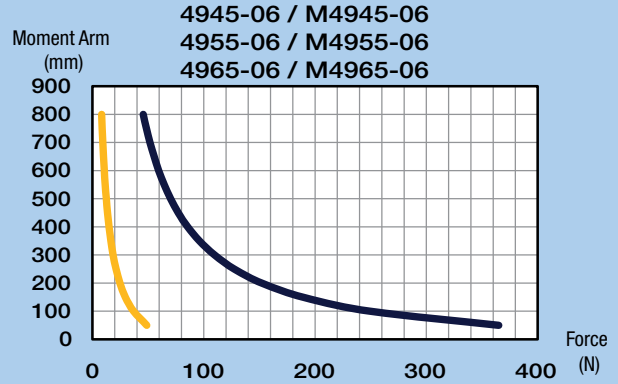
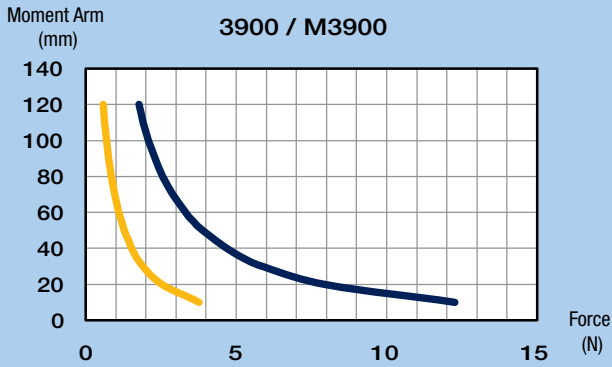

Crossed Roller Bearing Positioners

Parker precision crossed roller stages provide controlled, precise point-to-point positioning along a linear axis. Stages are comprised of two basic components: a precision linear crossed roller slide which serves as a linear bearing and guide, and a drive mechanism which accurately moves and positions the slide top along the linear axis. Crossed roller positioning stages offer exceptional load carrying capability, approximately 2 to 2 1/2 times that of comparably sized ball bearing stages. Additionally, crossed roller stages provide up to five times the life expectancy of the ball bearing stages without degradation of performance. Parker crossed roller stages are rated for over 100 million inches of travel at specified load.

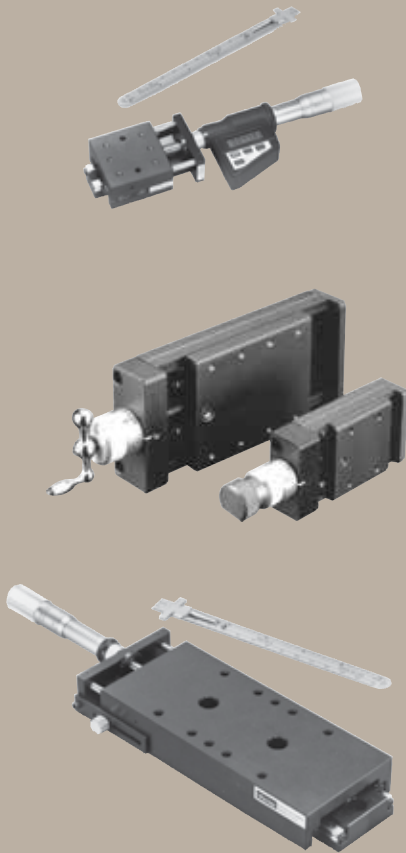

Contents

90-91	Overview
92-96	1.75" (44,5 mm) Wide
97	1.97" (50,0 mm) Wide
98-101	2.62" (66,5 mm) Wide
102	2.95" (75,0 mm) Wide
103	3.94" (100,0 mm) Wide
104-107	5.00" (127,0 mm) Wide
108-110	6.00" (152,4 mm) Wide
111-114	Performance Curves

Crossed Roller Bearing Positioners

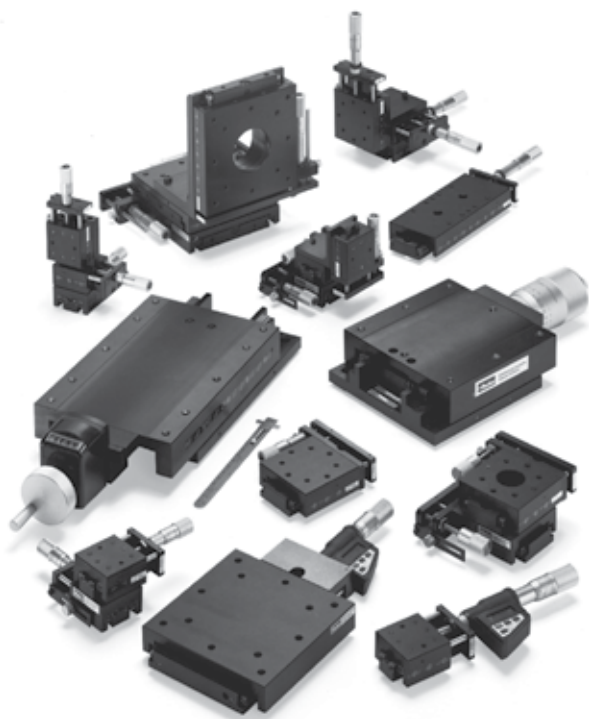

- Precision Quality
- Budget Friendly
- Largest Selection
- Easy multi-axis configuration
- No maintenance
- Vacuum preparation and custom options

Crossed Roller Positioner Design Principles

Crossed roller positioning stages offer exceptional load carrying capability, approximately 2 to 2 1/2 times that of comparably sized ball bearing stages. Additionally, crossed roller stages provide up to five times the life expectancy of the ball bearing stages without degradation of performance. Parker crossed roller stages are rated for over 100 million inches of travel at specified load. Three types of drive mechanisms are available: a fine screw, a micrometer, and a differential screw. The fine screw is used for fine resolution positioning. The micrometer is used whenever a position readout is required. The differential screw is used for applications requiring extremely fine resolution positioning. Crossed roller positioning stages are available in a straight stage/drive configuration as well as a side-drive configuration.

The linear positioner operates in a simple manner: a bracket which supports the drive screw is attached to the slide base. The end of the drive screw rests against the end of the moveable top. There are two extended springs “pulling” the slide top toward the screw so that the top will always be held firmly against the screw end. When the screw is turned clockwise, it advances and pushes the slide top along the linear axis. When turned counter clockwise, the screw retracts and the slide top follows because of the spring pressure holding the top against the screw end. The result is a very smooth linear motion, accurately controlled by rotation of the drive mechanism.

Standard Features

Exact manufacturing techniques, combined with demanding quality control standards, permit Parker Daedal to offer precision stages of unsurpassed quality. Selection can be made easily, based on required travel, load, and mounting surface requirements. Stages are available in single or multi-axis configurations (XY, XZ, and XYZ), and all have built-in quality features including:

- Aluminum/steel construction
- Low friction linear adjustment with no backlash or side play
- Factory preloaded to provide dynamic stability and minimum runout
- Both top and bottom mounting surfaces are precision machined to provide micro-flat mounting surfaces
- Locking screw to positively lock stage without affecting position
- Straight line accuracy of 0.00008 in/in of travel
- Selectable drive mechanisms: Micrometer (Imperial or metric), Fine screw (64 pitch), Differential screw, Digital micrometers (Imperial and Metric)

Digital Micrometers

The 1.0” (25 mm) travel micrometer provides an LCD readout to 0.00005 in (0,001 mm) resolution and features incremental and/or absolute positioning modes and automatic shutdown to conserve the integral battery. The battery will power the unit for 500 hours of use. The 2.0” (51 mm) micrometer is accurate to ± 0.0001 in (± 2 microns) with a resolution and LCD reading to 0.00005 in (1 micron). The batteries will power the unit up to 5,000 hours.

How to Order

Use the overview chart on the following page to select the appropriate crossed roller positioner. Refer to the individual specifications page for complete performance and mechanical specifications. To order crossed roller bearing positioners, use the model number corresponding to the specific size and travel length selected. A variety of modifications to standard models are available to meet custom requirements. Contact our application engineering department with your design specifications.

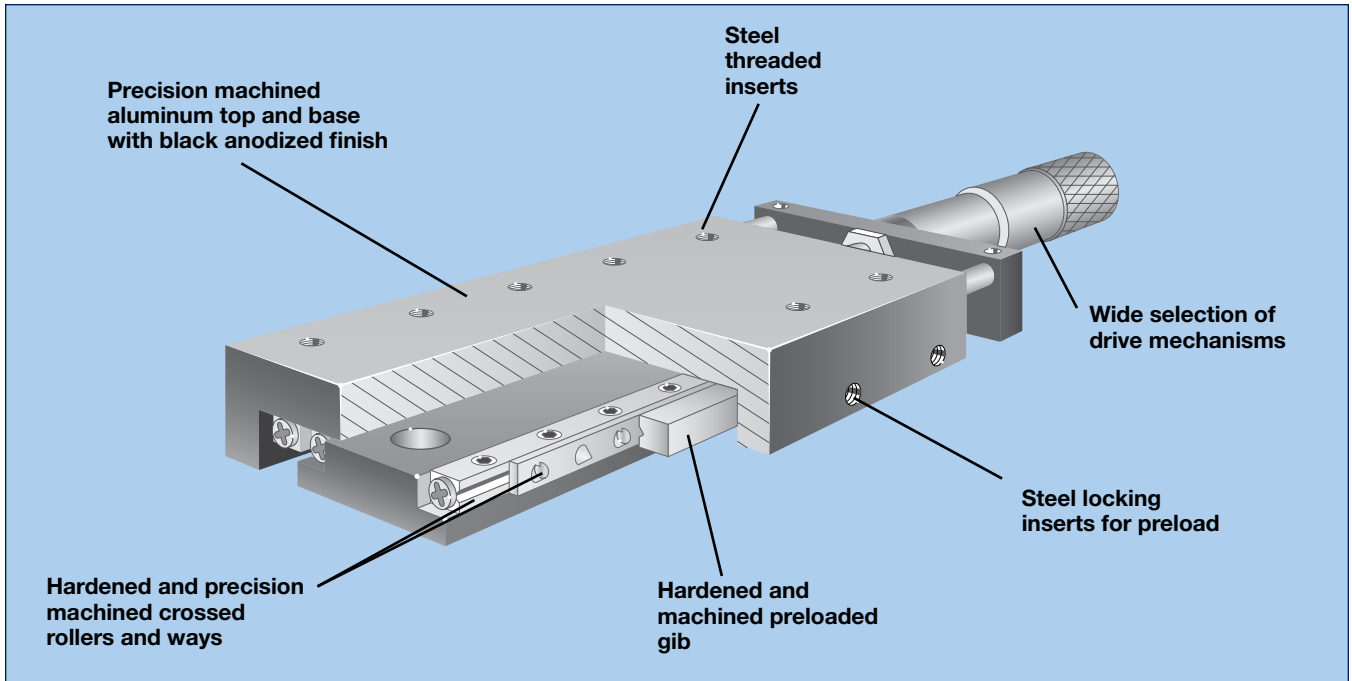

Crossed Roller Positioners

Series	Width in (mm)	Travel		Normal Load		Drive Orientation		Mounting		Page
		in	(mm)	lbs	(kg)	Center	Side	Imperial	Metric	
CR4000	1.75 (44,5)	1.00	(25,4)	81	(37)	•	•	•		92-94
CR4100				81	(37)	•	•	•		95-96
CR4200				121	(55)	•	•	•		95-96
CR4300				131	(59)	•	•	•		95-96
SC050	1.97 (50,0)	0.98	(25)	175	(80)	•		•		97
SK050		1.97	(50)	263	(119)	•		•		
		2.95	(75)	351	(159)	•		•		
CR4500	2.62 (66,5)	1.00	(25,4)	111	(50)	•	•	•		98-99, 101
CR4600				151	(69)	•	•	•		100-101
CR4700				201	(91)	•	•	•		100-101
CR4800				251	(114)	•	•	•		100-101
SC075	2.95 (75,0)	0.98	(25)	351	(159)	•		•		102
SK075		1.97	(50)	439	(199)	•		•		
		2.95	(75)	527	(239)	•		•		
SC100	3.94 (100,0)	0.98	(25)	439	(199)	•		•		103
SK100		1.97	(50)	527	(239)	•		•		
		2.95	(75)	614	(278)	•		•		
		3.94	(100)	702	(318)	•		•		
CR4400	5.0 (127,0)	1.00	(25,4)	201	(91)	•	•	•		104-107
		2.00	(50,8)	201	(91)	•	•	•		104-107
CR4900	6.0 (152,4)	1.00	(50,8)	423	(192)	•		•		108-109
		2.00	(50,8)	423	(192)	•		•		108-109
		4.00	(100,0)	423	(192)	•		•		110
		6.00	(150,0)	719	(326)	•		•		110
		8.00	(200,0)	1052	(477)	•		•		110
		10.00	(250,0)	1395	(633)	•		•		110
	12.00	(300,0)	1735	(786)	•		•		110	

CR4000 Series

Specifications	
Travel:	0.5 in
Size:	
Width	1.75 in
Length (mid-travel)	2.95 – 4.47 in
Height	1.00 in
Load:	
Normal	81 lbs
Thrust – T _a	10 lbs
Thrust – T _b	5 lbs
Moment – Yaw, Pitch, Roll	See page 111
Straight line accuracy:	0.00008 in/in of travel
Micrometer graduations:	0.001 in or 0,01 mm
Differential screw:	
Coarse Adjustment	48 pitch
Fine Adjustment	336 pitch
Weight:	0.5 lbs/axis
Z-Axis bracket options: (See page 124-127)	
Center drive low profile	4009
Center drive standard	4010
Side drive low profile	4059
Side drive standard	4060
Construction:	Aluminum top and base/ steel crossed roller bearings
Mounting surface:	Precision machined
Finish:	Black anodize



Drive Mechanism	Travel	Center Drive Models				Side Drive Models			
		Single Axis	Two Axis	X-Y-Z Low Profile	X-Y-Z Standard	Single Axis	Two Axis	X-Y-Z Low Profile	X-Y-Z Standard
Imperial Micrometer	0.50 in	CR4002	CR4022	CR4032	CR4042	CR4052	CR4072	CR4082	CR4092
Metric Micrometer	13 mm	CR4002M	CR4022M	CR4032M	CR4042M	CR4052M	CR4072M	CR4082M	CR4092M
Differential Screw	2/8 mm	CR4002D	CR4022D	CR4032D	CR4042D	CR4052D	CR4072D	CR4082D	CR4092D



Dimensions Inches

For additional end view dimensions, refer to the CR4000 crossed roller slide drawing, page 40. Consult factory for critical dimension concerns.

Center Drive

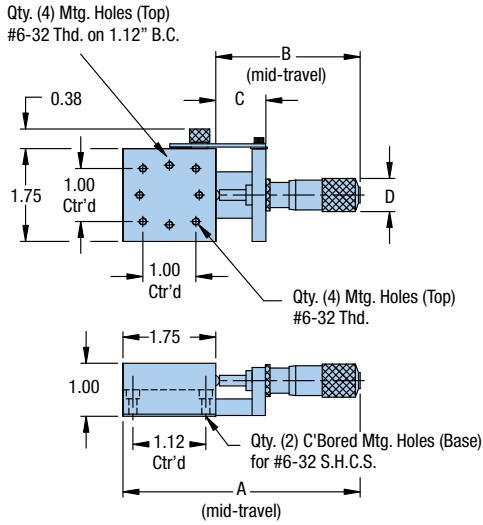

Single-Axis

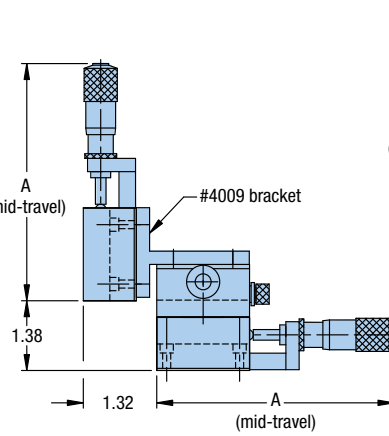

X-Y-Z Low-Profile

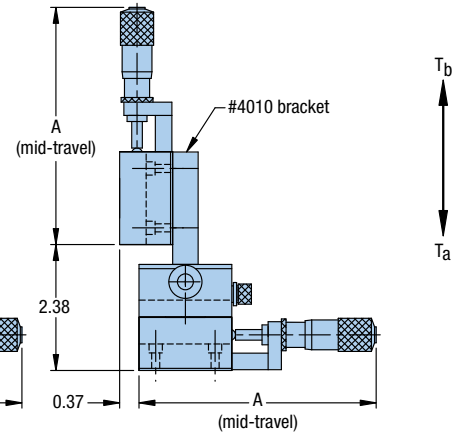

X-Y-Z Standard

Side Drive

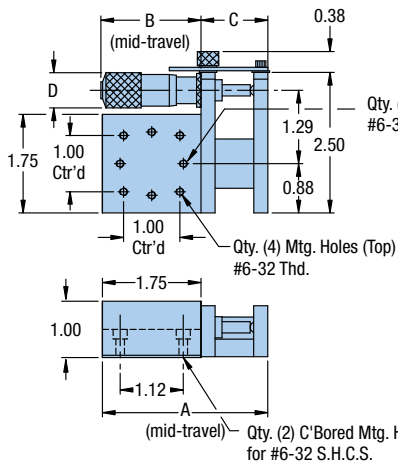

Single-Axis

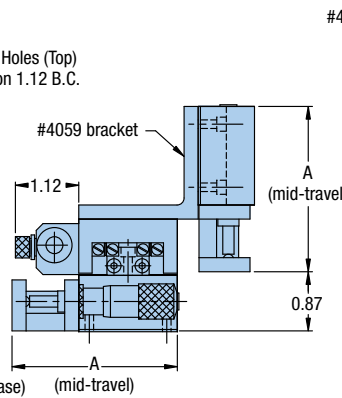

X-Y-Z Low-Profile

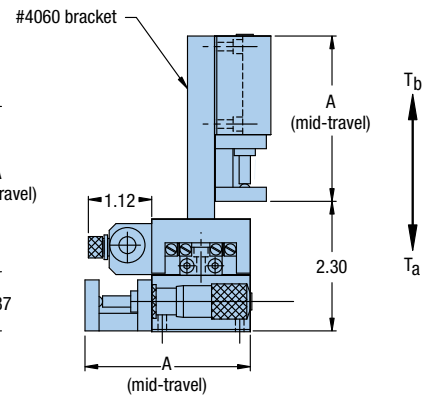

X-Y-Z Standard

Drive Mechanism	Travel	Center Drive Dimensions – in				Side Drive Dimensions – in			
		A	B	C	D	A	B	C	D
Imperial Micrometer	0.50 in	4.47	2.72	0.95	0.54	2.95	1.77	1.20	0.54
Metric Micrometer	13 mm	4.37	2.68	0.95	0.54	2.95	1.78	1.19	0.54
Differential Screw	2/8 mm	4.13	2.38	0.95	0.62	2.95	1.44	1.20	0.62

CR4000-DM Series

Specifications	
Travel:	1.0 in
Size:	
Width	1.75 in
Length (mid-travel)	7.75 in
Height	1.00 in
Load:	
Normal	81 lbs
Thrust – T_a	10 lbs
Thrust – T_b	3 lbs
Moment – Yaw, Pitch, Roll	See page 111
Straight line accuracy:	0.00008 in/in of travel
Micrometer graduations:	0.00005 in
Weight:	0.8 lbs
Construction:	Aluminum top and base/ 440C stainless steel bearings
Mounting surface:	Precision machined
Finish:	Black anodize

For additional end view dimensions, refer to the CR4000 crossed roller slide drawing, page 40. Consult factory for critical dimension concerns.



Dimensions Inches

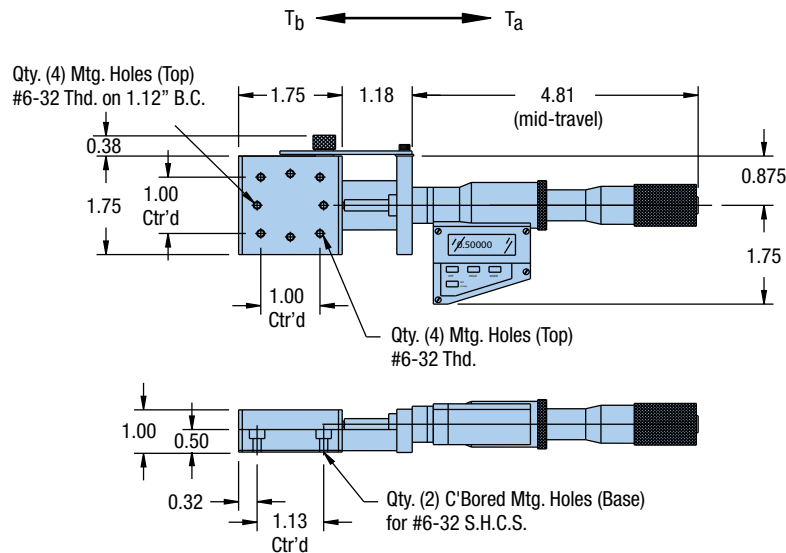

Model	
Imperial Mounting	CR4002-DM



CR4100, CR4200, CR4300 Series

Specifications	
Travel:	0.5 – 1.0 in
Size:	
Width	1.75 in
Length (mid-travel)	4.6 – 8.28 in
Height	0.75 in
Load:	
Normal	81 - 131 lbs
Thrust – T_a	10 lbs
Thrust – T_b	3 lbs
Moment – Yaw, Pitch, Roll	See page 111
Straight line accuracy:	0.00008 in/in of travel
Micrometer graduations:	0.001 in or 0,01 mm
Fine screw:	64 pitch
Weight:	0.8 – 1.3 lbs/axis
Construction:	Aluminum top and base/ steel crossed roller bearings
Mounting surface:	Precision machined
Finish:	Black anodize



Consult factory for critical dimension concerns.

Dimensions Inches

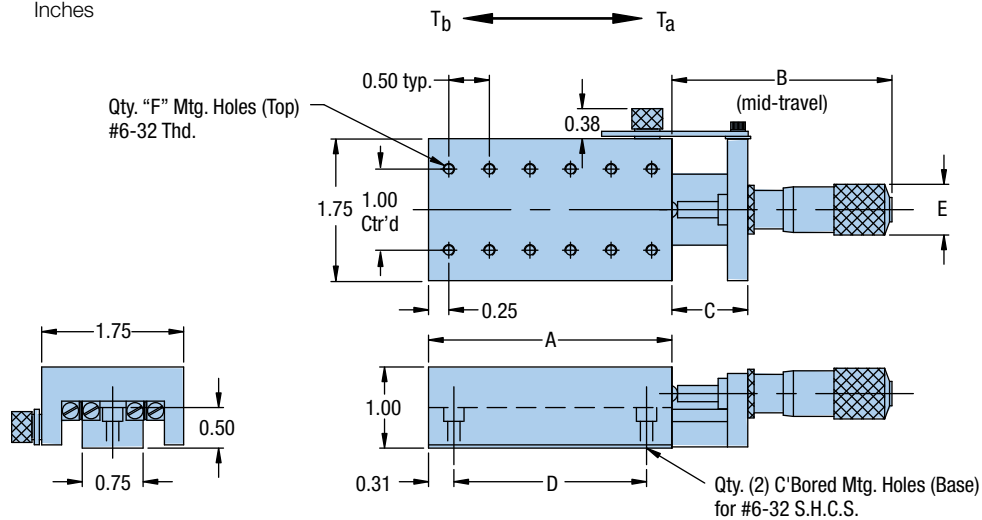

Drive Mechanism	Travel	Model	Load	Weight	Dimensions - in					Qty F
					A	B	C	D	E	
Imperial Micrometer	0.50 in	CR4102	81 lbs	0.5 lbs	2.00	2.72	0.94	1.38	0.55	8
	1.0 in	CR4104				4.28	1.18		0.71	
Metric Micrometer	13 mm	CR4102M	81 lbs	0.5 lbs	2.00	2.72	0.94	1.38	0.55	8
	25 mm	CR4104M				4.28	1.18		0.71	
Fine Screw	0.75 in	CR4103				2.50	0.94		0.58	
Imperial Micrometer	0.50 in	CR4202	121 lbs	0.8 lbs	3.00	2.72	0.94	2.38	0.55	12
	1.0 in	CR4204				4.28	1.18		0.71	
Metric Micrometer	13 mm	CR4202M	121 lbs	0.8 lbs	3.00	2.72	0.94	2.38	0.55	12
	25 mm	CR4204M				4.28	1.18		0.71	
Fine Screw	0.75 in	CR4203				2.50	0.94		0.58	
Imperial Micrometer	0.50 in	CR4302	131 lbs	1.0 lbs	4.00	2.72	0.94	3.38	0.55	16
	1.0 in	CR4304				4.28	1.18		0.71	
Metric Micrometer	13 mm	CR4302M	131 lbs	1.0 lbs	4.00	2.72	0.94	3.38	0.55	16
	25 mm	CR4304M				4.28	1.18		0.71	
Fine Screw	0.75 in	CR4303				2.50	0.94		0.58	

Crossed Roller Positioners

CR4100-DM, CR4200-DM, CR4300-DM Series

Specifications	
Travel:	1.0 in
Size:	
Width	1.75 in
Length (mid-travel)	7.99 – 9.99 in
Height	1.00 in
Load:	
Normal	81 – 131 lbs
Thrust – T_a	10 lbs
Thrust – T_b	3 lbs
Moment – Yaw, Pitch, Roll	See page 111
Straight line accuracy:	0.00008 in/in of travel
Micrometer graduations:	0.00005 in
Weight:	0.9 – 1.3 lbs/axis
Construction:	Aluminum top and base/ 440C stainless steel bearings
Mounting surface:	Precision machined
Finish:	Black anodize



Consult factory for critical dimension concerns.

Dimensions Inches

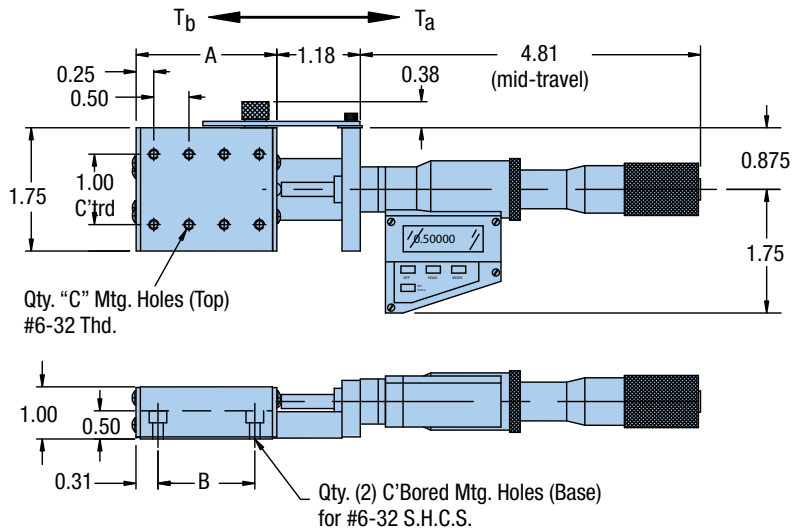

Model	Normal Load	Weight	Dimensions – in		
			A	B	C
CR4104-DM	81 lbs	1.0 lbs	2.00	1.38	8
CR4204-DM	121 lbs	1.1 lbs	3.00	2.38	12
CR4304-DM	131 lbs	1.3 lbs	4.00	3.38	16



SC050/SK050 Series

Specifications

Travel:	0.98 – 2.95 in (25 – 75 mm)
Size:	
Width	1.97 in (50,0 mm)
Length	5.55 – 10.04 in (141,0,0 – 255,0 mm)
Height	0.98 in (25,0 mm)
Load:	
Normal	175 – 351 lbs (80 – 159 kg)
Moment: Yaw, Pitch, Roll	See page 112
Straight line accuracy:	0.00008 in/in of travel 2 µm/25 mm of travel
Weight:	0.9 – 2.0 lbs (0,4 – 0,9 kg)
Construction:	Aluminum top and base/ steel crossed roller bearings
Mounting surface:	Precision machined
Finish:	Black anodize

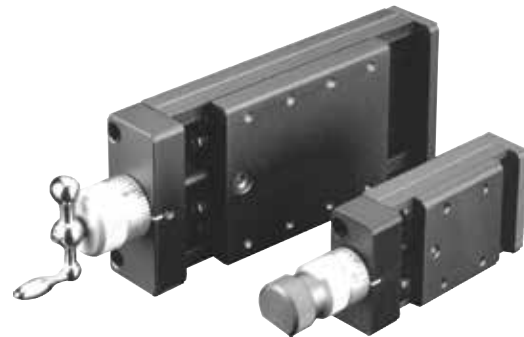

SC Crank Lead Screw (left); SK Knob Lead Screw (right)

Consult factory for critical dimension concerns.

Crossed Roller Positioners

Dimensions in (mm)

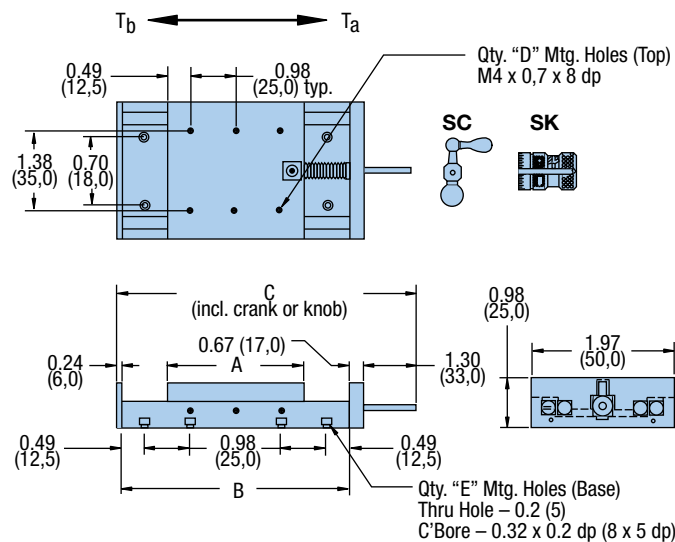

Model	Travel		Normal Load		Weight		Dimension – in (mm)			Qty D	Qty E			
	in (mm)		lbs (kg)		lbs (kg)		A	B	C					
SC050A-075 SK050A-075	0.98	(25)	175	(80)	0.9	(0,4)	1.97	(50,0)	2.95	(75,0)	5.55	(141,0)	4	6
SC050A-125 SK050A-125	1.97	(50)	263	(119)	1.4	(0,7)	2.95	(75,0)	4.92	(125,0)	8.07	(205,0)	6	8
SC050A-175 SK050A-175	2.95	(75)	351	(159)	2.0	(0,9)	3.94	(100,0)	6.89	(175,0)	10.04	(255,0)	8	8

CR4500 Series

Specifications	
Travel:	0.5 – 1.0 in
Size:	
Width	2.62 in
Length (mid-travel)	5.01 – 6.93 in
Height	1.00 in
Load:	
Normal	111 lbs
Thrust – T _a	10 lbs
Thrust – T _b	2 lbs
Moment – Yaw, Pitch, Roll	See page 111
Straight line accuracy:	0.00008 in/in of travel
Micrometer graduations:	0.001 in or 0,01 mm
Differential screw:	
Coarse Adjustment	48 pitch
Fine Adjustment	336 pitch
Fine screw:	64 pitch
Weight:	
Center drive	0.9 lbs/axis
Side drive	1.0 lbs/axis
Z-Axis bracket options: (See page 124-127)	
Center drive low profile	4509
Center drive standard	4510
Side drive low profile	4559
Side drive standard	4560
Construction:	Aluminum top and base/ steel crossed roller bearings
Mounting surface:	Precision machined
Finish:	Black anodize



Style	Drive Mechanism	Travel	Center Drive Models				Side Drive Models			
			Single Axis	Two Axis	X-Y-Z Low Profile	X-Y-Z Standard	Single Axis	Two Axis	X-Y-Z Low Profile	X-Y-Z Standard
Solid Top	Imperial	0.50 in	CR4502	CR4522	CR4532	CR4542	CR4552	CR4572	CR4582	CR4592
	Micrometer	1.0 in	CR4504	CR4524	CR4534	CR4544	CR4554	CR4574	CR4584	CR4594
	Metric Micrometer	13 mm	CR4502M	CR4522M	CR4532M	CR4542M	CR4552M	CR4572M	CR4582M	CR4592M
	Differential Screw	25 mm	CR4504M	CR4524M	CR4534M	CR4544M	CR4554M	CR4574M	CR4584M	CR4594M
	Fine Screw	0.08/0.3 in	CR4502D	CR4522D	CR4532D	CR4542D	CR4552D	CR4572D	CR4582D	CR4592D
			0.75 in	CR4503	CR4523	CR4533	CR4543	CR4553	CR4573	CR4583
Aperture (1.0 in)	Imperial	0.50 in	CR4506	CR4526	CR4536	CR4546	CR4556	CR4576	CR4586	CR4596
	Micrometer	13 mm	CR4506M	CR4526M	CR4536M	CR4546M	CR4556M	CR4576M	CR4586M	CR4596M
	Metric Micrometer	0.08/0.3 in	CR4506D	CR4526D	CR4536D	CR4546D	CR4556D	CR4576D	CR4586D	CR4596D
	Differential Screw									
	Fine Screw	0.75 in	CR4507	CR4527	CR4537	CR4547	CR4557	CR4577	CR4587	CR4597



Dimensions Inches

For additional end view dimensions, refer to the CR4500 crossed roller slide drawing, page 44. Consult factory for critical dimension concerns.

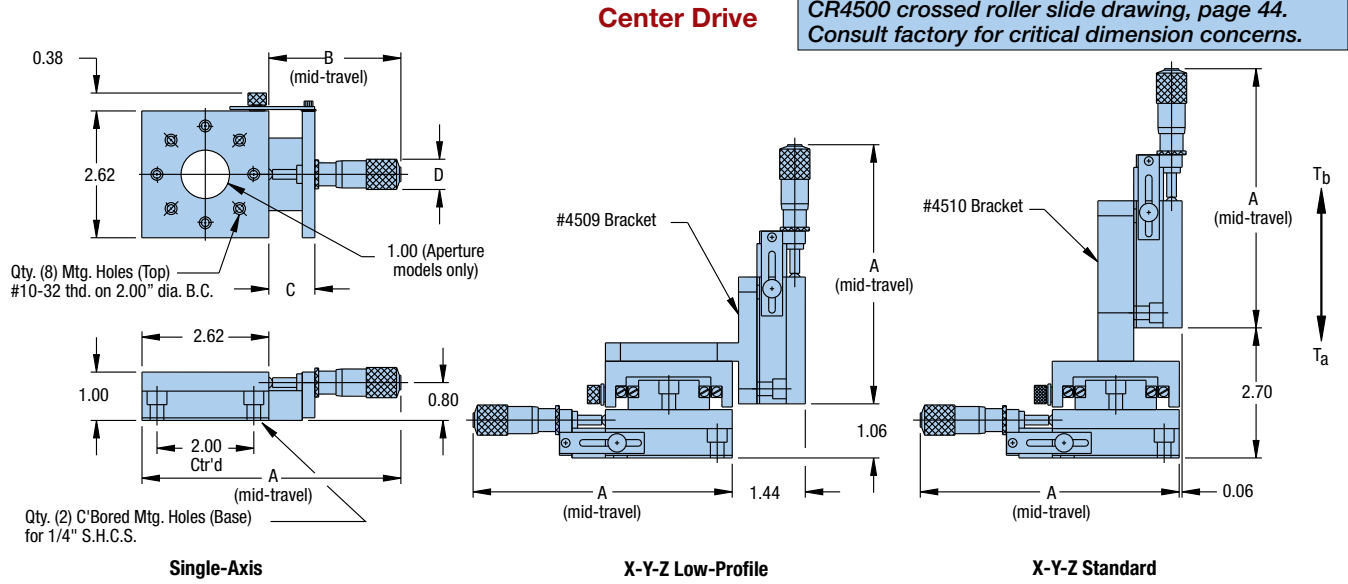

Side Drive

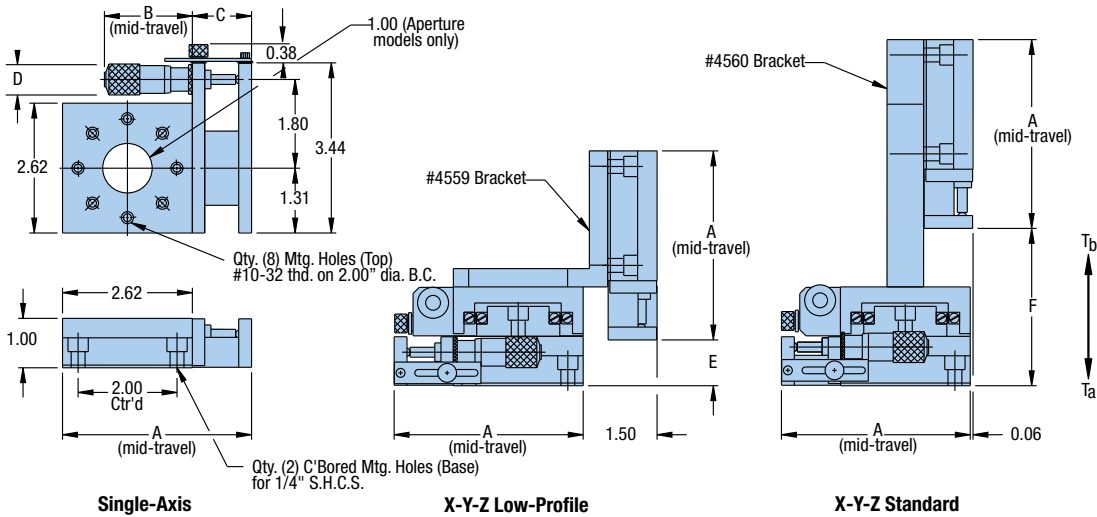

Style	Drive Mechanism		Center Drive Dimensions – in				Side Drive Dimensions – in					
			A	B	C	D	A	B	C	D	E	F
Solid Top	Imperial Micrometer	0.50 in	5.35	2.73	0.95	0.54	3.82	1.78	1.20	0.54	0.93	3.18
		1.0 in	6.93	4.31	1.22	0.71	4.07	3.10	1.45	0.71	0.68	2.93
	Metric Micrometer	13 mm	5.35	2.73	0.95	0.54	3.82	1.78	1.20	0.54	0.93	3.18
		25 mm	6.93	4.31	1.22	0.71	4.07	3.10	1.45	0.71	0.68	2.93
Aperture (1.0 in)	Differential Screw	0.08/0.3 in	5.01	2.39	0.95	0.62	3.82	1.44	1.20	0.62	0.93	3.18
		Fine Screw	0.75 in	5.24	2.62	0.95	0.58	3.82	1.72	1.20	0.58	0.93
Aperture (1.0 in)	Imperial Micrometer	0.50 in	5.35	2.73	0.95	0.54	3.82	1.78	1.20	0.54	0.93	3.18
		Metric Micrometer	13 mm	5.35	2.73	0.95	0.54	3.82	1.78	1.20	0.54	0.93
	Differential Screw	0.08/0.3 in	5.01	2.39	0.95	0.62	3.82	1.44	1.20	0.62	0.93	3.18
		Fine Screw	0.75 in	5.24	2.62	0.95	0.58	3.82	1.72	1.20	0.58	0.93

CR4600, CR4700, CR4800 Series

For additional end view dimensions, refer to the CR4600-4800 crossed roller slide drawing, page 45. Consult factory for critical dimension concerns.

Specifications	
Travel:	0.5 – 1.0 in
Size:	
Width	2.62 in
Length (mid-travel)	6.62 – 10.31 in
Height	1.00 in
Load:	
Normal	151 – 252 lbs
Thrust – T _a	30 lbs
Thrust – T _b	2 lbs
Moment – Yaw, Pitch, Roll	See page 111
Straight line accuracy:	0.00008 in/in of travel
Micrometer graduations:	0.001 in or 0,01 mm
Fine screw:	64 pitch
Weight:	1.1 – 1.5 lbs/axis
Construction:	Aluminum top and base/ steel crossed roller bearings
Mounting surface:	Precision machined
Finish:	Black anodize

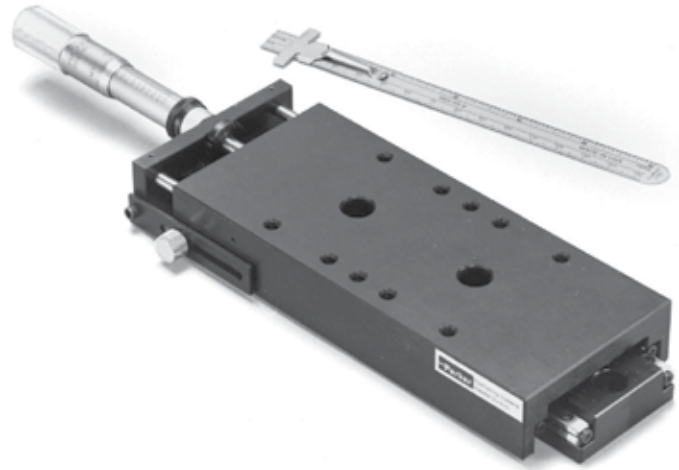

Dimensions Inches

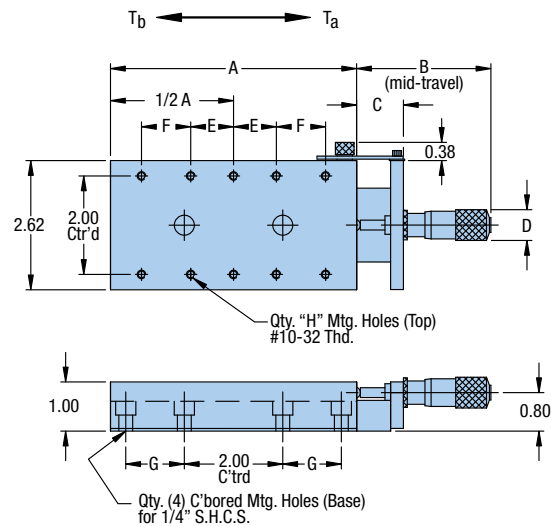

Drive Mechanism	Travel	Model	Load	Weight	Dimensions - in								
					A	B	C	D	E	F	G	H	
Imperial Micrometer	0.50 in	CR4602	151 lbs	1.1 lbs	4.00	2.73	2.73	0.95	0.54	0.50	—	0.69	6
	1.0 in	CR4604				4.31	4.31	1.22	0.71				
Metric Micrometer	13 mm	CR4602M	151 lbs	1.1 lbs	4.00	2.73	2.73	0.95	0.54	0.50	—	0.69	6
	25 mm	CR4604M				4.31	4.31	1.22	0.71				
Fine Screw	0.75 in	CR4603				2.62	2.62	0.95	0.58				
Imperial Micrometer	0.50 in	CR4702	201 lbs	1.3 lbs	5.00	2.73	2.73	0.95	0.54	1.00	—	1.19	6
	1.0 in	CR4704				4.31	4.31	1.22	0.71				
Metric Micrometer	13 mm	CR4702M	201 lbs	1.3 lbs	5.00	2.73	2.73	0.95	0.54	1.00	—	1.19	6
	25 mm	CR4704M				4.31	4.31	1.22	0.71				
Fine Screw	0.75 in	CR4703				2.62	2.62	0.95	0.58				
Imperial Micrometer	0.50 in	CR4802	252 lbs	1.5 lbs	6.00	2.73	2.73	0.95	0.54	0.50	1.00	1.69	10
	1.0 in	CR4804				4.31	4.31	1.22	0.71				
Metric Micrometer	13 mm	CR4802M	252 lbs	1.5 lbs	6.00	2.73	2.73	0.95	0.54	0.50	1.00	1.69	10
	25 mm	CR4804M				4.31	4.31	1.22	0.71				
Fine Screw	0.75 in	CR4803				2.62	2.62	0.95	0.58				



CR4500-DM Series
CR4600-DM, CR4700-DM, CR4800-DM Series

For additional end view dimensions, refer to the CR4500 and CR4600-4800 crossed roller slide drawing, page 44-45. Consult factory for critical dimension concerns.

Specifications	
Travel:	1.0 in
Size:	
Width	2.62 in
Length (mid-travel)	8.65 – 12.03 in
Height	1.00 in
Load:	
Normal Thrust – T_a	111 – 252 lbs
Thrust – T_b	10 lbs
Moment – Yaw, Pitch, Roll	2 lbs
	See page 111
Straight line accuracy:	0.00008 in/in of travel
Micrometer graduations:	0.00005 in or 0,001 mm
Weight:	1.5 – 2.1 lbs/axis
Construction:	Aluminum top and base/ steel crossed roller bearings
Mounting surface:	Precision machined
Finish:	Black anodize



Crossed Roller Positioners

Dimensions Inches

CR4500-DM

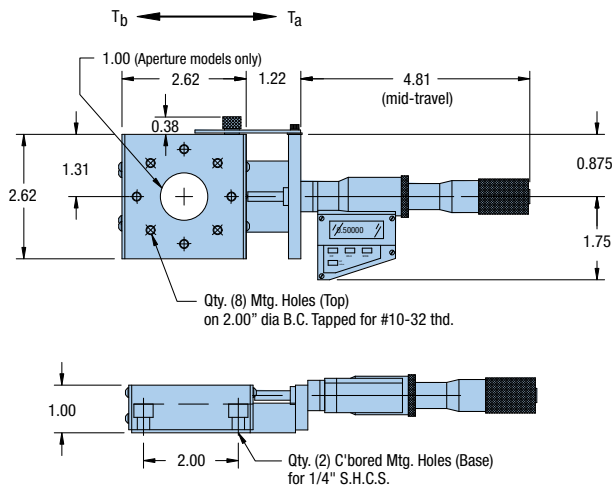

CR4600-DM – CR4800-DM

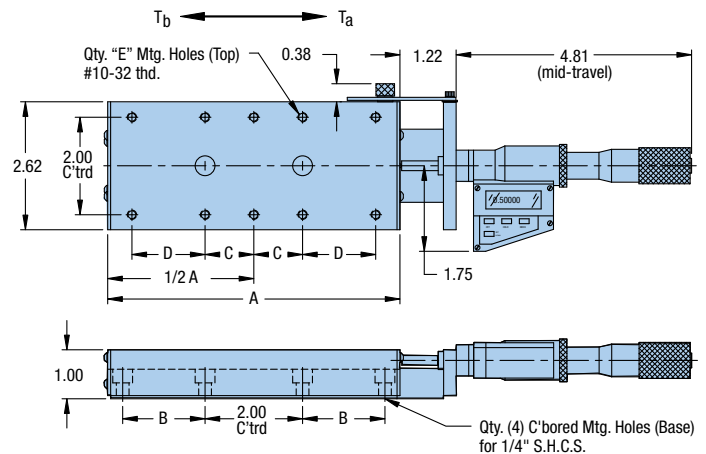

Model	Load	Weight	Dimensions - in				Qty E
			A	B	C	D	
CR4504-DM	111 lbs	1.5 lbs	—	—	—	—	—
CR4604-DM	151 lbs	1.7 lbs	4.00	0.69	0.50	—	6
CR4704-DM	201 lbs	1.9 lbs	5.00	1.19	1.00	—	6
CR4804-DM	252 lbs	2.1 lbs	6.00	1.69	0.50	1.00	10

SC075/SK075 Series

Specifications	
Travel:	0.98 – 2.95 in (25 – 75 mm)
Size:	
Width	2.95 in (75,0 mm)
Length	3.94 – 7.87 in (175,0 – 283,0 mm)
Height	1.26 in (32,0 mm)
Load:	
Normal	351 – 527 lbs (159 – 239 kg)
Moment: Yaw, Pitch, Roll	See page 112
Straight line accuracy:	0.00008 in/in of travel 2 µm/25 mm of travel
Weight:	1.7 – 3.5 lbs (0,8 – 1,6 kg)
Construction:	Aluminum top and base/ steel crossed roller bearings
Mounting surface:	Precision machined
Finish:	Black anodize



SC Crank Lead Screw (left); SK Knob Lead Screw (right)

Consult factory for critical dimension concerns.

Dimensions in (mm)

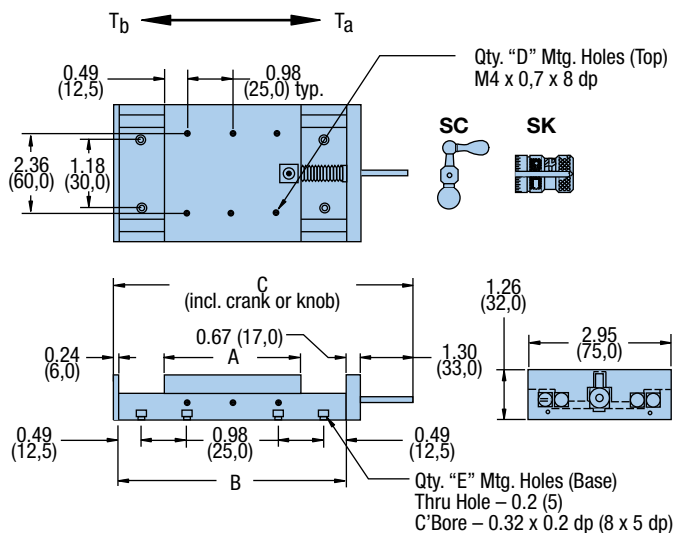

Model	Travel		Normal Load		Weight		Dimension – in (mm)			Qty D	Qty E			
	in (mm)	(mm)	lbs (kg)	(kg)	lbs (kg)	(kg)	A	B	C					
SC075A-100 SK075A-100	0.98	(25)	351	(159)	1.7	(0,8)	2.95	(75,0)	3.94	(100,0)	7.20	(183)	6	8
SC075A-150 SK075A-150	1.97	(50)	439	(199)	2.6	(1,2)	3.94	(100,0)	5.90	(150,0)	9.17	(233)	8	8
SC075A-200 SK075A-200	2.95	(75)	527	(239)	3.5	(1,6)	4.92	(125,0)	7.87	(200,0)	11.14	(283)	10	8



SC100/SK100 Series

Specifications

Travel:	0.98 – 3.94 in (25 – 100 mm)
Size:	
Width	3.94 in (100,0 mm)
Length	8.86 – 15.08 in (225,0 – 383,0 mm)
Height	1.45 in (37,0 mm)
Load:	
Normal	439 – 702 lbs (199 – 318 kg)
Moment: Yaw, Pitch, Roll	See page 113
Straight line accuracy:	0.00008 in/in of travel 2 µm/25 mm of travel
Weight:	3.7 – 7.3 lbs (1,7 – 3,4 kg)
Construction:	Aluminum top and base/ steel crossed roller bearings
Mounting surface:	Precision machined
Finish:	Black anodize

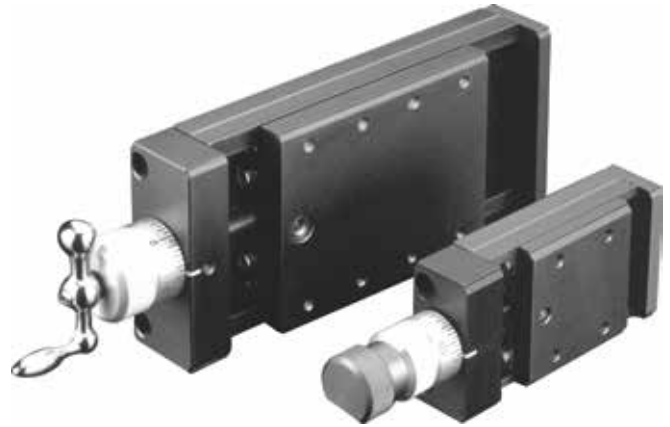

SC Crank Lead Screw (left); SK Knob Lead Screw (right)

Consult factory for critical dimension concerns.

Crossed Roller Positioners

Dimensions in (mm)

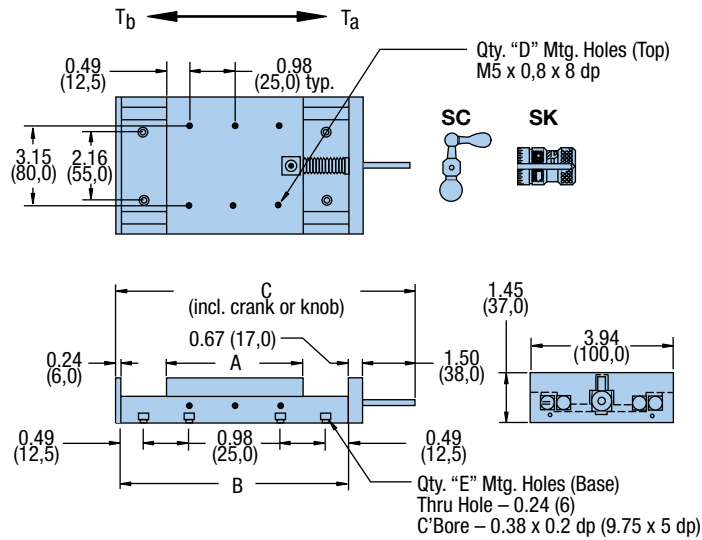

Model	Travel		Normal Load		Weight		Dimension – in (mm)			Qty D	Qty E			
	in (mm)		lbs (kg)		lbs (kg)		A	B	C					
SC100A-150 SK100A-150	0.98	(25)	439	(199)	3.7	(1,7)	4.92	(125,0)	5.90	(150,0)	9.17 8.86	(233) (225)	10	8
SC100A-200 SK100A-200	1.97	(50)	527	(239)	4.9	(2,2)	5.90	(150,0)	7.87	(200,0)	11.14 10.83	(283) (275)	12	8
SC100A-250 SK100A-250	2.95	(75)	614	(278)	6.1	(2,8)	6.89	(175,0)	9.84	(250,0)	13.11 12.80	(333) (325)	14	8
SC100A-300 SK100A-300	3.94	(100)	702	(318)	7.3	(3,4)	7.87	(200,0)	11.81	(300,0)	15.08 14.76	(383) (375)	16	8

CR4400 Series

Specifications	
Travel:	1.0 – 2.0 in
Size:	
Width	5.00 in
Length (mid-travel)	6.0 – 11.34 in
Height	1.00 in
Load:	
Normal	201 lbs
Thrust – T _a	30 lbs
Thrust – T _b	3 lbs
Moment – Yaw, Pitch, Roll	See page 114
Straight line accuracy:	0.00008 in/in of travel
Micrometer graduations:	0.001 in or 0,01 mm
Weight:	2.6 lbs/axis
Z-Axis bracket options: (See page 124-127)	4499
Construction:	Aluminum top and base/ steel crossed roller bearings
Mounting surface:	Precision machined
Finish:	Black anodize

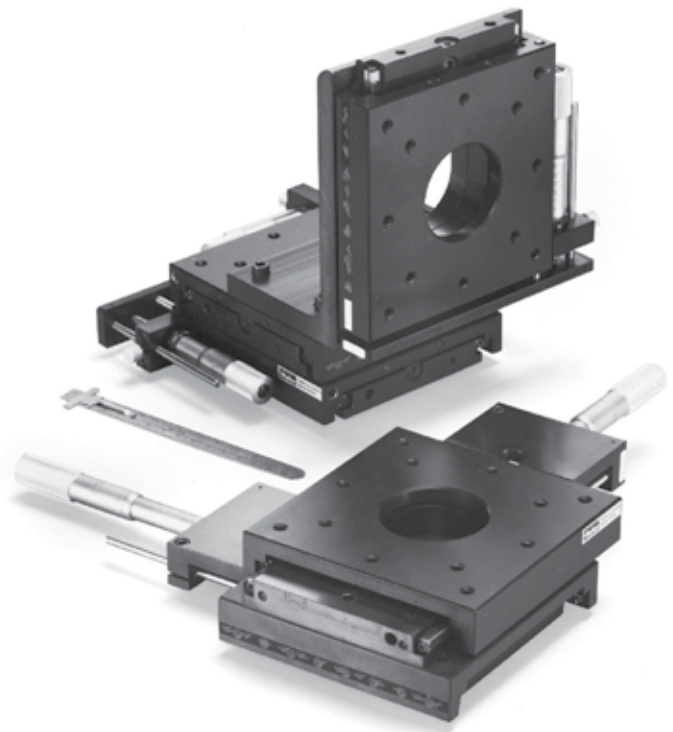

Style	Drive Mechanism	Travel	Center Drive Models			Side Drive Models		
			Single Axis	Two Axis	Three Axis	Single Axis	Two Axis	Three Axis
Solid Top	Imperial Micrometer	1.0 in	CR4411	CR4421	CR4431	CR4416	CR4426	CR4436
		2.0 in	CR4412	CR4422	CR4432	CR4417	CR4427	CR4437
	Metric Micrometer	25 mm	CR4413	CR4423	CR4433	CR4418	CR4428	CR4438
		50 mm	CR4414	CR4424	CR4434	CR4419	CR4429	CR4439
Aperture (2.0 in)	Imperial Micrometer	1.0 in	CR4451	CR4461	CR4471	CR4456	CR4466	CR4476
		2.0 in	CR4452	CR4462	CR4472	CR4457	CR4467	CR4477
	Metric Micrometer	25 mm	CR4453	CR4463	CR4473	CR4458	CR4468	CR4478
		50 mm	CR4454	CR4464	CR4474	CR4459	CR4469	CR4479



Dimensions Inches

For additional end view dimensions, refer to the CR4400 crossed roller slide drawing, page 50. Consult factory for critical dimension concerns.

Center Drive

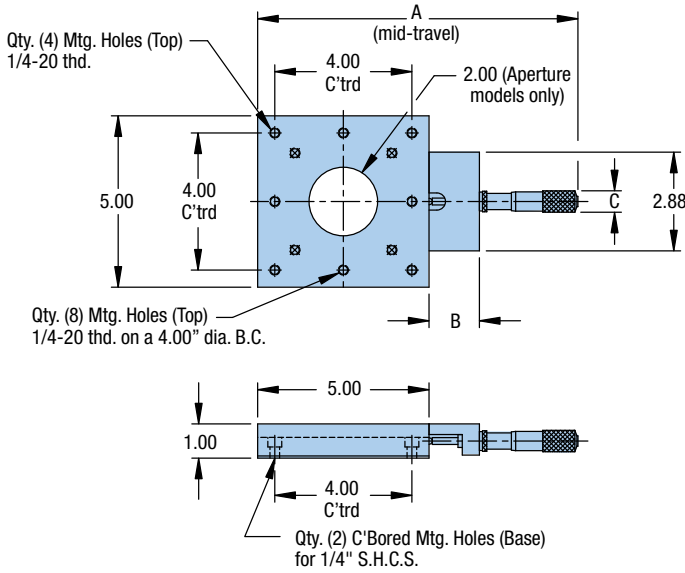

Single-Axis

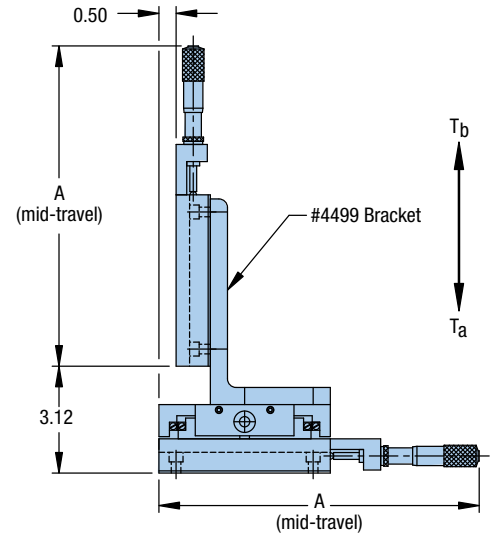

X-Y-Z Standard

Crossed Roller Positioners

Side Drive

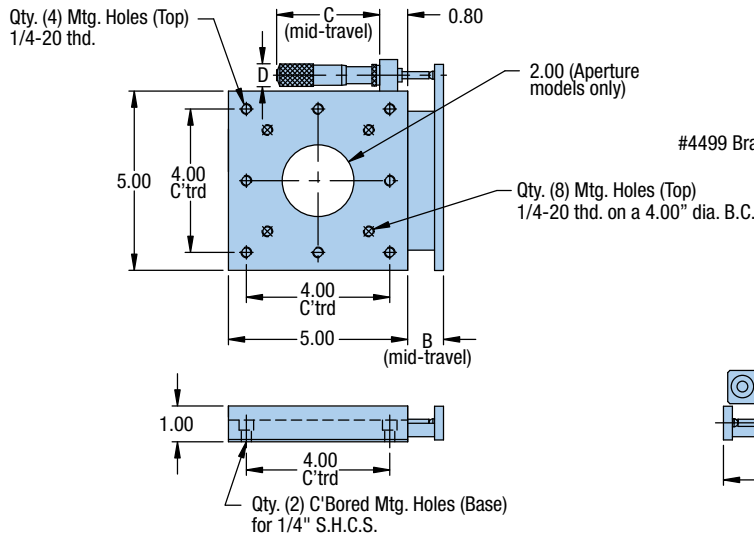

Single-Axis

X-Y-Z Standard

Style	Drive Mechanism	Travel	Center Drive Dimensions – in			Side Drive Dimensions – in			
			A	B	C	A	B	C	D
Solid Top	Imperial Micrometer	1.0 in	9.31	1.47	0.71	6.0	1.00	2.84	0.71
		2.0 in	11.34	1.98	0.73	6.5	1.50	4.36	0.73
	Metric Micrometer	25 mm	9.31	1.47	0.71	6.0	1.00	2.84	0.71
		50 mm	11.34	1.98	0.73	6.5	1.50	4.36	0.73
Aperture	Imperial Micrometer	1.0 in	9.31	1.47	0.71	6.0	1.00	2.84	0.71
		2.0 in	11.34	1.98	0.73	6.5	1.50	4.36	0.73
	Metric Micrometer	25 mm	9.31	1.47	0.71	6.0	1.00	2.84	0.71
		50 mm	11.34	1.98	0.73	6.5	1.50	4.36	0.73



CR4400-DM Series

Specifications	
Travel:	1.0 – 2.0 in
Size:	
Width	5.00 in
Length (mid-travel)	11.28 – 14.16 in
Height	1.00 in
Load:	
Normal	201 lbs
Thrust – T_a	30 lbs
Thrust – T_b	2.0 lbs
Moment – Yaw, Pitch, Roll	See page 114
Straight line accuracy:	0.00008 in/in of travel
Micrometer graduations:	0.00005 in or 0,001 mm
Weight:	3.1 lbs/axis
Construction:	Aluminum top and base/ steel crossed roller bearings
Mounting surface:	Precision machined
Finish:	Black anodize

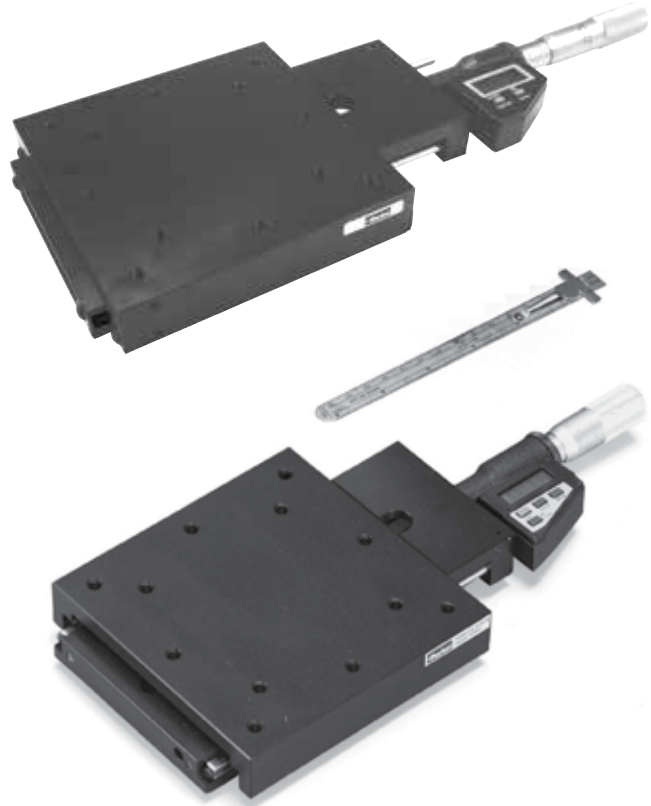

Series	Model	Travel
Solid Top	CR4411-DM	1.0 in
	CR4412-DM	2.0 in
Aperture (2.0 in)	CR4451-DM	1.0 in
	CR4452-DM	2.0 in



Dimensions Inches

For additional end view dimensions, refer to the CR4400 crossed roller slide drawing, page 50. Consult factory for critical dimension concerns.

1.0 in (25 mm) Travel Models

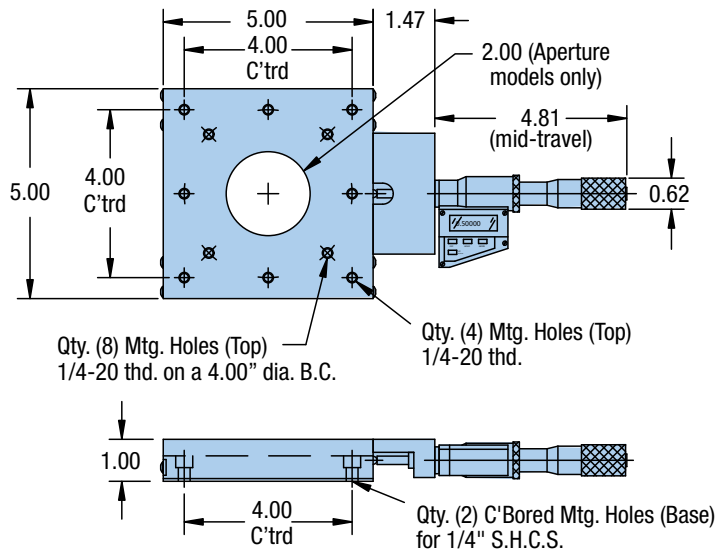

Crossed Roller Positioners

2.0 in (50 mm) Travel Models

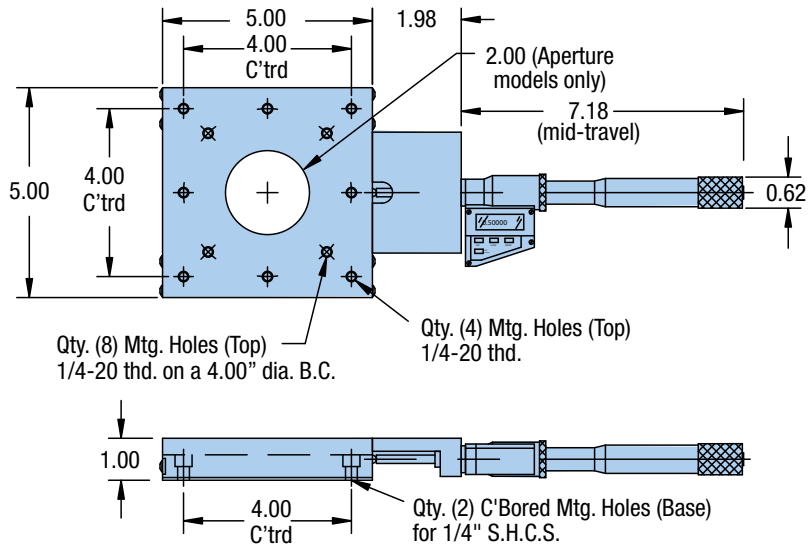

CR4900 Series

Specifications	
Travel:	1.0 – 2.0 in
Size:	
Width	6.00 in
Length (mid-travel)	9.59 – 11.94 in
Height	2.00 in
Load:	
Normal	423 lbs
Thrust T_a (Std. thimble)	30 lbs
Thrust T_b (Std. thimble)	5 lbs
Thrust T_a (Large thimble)	50 lbs
Thrust T_b (Large thimble)	5 lbs
Moment – Yaw, Pitch, Roll	See page 114
Straight line accuracy:	0.00008 in/in of travel
Micrometer graduations:	
Standard thimble	0.001 in or 0,01 mm
Large thimble	0.0001 in or 0,002 mm
Weight:	7 lbs/axis
Z-Axis bracket options: (See page 124-127)	4990-04
Construction:	Aluminum top and base/ steel crossed roller bearings
Mounting surface:	Precision machined
Finish:	Black anodize



Standard thimble with optional position lock (left), and large thimble (right). To order the optional lock, add -L to the model number selected from the chart below.

Consult factory for critical dimension concerns.

Dimensions Inches

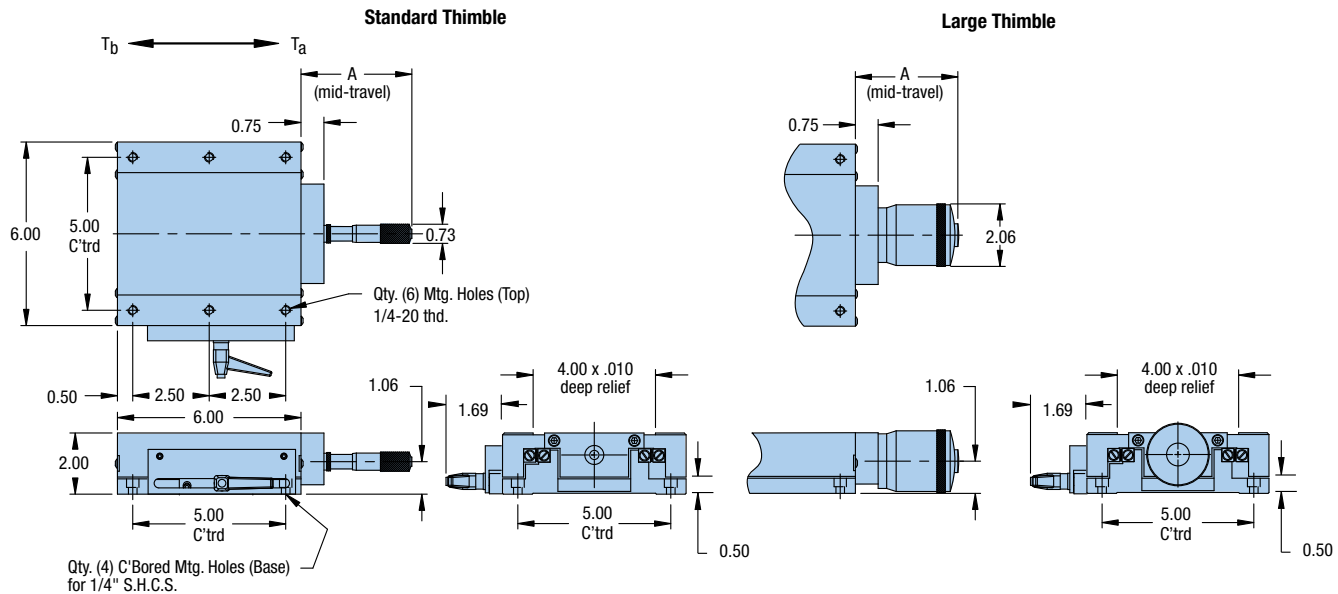

Drive Mechanism	Travel	Standard Thimble Size			Large Thimble Size		
		Model	Graduations	A – in	Model	Graduations	A – in
Imperial Micrometer	1.0 in	CR4914	0.001 in	3.59	CR4910	0.0001 in	4.44
	2.0 in	CR4915	0.001 in	5.11	CR4911	0.0001 in	5.94
Metric Micrometer	25 mm	CR4916	0.01 mm	3.59	CR4912	0.002 mm	4.44
	50 mm	CR4917	0.01 mm	5.11	CR4913	0.002 mm	5.94



CR4900-DM Series

Specifications

Travel:	2.0 in
Size:	
Width	6.00 in
Length (mid-travel)	13.93 in
Height	2.00 in
Load:	
Normal	423 lbs
Thrust T_a	50 lbs
Thrust - T_b	5 lbs
Moment - Yaw, Pitch, Roll	See page 114
Straight line accuracy:	0.00008 in/in of travel
Micrometer graduations:	
Large thimble	0.00005 in or 0,001 mm
Weight:	8 lbs/axis
Z-Axis bracket options: (See page 124-127)	4990-04
Construction:	Aluminum top and base/ steel crossed roller bearings
Mounting surface:	Precision machined
Finish:	Black anodize



Digital micrometer positioner shown with optional position lock. To order the optional lock, add -L to the model number selected from the chart below.

Consult factory for critical dimension concerns.

Crossed Roller Positioners

Dimensions Inches

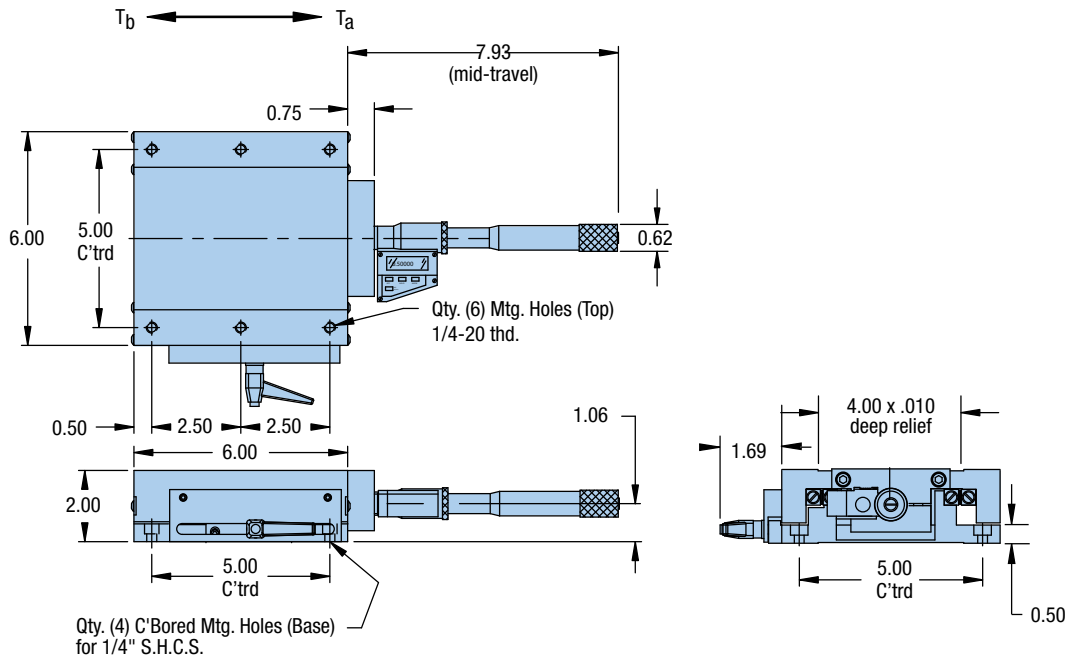

Model	
Imperial Mounting	CR4911-DM

CR4900 Series (Leadscrew Drive)

Specifications	
Travel:	4.0 – 12.0 in
Size:	
Width	6.00 in
Length (mid-travel)	10.04 – 23.04 in
Height	2.00 in
Load:	
Normal	423 – 1733 lbs
Thrust T_a	30 lbs
Thrust – T_b	30 lbs
Moment – Yaw, Pitch, Roll	See page 114
Straight line accuracy:	0.00008 in/in of travel
Readout graduations:	0.001 in or 0,01 mm
Weight:	4 – 12 lbs/axis
Z-Axis bracket options: (See page 124-127)	4990-04/-12
Construction:	Aluminum top and base/ steel crossed roller bearings
Mounting surface:	Precision machined
Finish:	Black anodize



Leadscrew drive positioner with readout (left); positioner with no readout and optional position lock (right). To order the optional lock, add -L to the model number selected from the chart below.

Consult factory for critical dimension concerns.

Dimensions Inches

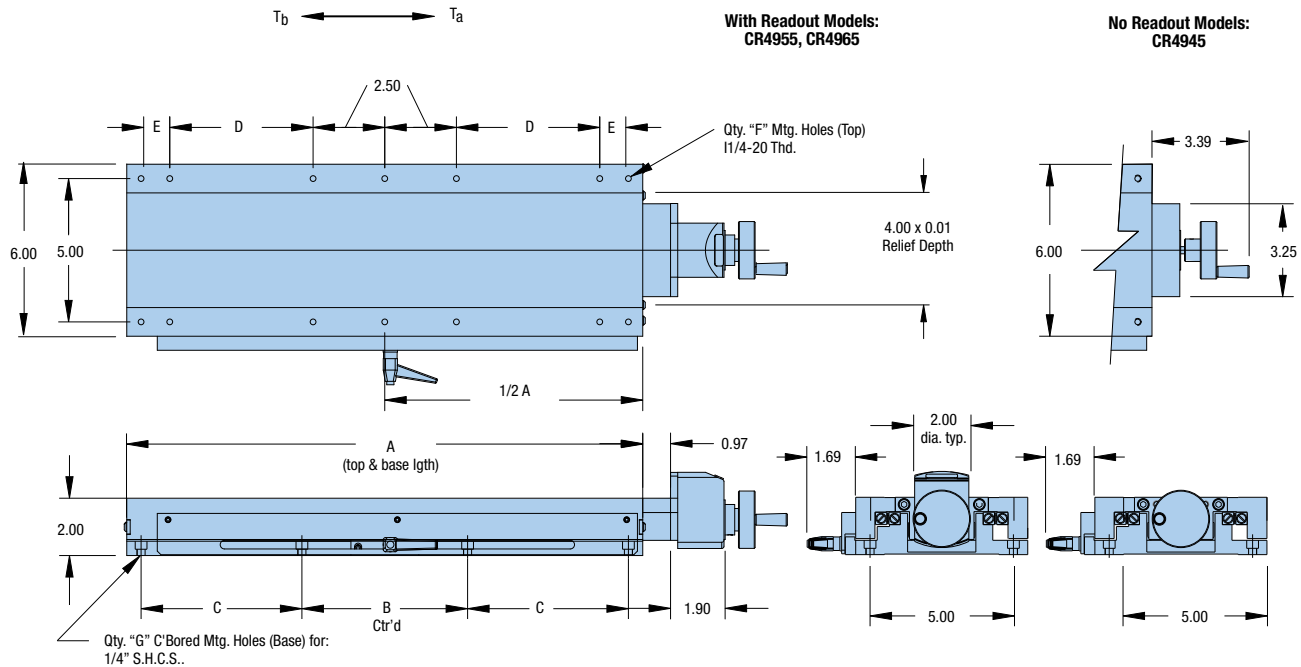

No Readout Model	Imperial Readout Model	Metric Readout Model	Travel	Load	Weight	Dimensions – In (mm)					Qty F	Qty G
						A	B	C	D	E		
CR4945-04	CR4955-04	CR4965-04	4.0 in	423 lbs	4.0 lbs	6.00	5.00	—	—	—	6	4
CR4945-06	CR4955-06	CR4965-06	6.0 in	719 lbs	6.0 lbs	9.00	5.00	1.50	1.50	—	10	8
CR4945-08	CR4955-08	CR4965-08	8.0 in	1052 lbs	8.0 lbs	12.00	5.00	3.00	2.50	—	10	8
CR4945-10	CR4955-10	CR4965-10	10.0 in	1395 lbs	10.0 lbs	15.00	6.00	4.00	2.50	2.00	14	8
CR4945-12	CR4955-12	CR4965-12	12.0 in	1735 lbs	12.0 lbs	18.00	7.00	5.00	5.00	1.00	14	8



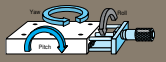

Crossed Roller Positioners

Yaw, Pitch, Roll

Yaw & Pitch Roll

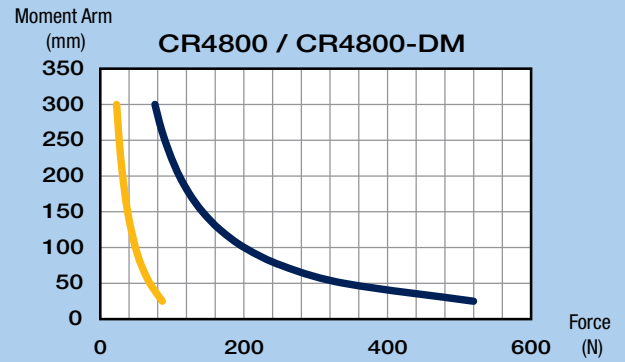
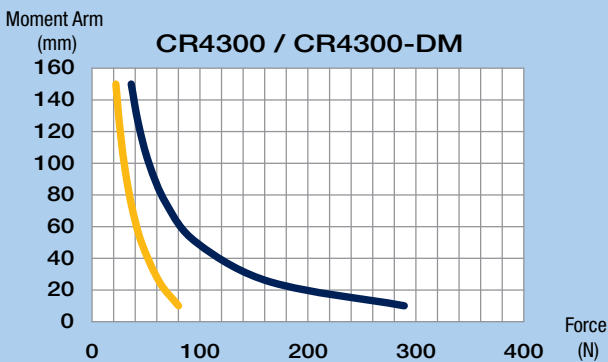
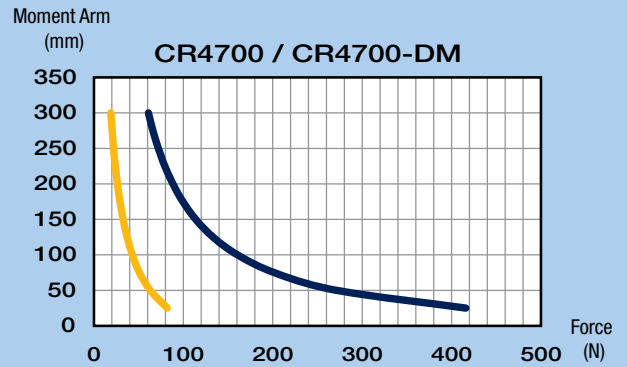
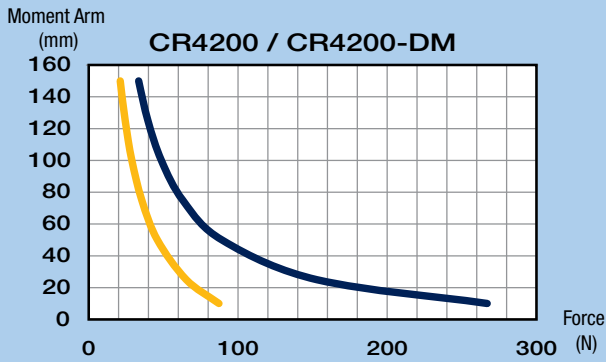
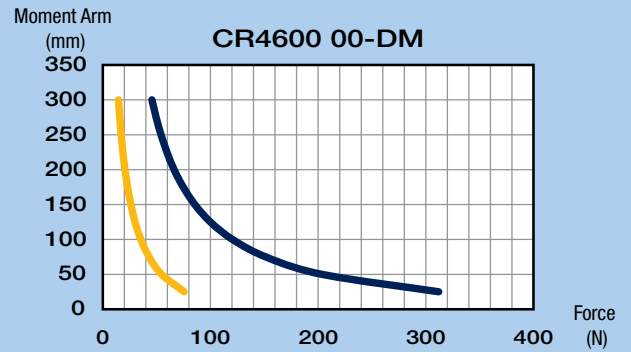
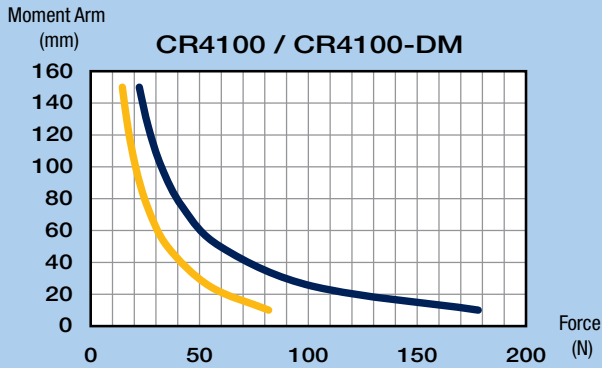
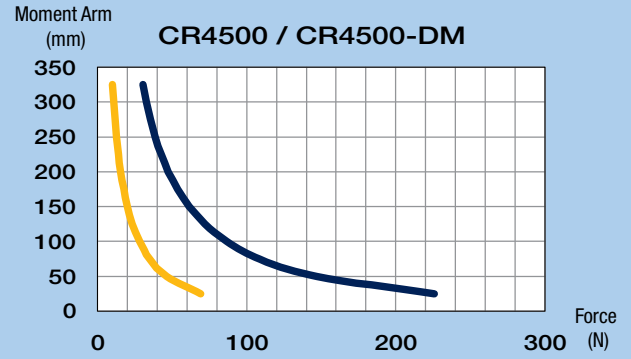
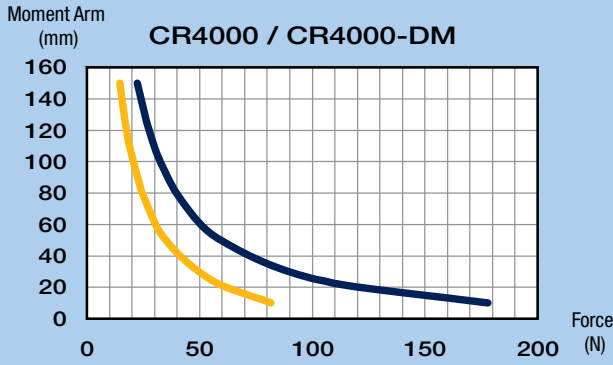

Yaw, Pitch, Roll

Yaw & Pitch **Roll**

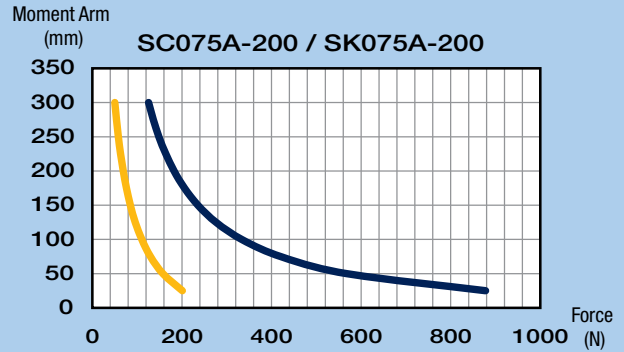
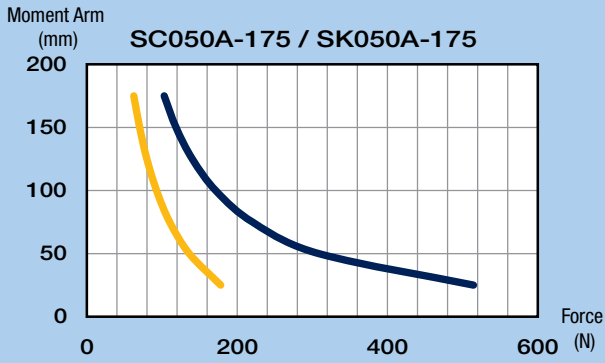
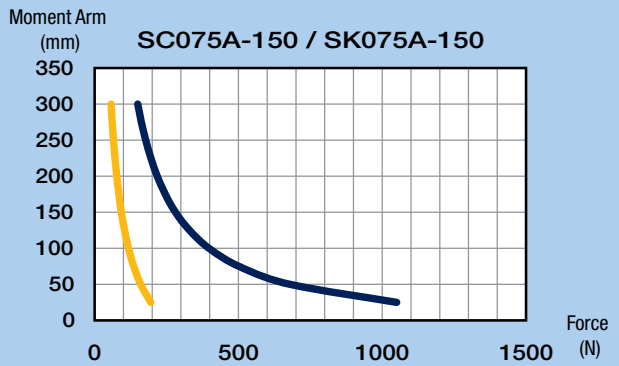
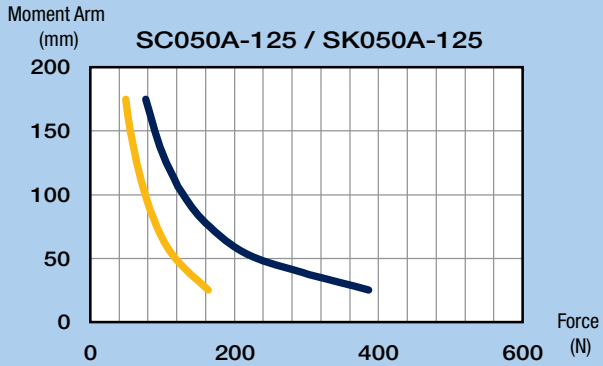
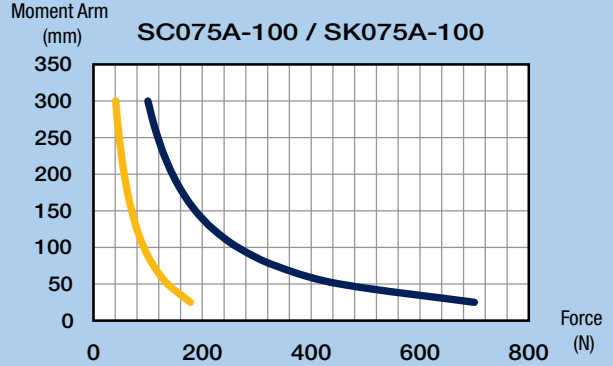
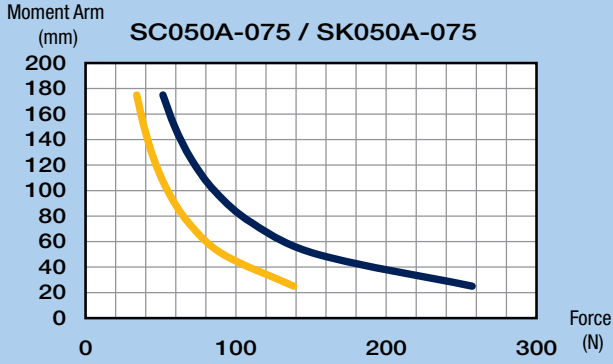

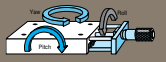

Yaw, Pitch, Roll

Yaw & Pitch **Roll**

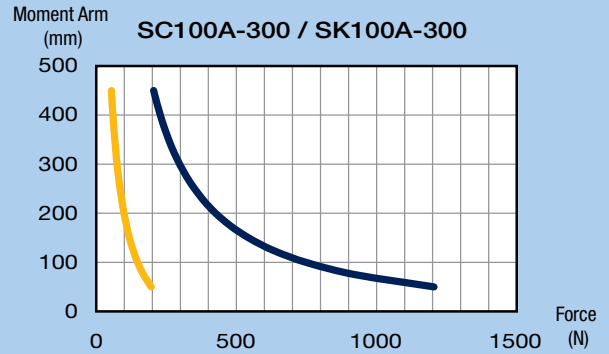
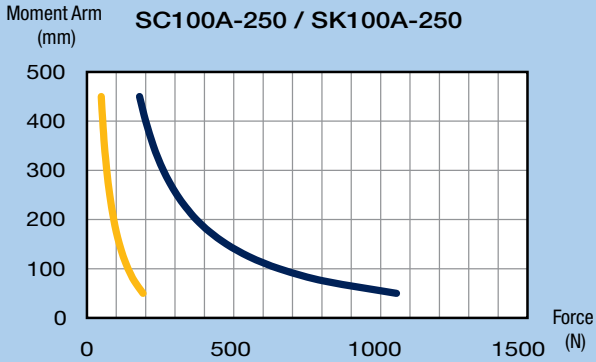
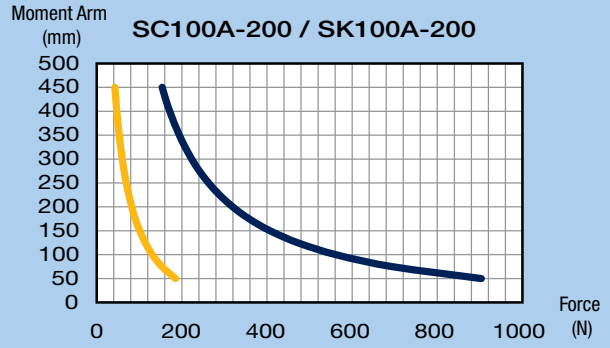
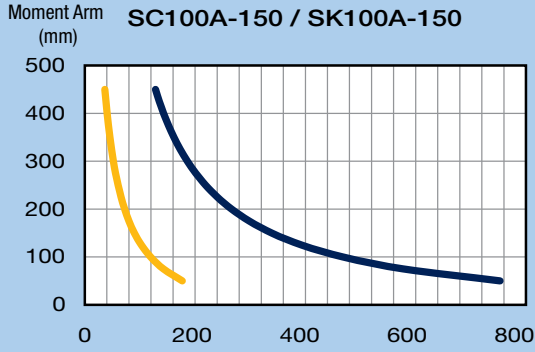

Yaw, Pitch, Roll

Yaw & Pitch Roll

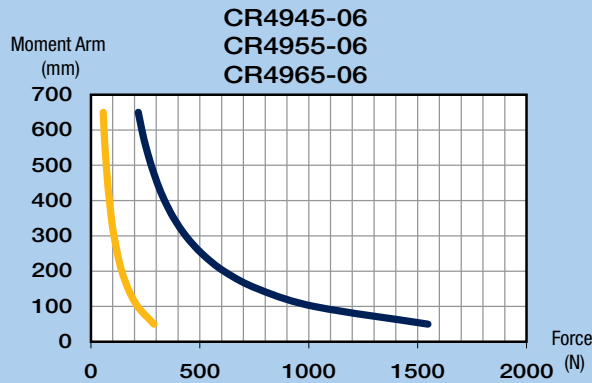
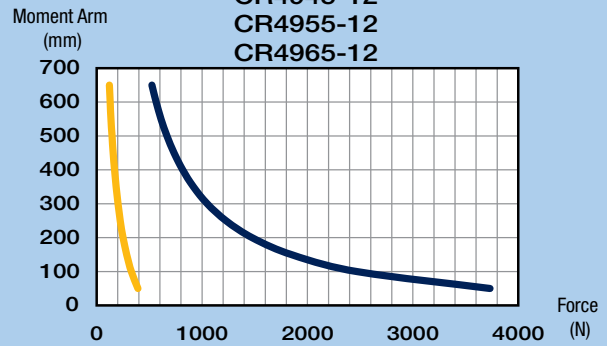
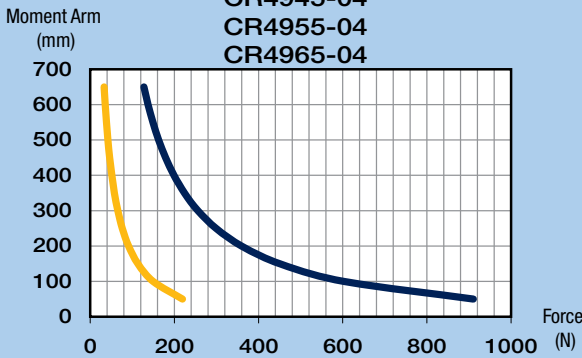
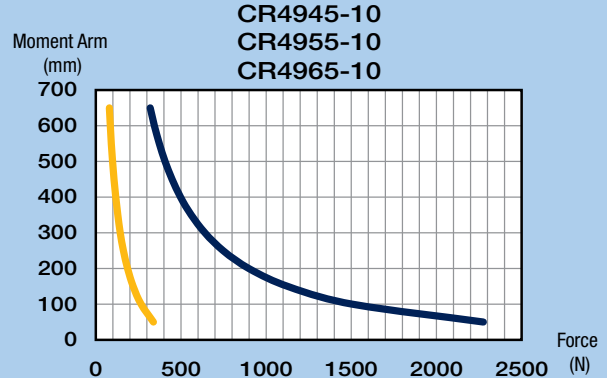
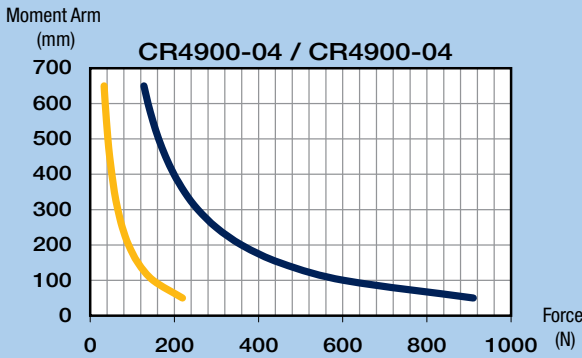
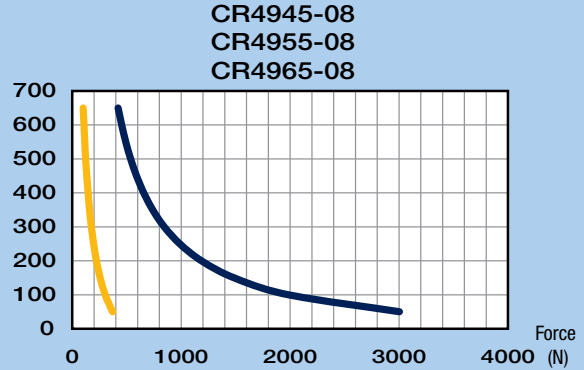
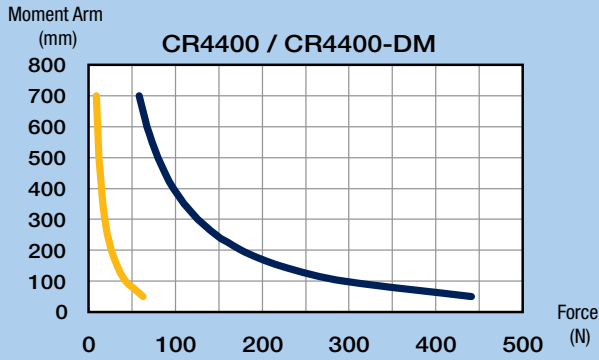

Rotary Positioners

Tangent Arm and Worm Gear Drive

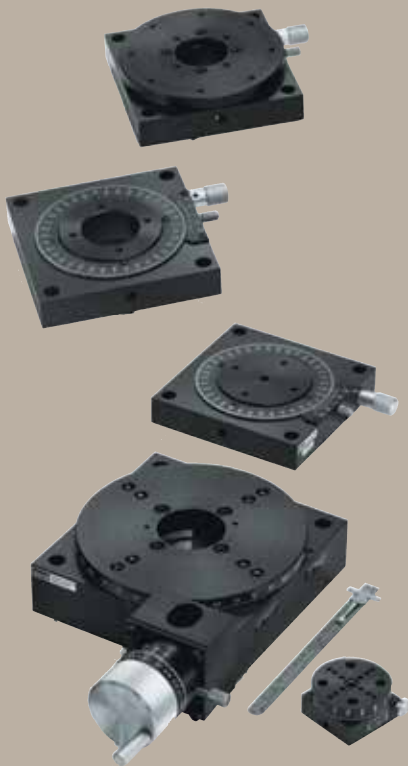

Parker rotary stages are designed to produce precision rotary motion. The basic components in these stages are a base, main bearing, drive mechanism and top (load platform). The base houses the main bearing and drive mechanism and is design to be mounted to a stationary surface. The main bearings provide low friction contact between the base and top. The drive mechanisms used are either tangent arms or worm gears. The table top provides a mounting surface for mounting payloads.

Contents

116	Overview
117	1.88 – 2.62" (47,8 – 66,5 mm) Diameter Tables
118	2.38" (60,5 mm) Diameter Tables
119	2.75 – 4.75" Diameter Tables
120-121	5.0 – 12.0" Diameter Tables
122	Performance Curves

Rotary Positioning Stages



- Precision quality
- Budget friendly
- Largest selection
- Rotary-linear configurations
- No maintenance
- Vacuum preparation and custom options

Rotary Positioner Principles

Parker rotary stages and tables produce controlled rotation and angular positioning.

Tangent Arm Drive

With some stages (models 2520, 2525, 4575), the drive mechanism is a tangent arm drive. Angular rotation, with this system, is controlled by three control knobs. The release knob disengages the shaft from the drive, freeing the table to be rotated by hand to a desired location. The release knob is then tightened to re-engage the drive mechanism and transfer control to the adjustment knob which, when rotated, produces precise angular positioning of the shaft and table top. The locking knob can then be used to positively lock the table at the desired setting.

Precision Worm Gear Drive

A precision worm gear drive is employed as the drive mechanism for the other Parker stages. A worm wheel (gear), which is attached to the table shaft, meshes with the worm drive, whose shaft extends out of the housing. Controlled rotation of the worm shaft creates precise angular rotation of the worm wheel and table shaft. The worm gear and shaft are matched sets and are preloaded to remove backlash. This type of drive provides high resolution (180:1) and continuous angular positioning over a full 360° range.

Standard Features

Parker has engineered all of its rotary positioners with emphasis on construction and detail. The resulting stages exhibit outstanding quality and proven, reliable performance. All models are manufactured on the very best automated equipment, skillfully assembled, and thoroughly inspected and tested. This enables units manufactured in production quantities to satisfy critical performance specifications. All Parker Daedal rotary positioning devices feature:

- Aluminum/steel construction
- Protective black anodize finish
- Low-friction rotary adjustment
- Precise/accurate movement
- Trouble-free operation

How to Order

Use the Selection Chart below to determine the appropriate model series. Refer to individual series pages for complete performance and mechanical specifications. To order, use the model number specific to the selected table.

Model Series	Table Diameter	Drive Mechanism	Normal Load	Mounting		Page
				Imperial	Metric	
2500 M2500	1.88 – 2.62 in 47,7 – 66,5 mm	Tangent Arm	10 lb 4,5 kg	•	•	117
4575* M4575*	2.38 in 60,5 mm	Tangent Arm	5 lbs 2,25 kg	•	•	118
10000-20000 M10000-M20000	2.75 – 4.75 in 69,8 – 120,6 mm	Worm Gear	50 lbs 22,0 kg	•	•	119
30000 M30000	5.00 – 12.00 in 127,0 – 305,0 mm	Worm Gear	25 – 200 lbs 11,5 – 90,0 kg	•	•	120-121

* Models 4575/M4575 are combination rotary and linear stages which also provide 0.50 in (12,7 mm) of linear travel.



Series 2500 rotary positioners offer low-friction rotary positioning, quick manual table top rotation, precise angular adjustment at any selected position, and positive locking. These miniature units have a preloaded angular contact ball bearing system which provides smooth, continuous rotary movement.

Models 2525/M2525 and 2535/M2535 include a dial and vernier for direct position readout (readable to six arc-minutes). These stages can be mounted in a horizontal or vertical position, and can be combined with compatible linear stages for linear-rotary applications.



2500/M2500 Series

Specifications	Imperial Models	Metric Models
Load:		
Normal Moment	10 lbs See page 122	4,5 kg See page 122
Range:	360° (free rotation) 10° (fine positioning)	360° (free rotation) 10° (fine positioning)
Weight:	1.0 – 1.8 lbs	0,5 – 0,8 kg
Vernier Resolution:	12 arc-min	12 arc-min
Construction:	Aluminum top and base; steel tangent arm drive	Aluminum top and base; steel tangent arm drive
Mounting surface:	Precision machined	Precision machined
Finish:	Black anodize	Black anodize

Dimensions

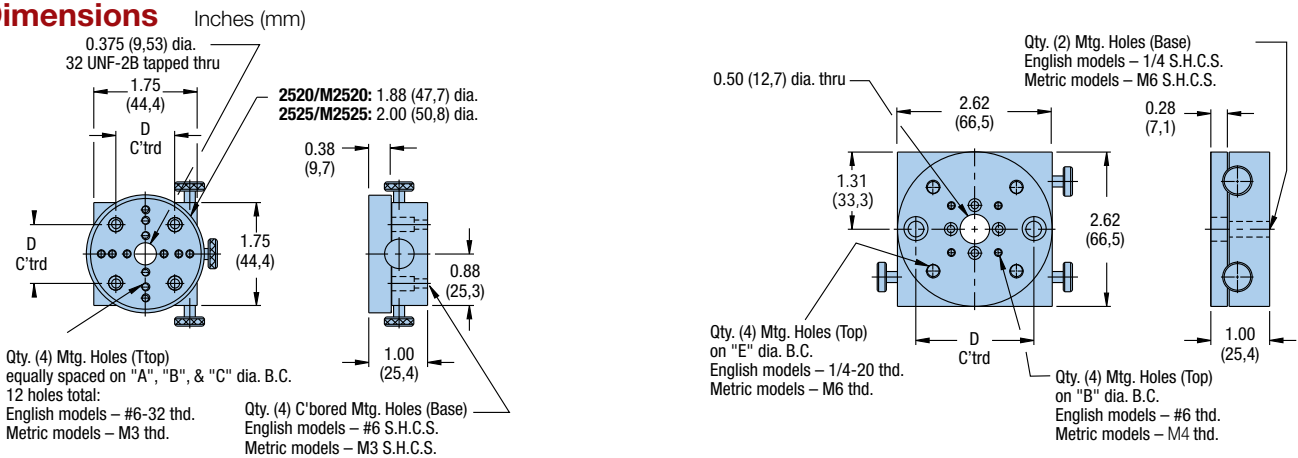

Model	Diameter in (mm)	Vernier Readout	Aperture Diameter in (mm)	Weight lbs (kg)	Dimensions – in (mm)				
					A	B	C	D	E
Imperial	2520	No	0.25	1.0	0.625	1.125	1.50	1.00	–
	2525	Yes	0.25	1.0	0.625	1.125	1.50	1.00	–
	2530	No	0.50	1.8	–	1.125	–	2.00	2.00
	2535	Yes	0.50	1.8	–	1.125	–	2.00	2.00
Metric	M2520	No	(6,3)	(0,5)	(15,0)	(25,0)	(35,0)	(25,0)	–
	M2525	Yes	(6,3)	(0,5)	(15,0)	(25,0)	(35,0)	(25,0)	–
	M2530	No	(12,7)	(0,8)	–	(25,0)	–	(50,0)	(50,0)
	M2535	Yes	(12,7)	(0,8)	–	(25,0)	–	(50,0)	(50,0)

Combination Linear/Rotary Positioner

The model 4575 combines both linear and rotary motion into one compact unit. It is designed for applications where space restrictions do not allow stacking a linear stage and a rotary stage. The mounting surface is 2.38" diameter with a 0.75" diameter thru hole, with (4) #10-32 threaded mounting holes on 2.00" centers. Linear travel is provided by a fine resolution micrometer. Rotary travel is provided with both a coarse and a fine adjustment. This feature allows quick rotation over a continuous 360° range, plus precise angular adjustment at any selected position.



4575/M4575 Series

Specifications	Imperial Models	Metric Models
Load:		
Normal Moment	15 lbs See page 122	2,25 kg See page 122
Range:		
Rotary	360° (free rotation) 10° (fine positioning)	360° (free rotation) 10° (fine positioning)
Linear	0.50 in	12,7 mm
Straight line accuracy:	0.0001 in	2,5 µm
Micrometer graduations:	0.001 in	0,01 mm
Weight:	1.0 lb	0,5 kg
Construction:	Aluminum top and base; steel tangent arm drive	Aluminum top and base; steel tangent arm drive
Mounting surface:	Precision machined	Precision machined
Finish:	Black anodize	Black anodize

Dimensions

Inches (mm)

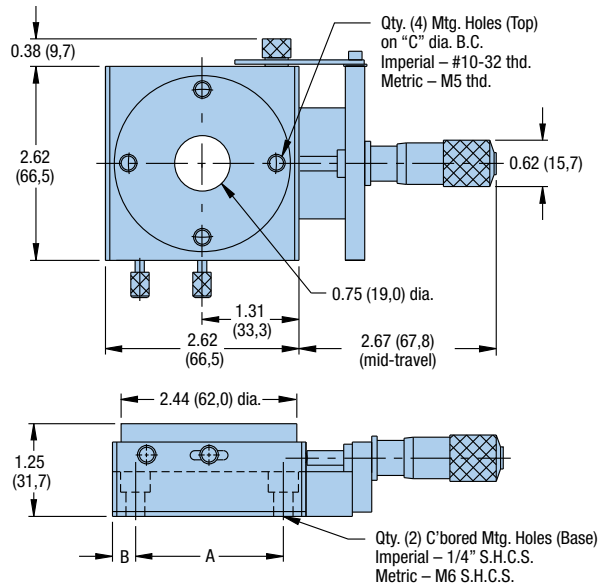

Model	Diameter in (mm)	Aperture Diameter in (mm)	Dimensions – in (mm)		
			A	B	C
Imperial 4575	2.62	0.75	2.00	0.31	2.00
Metric M4575	(66,5)	(19,0)	(50,0)	(8,3)	(50,0)



The 10000-20000 and M10000-M20000 Series rotary positioning stages provide smooth, continuous adjustment over a full 360° travel range. The drive mechanism features a worm gear drive. A position locking knob allows the stage to be positively locked in place. The 10000 and 20000 models offer a 2.75 inch (69,8 mm) diameter stage with a calibrated dial and vernier, readable to 6.00 arc minutes. The 10001 and 20001 models, which do not include the vernier readout, offer a larger 4.75 inch (120,6 mm) diameter mounting surface. These versatile low cost units can be combined with linear positioning stages having 4.00 inch (Imperial) or 100,0 mm (Metric) mounting hole centers for multi-axis polar set-ups.



10000-20000/M10000-M20000 Series

Specifications	Imperial Models				Metric Models			
	10000	10001	20000	20001	M10000	M10001	M20000	M20001
Table Diameter:	2.75 in	4.75 in	2.75 in	4.75 in	69,8 mm	120,7 mm	69,8 mm	120,7 mm
Vernier Resolution:	6 arc-min	–	6 arc-min	–	6 arc-min	–	6 arc-min	–
Aperture:	0.25	0.25	1.50	1.50	(6,3)	(6,3)	(38,1)	(38,1)
Weight:	2.0 lbs	2.4 lbs	2.0 lbs	2.4 lbs	0,9 kg	1,9 kg	0,9 kg	1,9 kg
Load:								
Normal	25 lbs				11,3 kg			
Moment	Not recommended for moment loads				Not recommended for moment loads			
Range:	360° (continuous)				360° (continuous)			
Drive Ratio:	120:1				120:1			
Construction:	Aluminum top and base; steel/bronze worm gear drive				Aluminum top and base; steel/bronze worm gear drive			
Mounting surface:	Precision machined				Precision machined			
Finish:	Black anodize				Black anodize			

Dimensions Inches (mm)

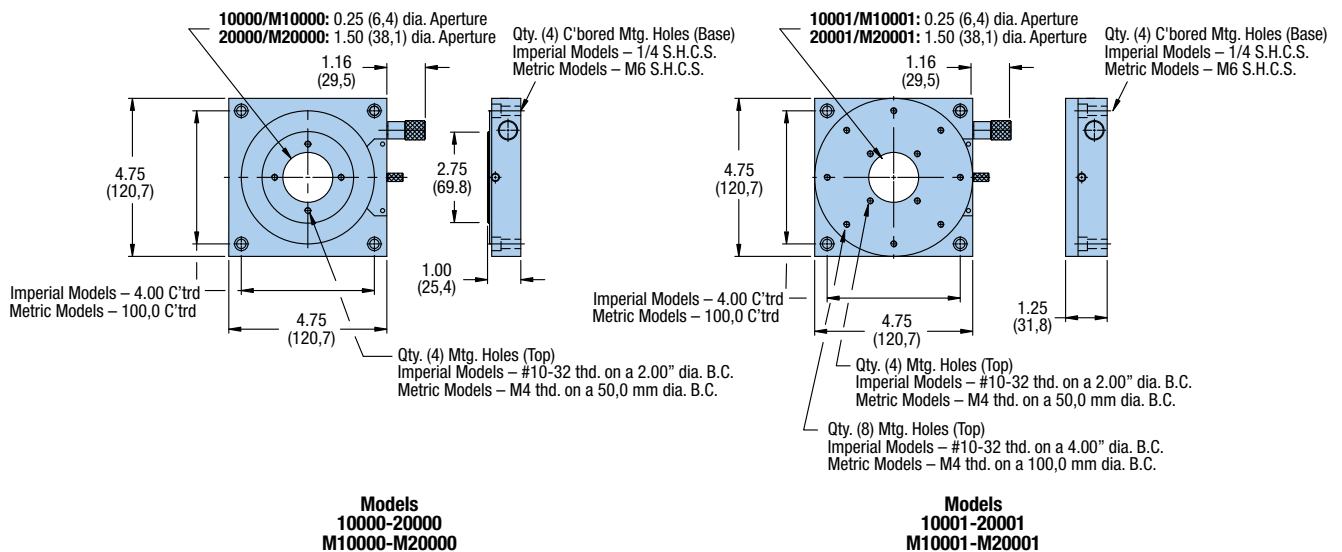

Parker rotary indexing tables provide accurate rotational positioning with a heavy load-carrying capability. Tables feature a crossed roller bearing system which is stiffly pre-loaded to produce precise rotation of the table top. The drive mechanism is a precision worm gear drive which provides precise rotational positioning.

An angular readout—graduated in degrees—is provided around the circumference of the table top, while a finer position readout dial, found on the control knob, reads directly in 0.01° increments, with the vernier providing even higher (0.002°) resolution. A thumbscrew lock is included to lock the table at the desired setting.

For customer convenience, threaded mounting holes with locking threaded inserts are provided as well as a clearance hole through the center of the table to allow easy access from below.

If desired, the table top can easily be removed to permit custom modification. These units can be mounted in any orientation and are compatible with Parker linear tables.

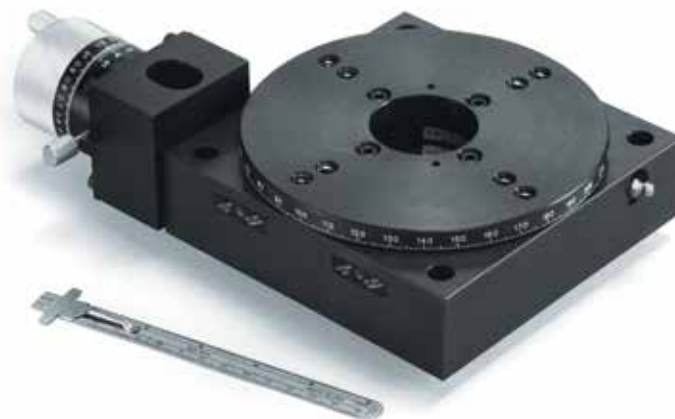

30000/M30000 Series

Specifications	Imperial Models	Metric Models
Load:		
Normal Moment	25 – 200 lbs See page 122	11,5 – 90 kg See page 122
Concentricity:		
Standard	0.005 in	127,0 µm
Precision	0.001 in	25,4 µm
Runout:		
Standard	0.003 in	75 µm
Precision	0.001 in	25 µm
Range:	360° (continuous)	360° (continuous)
Weight:	6.0 – 31.0 lbs	2,7– 14,1 kg
Vernier Resolution:	0.12 arc-min	0.12 arc-min
Construction:	Aluminum top and base; steel/bronze worm gear drive	Aluminum top and base; steel/bronze worm gear drive
Mounting surface:	Precision machined	Precision machined
Finish:	Black anodize	Black anodize

	Model		Table Diameter in (mm)	Normal Load lbs (kg)	Output Torque in-lb (Nm)	Weight lbs (kg)
	Standard	Precision				
Imperial	30005-S	30005-P	5.00	25	25	6.0
	30006-S	30006-P	6.00	150	40	8.0
	30008-S	30008-P	8.00	150	40	15.0
	30010-S	30010-P	10.00	200	190	27.0
	30012-S	30012-P	12.00	200	190	31.0
Metric	M30005-S	M30005-P	(127,0)	(11,5)	(2,8)	(2,7)
	M30006-S	M30006-P	(152,4)	(68,0)	(4,5)	(3,6)
	M30008-S	M30008-P	(203,2)	(34,0)	(4,5)	(6,8)
	M30010-S	M30010-P	(254,0)	(90,0)	(21,5)	(12,2)
	M30012-S	M30012-P	(304,8)	(90,0)	(21,5)	(14,1)



Dimensions Inches (mm)

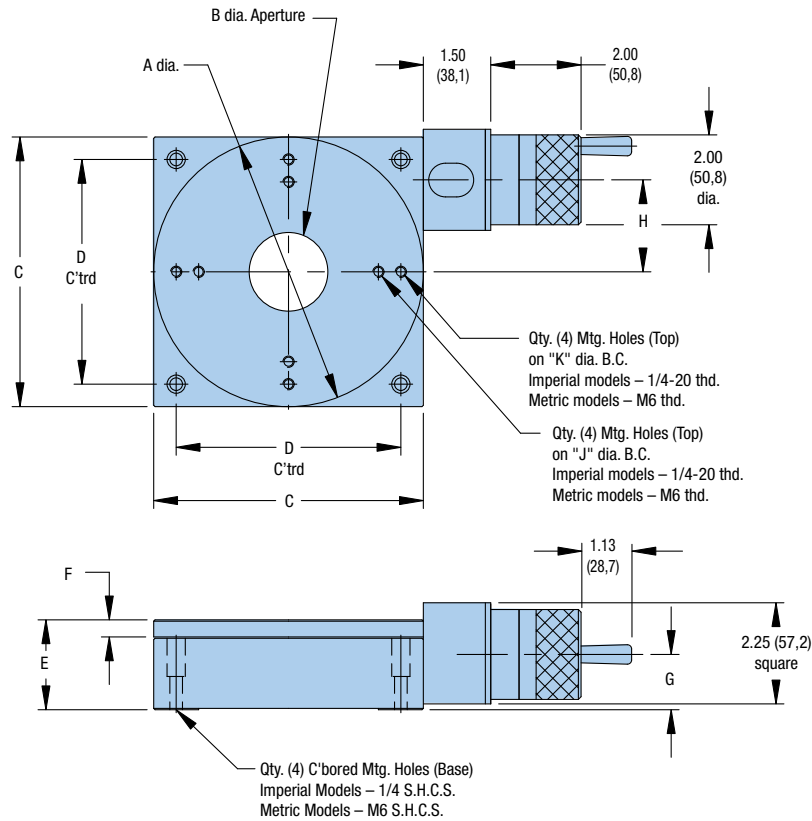

		Dimensions – in (mm)									
Model	A	B	C	D	E	F	G	H	J	K	
Imperial	30005-S/P	5.00	1.00	5.00	4.00	1.82	0.38	1.13	1.67	3.00	4.00
	30006-S/P	6.00	1.75	6.00	5.00	2.00	0.38	1.23	2.04	4.00	5.00
	30008-S/P	8.00	1.75	8.00	6.00	2.50	0.50	1.57	2.04	4.00	6.00
	30010-S/P	10.00	2.00	10.00	9.00	3.00	0.75	1.81	3.03	6.00	8.00
	30012-S/P	12.00	2.00	10.00	9.00	3.00	0.75	1.81	3.03	8.00	10.00
Metric	M30005-S/P	(127,0)	(25,4)	(127,0)	(100,0)	(46,2)	(9,7)	(28,7)	(42,4)	(75,0)	(100,0)
	M30006-S/P	(152,4)	(44,5)	(152,4)	(125,0)	(50,8)	(9,7)	(31,2)	(51,8)	(100,0)	(125,0)
	M30008-S/P	(203,2)	(44,5)	(203,2)	(175,0)	(63,5)	(12,7)	(39,9)	(51,8)	(100,0)	(175,0)
	M30010-S/P	(254,0)	(50,8)	(254,0)	(225,0)	(76,2)	(19,1)	(46,0)	(77,0)	(150,0)	(200,0)
	M30012-S/P	(304,8)	(50,8)	(254,0)	(225,0)	(76,2)	(19,1)	(46,0)	(77,0)	(200,0)	(250,0)

Moment Load

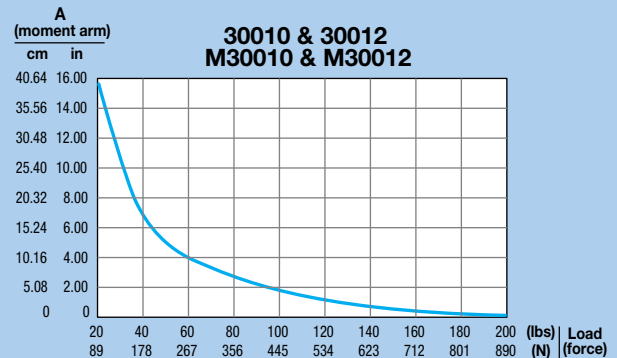
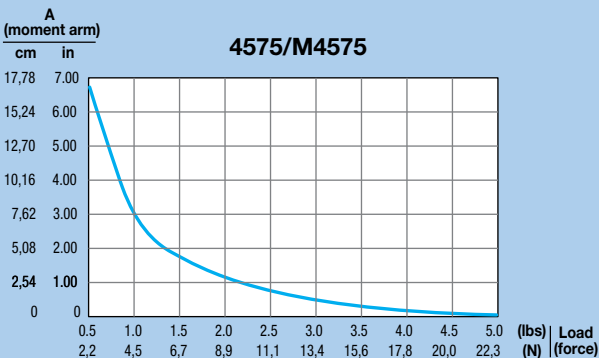
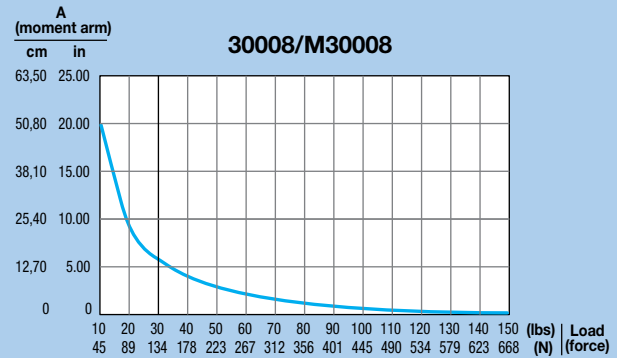
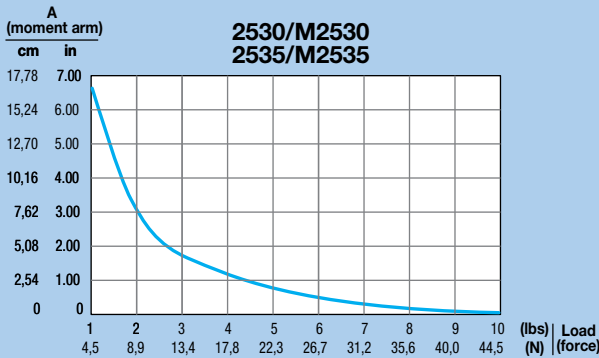
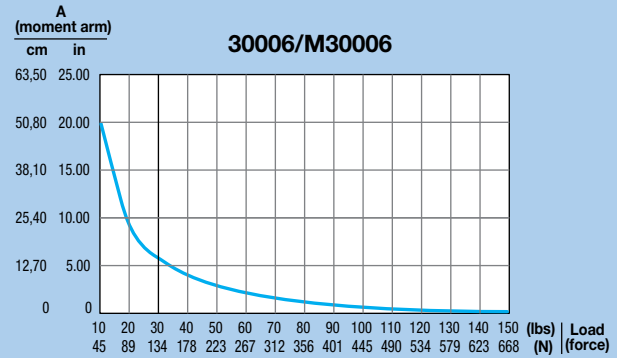
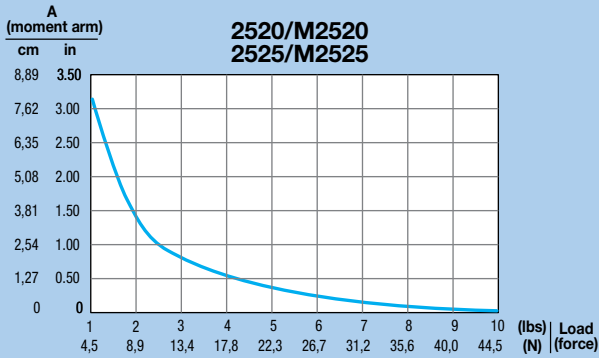
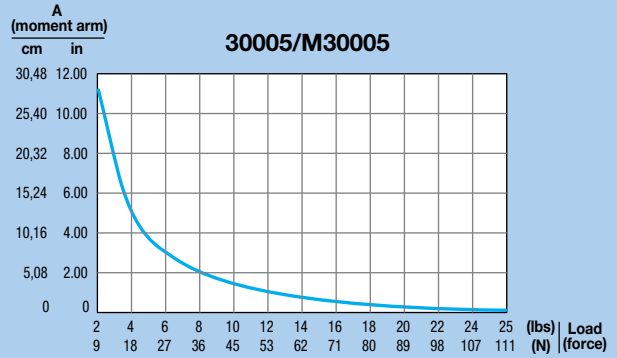
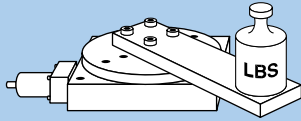

Accessories for Linear and Rotary Positioners



Parker offers a complete line of Z-axis brackets to combine ball bearing and cross roller stages into three axis positioning systems. We also offer drive mechanisms in an assortment of standard and digital micrometer heads, fine adjustment screws, and differential screws. Optical components including beam directors, optical mounts, mirror mounts and optical cells are also available.

Contents

124-127	Z-Axis Brackets
128-129	Micrometer Heads
130-132	Optical Mounts

Z-Axis Brackets

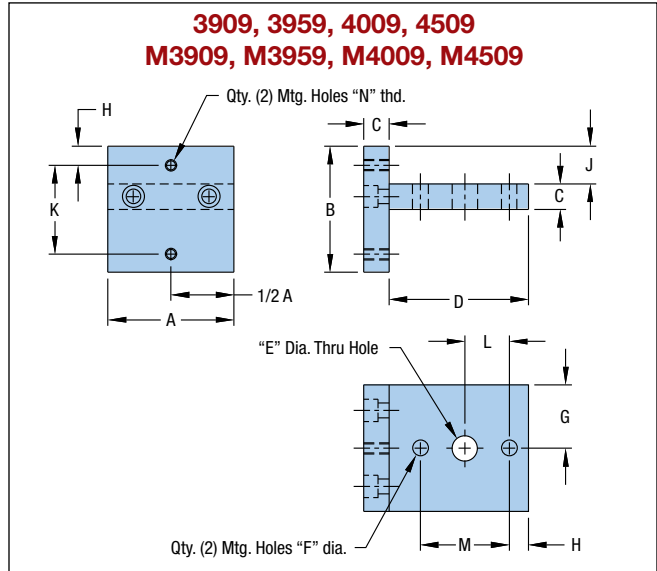

		Dimensions – in (mm)											Thd. N	
	Model	A	B	C	D	E	F	G	H	J	K	L	M	
Imperial	3909	1.25	1.25	0.25	1.38	0.25	0.156	0.62	0.19	0.38	0.88	0.44	0.88	#4-40
	3959	1.25	1.25	0.25	1.38	0.25	0.156	0.62	0.19	0.04	0.88	0.44	0.88	#4-40
	4009	1.75	1.69	0.25	1.88	—	0.156	0.88	0.31	0.63	1.12	—	1.12	#6-32
	4509	2.44	2.62	0.38	2.75	—	0.218	1.22	0.31	0.93	2.00	—	2.00	#10-32
Metric	M3909	(31,8)	(31,8)	(6,4)	(35,1)	(6,4)	(4,0)	(15,7)	(5,9)	(9,7)	(20,0)	(10,0)	(20,0)	M3
	M3959	(31,8)	(31,8)	(6,4)	(35,1)	(6,4)	(4,0)	(15,7)	(5,9)	(1,0)	(20,0)	(10,0)	(20,0)	M3
	M4009	(44,5)	(42,9)	(6,4)	(47,8)	—	(4,8)	(22,4)	(7,3)	(16,0)	(30,0)	—	(30,0)	M4
	M4509	(62,0)	(66,5)	(9,7)	(69,9)	—	(7,3)	(31,0)	(8,4)	(23,6)	(50,0)	—	(50,0)	M6

**3910, 3960
M3910, M3960**

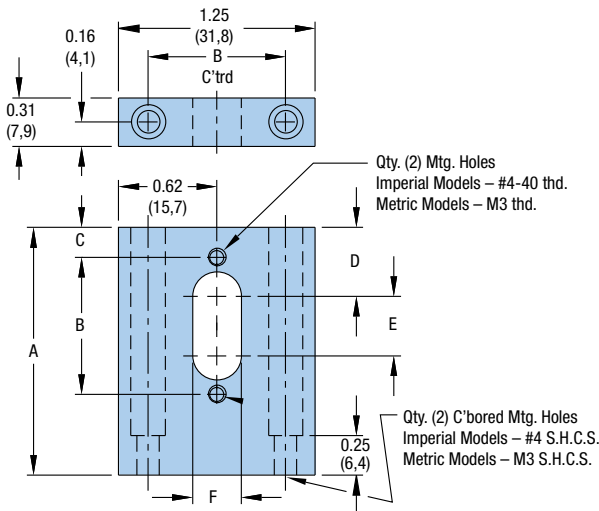

		Dimensions – in (mm)					
	Model	A	B	C	D	E	F
Imperial	3910	1.58	0.88	0.19	0.44	0.38	0.31
	3960	2.33	0.88	0.19	0.44	0.38	0.31
Metric	M3910	(40,1)	(20,0)	(5,9)	(12,3)	(7,1)	(6,4)
	M3960	(59,2)	(20,0)	(5,9)	(12,3)	(7,1)	(6,4)

**4010, 4020
M4010, M4020**

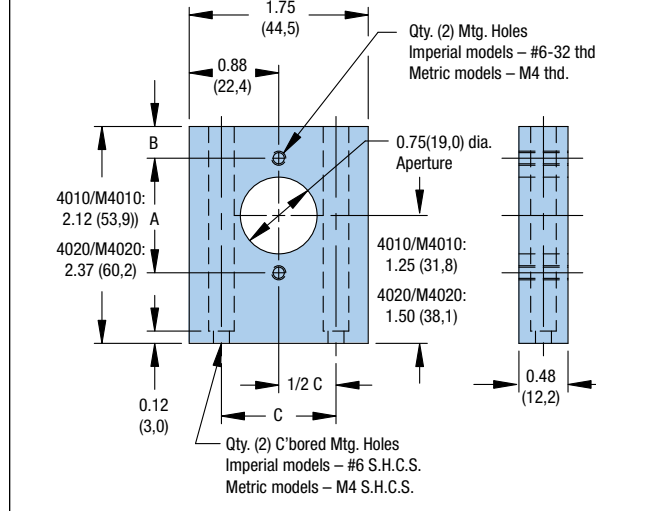

		Dimensions – in (mm)		
	Model	A	B	C
Imperial	4010	1.12	0.31	1.12
Metric	M4010	(30,0)	(7,1)	(30,0)



4059 M4059

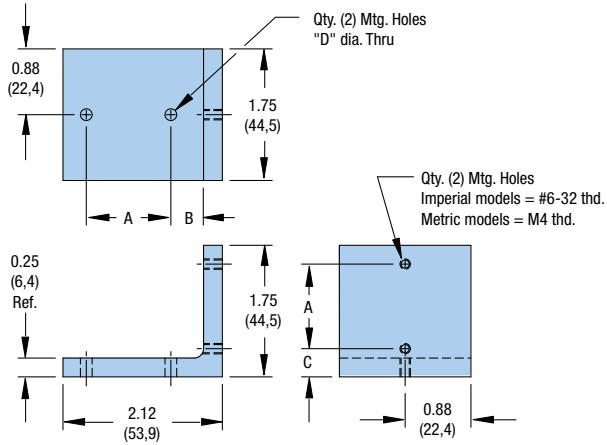

4059A M4059A

For 1.00 inch (25,0 mm) Travel Micrometer Option

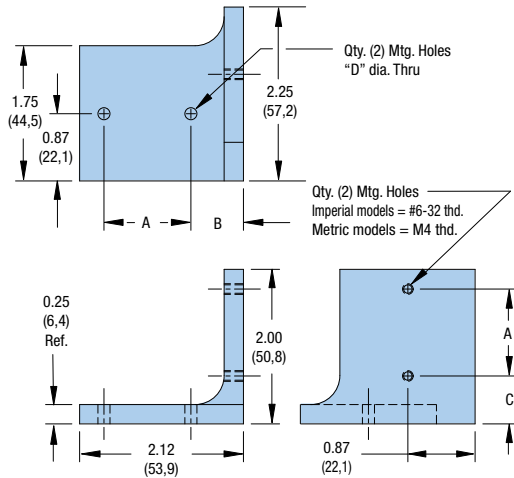

Dimensions - in (mm)

	Model	A	B	C	D
Imperial	4059	1.12	0.68	0.38	0.16
Metric	M4059	(30,0)	(16,8)	(8,8)	(4,8)

Dimensions - in (mm)

	Model	A	B	C	D
Imperial	4059A	1.12	0.68	0.62	0.16
Metric	M4059A	(30,0)	(16,8)	(15,2)	(4,8)

4060 M4060

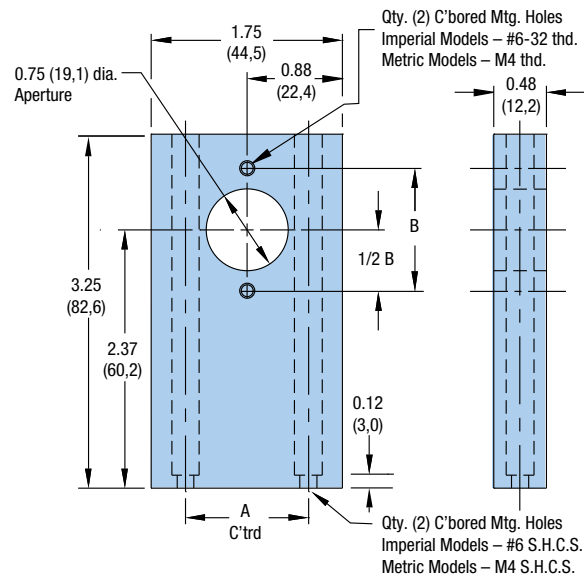

Dimensions - in (mm)

	Model	A	B
Imperial	4060	1.13	1.13
Metric	M4060	(30,0)	(30,0)

4510 M4510

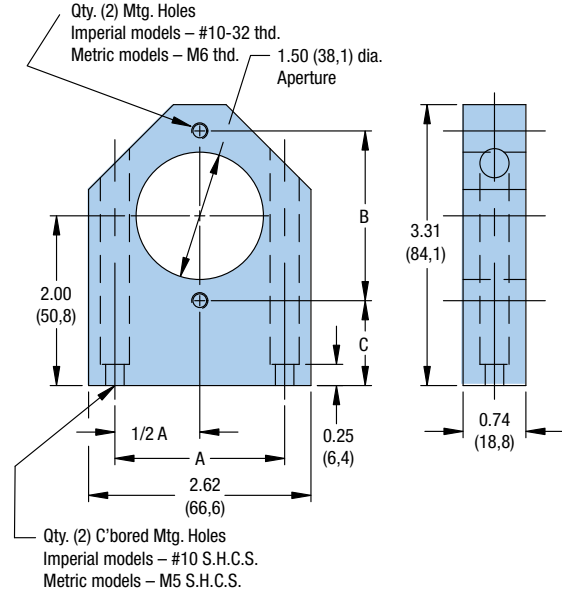

Dimensions - in (mm)

	Model	A	B	C
Imperial	4510	2.00	2.00	1.00
Metric	M4510	(50,0)	(50,0)	(25,8)

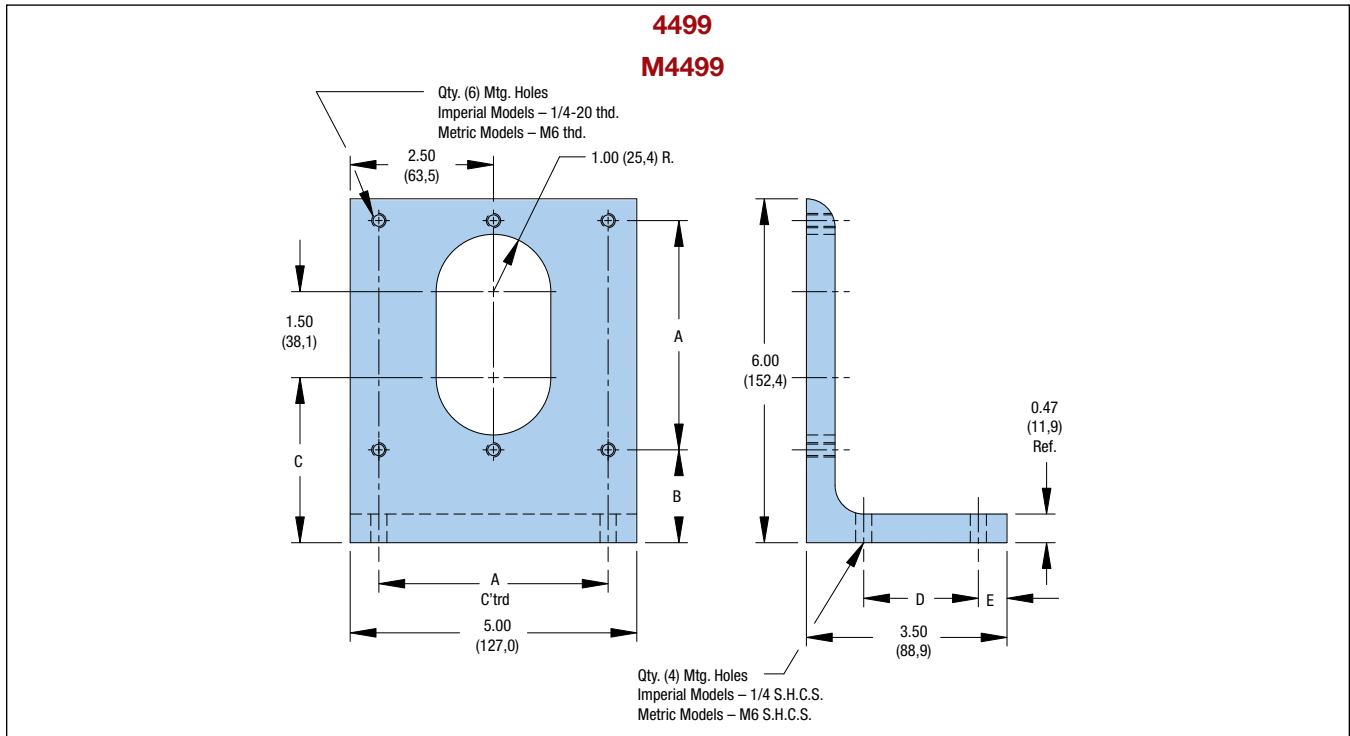

Dimensions – in (mm)					
	Model	A	B	C	E
Imperial	4499	4.00	1.62	2.88	0.50
Metric	M4499	(100,0)	(40,5)	(71,4)	(13,1)

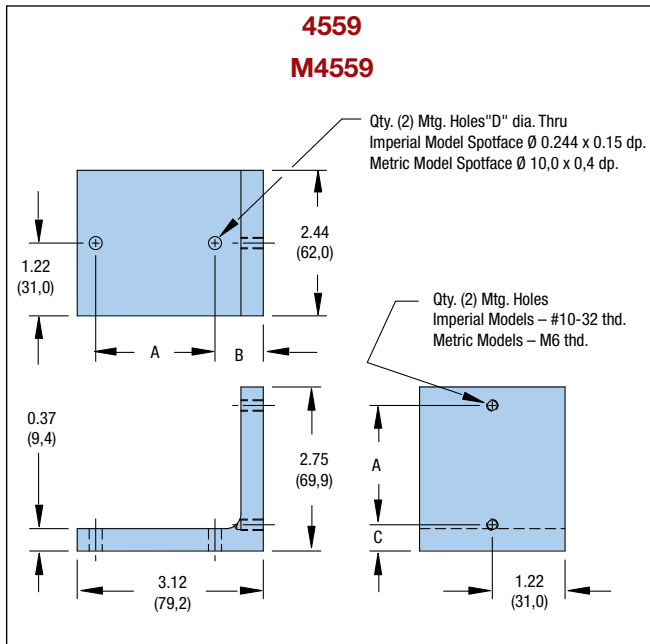

Dimensions – in (mm)				
	Model	A	B	D
Imperial	4559	2.00	0.81	0.22
Metric	M4559	(50,0)	(20,9)	(11,5)

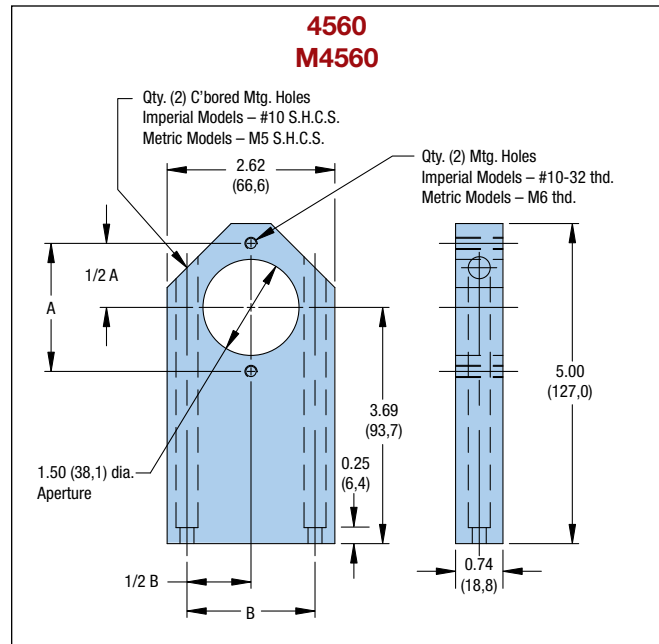

Dimensions – in (mm)			
	Model	A	B
Imperial	4560	2.00	2.00
Metric	M4560	(50,0)	(50,0)

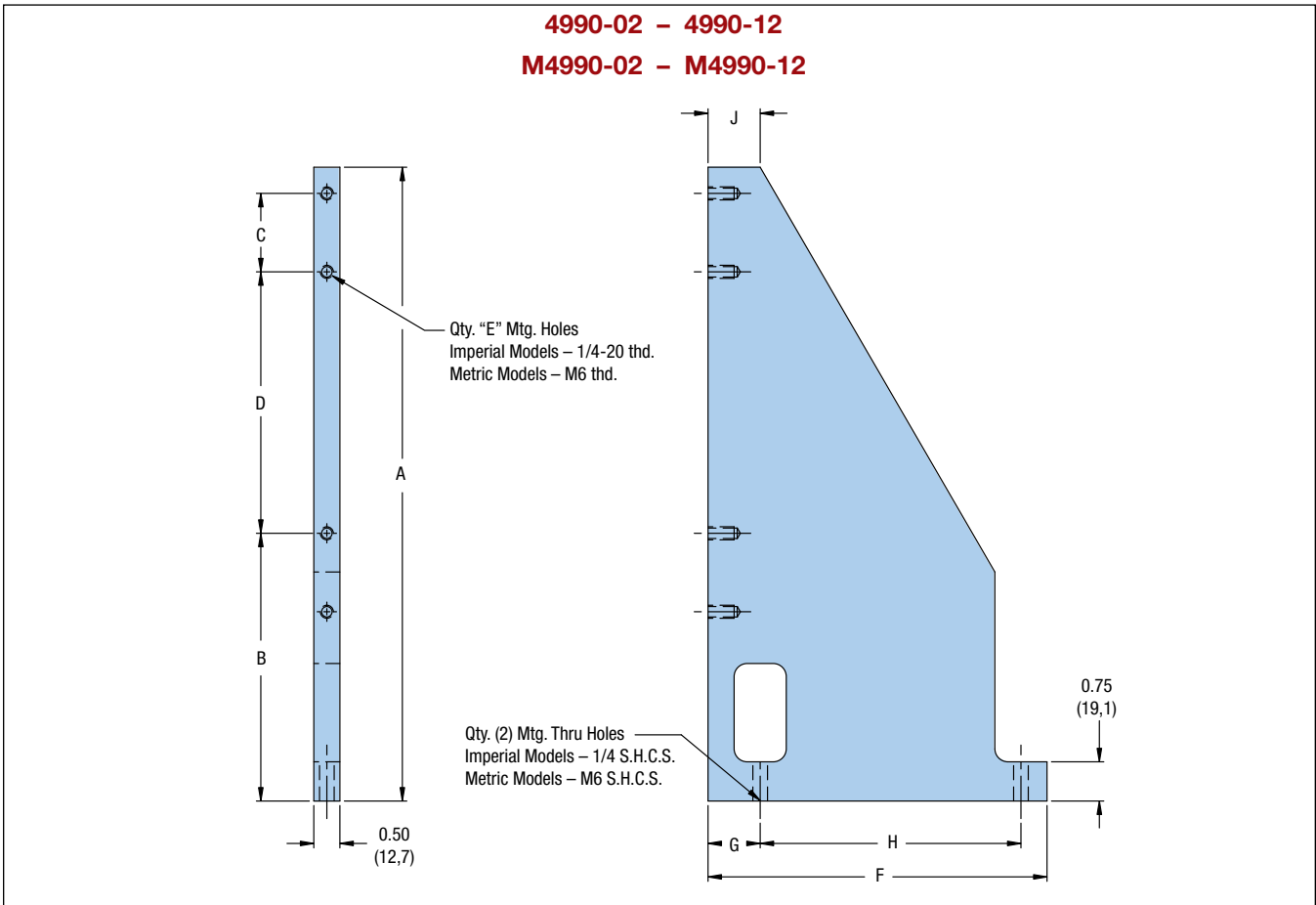

		Dimensions - in (mm)									
	Model	A	B	C	D	E	F	G	H	J	
Imperial	4990-02	6.00	1.50	-	4.00	2	5.50	1.00	4.00	1.00	
	4990-04	8.12	2.62	-	5.00	2	6.50	1.00	5.00	1.00	
	4990-06	12.12	5.12	1.5	5.00	4	6.50	1.00	5.00	1.00	
	4990-08	17.12	8.62	3.0	5.00	4	6.75	1.25	5.00	1.50	
	4990-10	20.50	10.00	4.0	6.00	4	6.75	1.25	5.00	1.50	
	4990-12	24.12	11.62	5.0	7.00	4	6.50	1.00	5.00	1.00	
Metric	M4990-02	(152,4)	(38,9)	-	(100,0)	2	(139,7)	(26,2)	(100,0)	(25,4)	
	M4990-04	(206,2)	(67,6)	-	(125,0)	2	(165,1)	(26,4)	(125,0)	(25,4)	
	M4990-06	(307,8)	(131,2)	(37,5)	(125,0)	4	(165,1)	(26,4)	(125,0)	(25,4)	
	M4990-08	(434,8)	(220,0)	(75,0)	(125,0)	4	(171,5)	(32,8)	(125,0)	(38,1)	
	M4990-10	(520,7)	(255,2)	(100,0)	(150,0)	4	(171,5)	(32,8)	(125,0)	(38,1)	
	M4990-12	(612,6)	(296,6)	(125,0)	(175,0)	4	(171,5)	(32,8)	(125,0)	(38,1)	

9510-9530 Series Micrometer Heads

Parker Daedal micrometer heads are recommended for any application requiring micrometer accuracy in settings and adjustment. These units feature a hardened and ground spindle, easy-to-read graduations, and an attractive non-glare satin chrome finish.

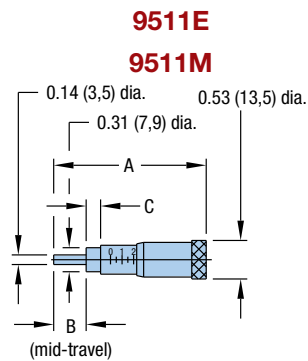

Figure A
Mini Thimble Micrometer Head

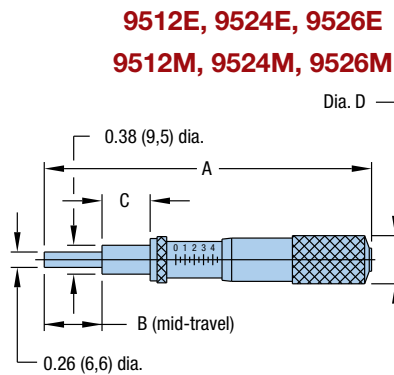

Figure B
Standard Thimble Micrometer Head

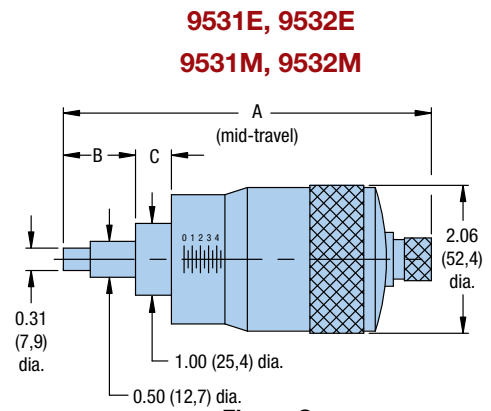

Figure C
Large Thimble Micrometer Head

		Model Number	Figure	Travel in (mm)	Graduations in (mm)	Dimensions – in (mm)			
						A	B	C	D
Imperial		9511E	A	0.50	0.001	2.03	0.50	0.187	—
		9512E	B	0.50	0.001	2.63	0.50	0.375	0.54
		9524E	B	1.00	0.001	4,23	0.75	0.625	0.73
		9526E	B	2.00	0.001	6.16	1.25	0.625	0.73
		9531E	C	1.00	0.0001	5.18	0.94	0.56	—
		9532E	C	2.00	0.0001	7.18	1.44	0.56	—
Metric		9511M	A	(13)	(0,01)	(51,6)	(13,0)	(4,7)	—
		9512M	B	(13)	(0,01)	(66,8)	(13,0)	(9,5)	(13,7)
		9524M	B	(25)	(0,01)	(107,4)	(19,0)	(15,9)	(18,5)
		9526M	B	(50)	(0,01)	(156,5)	(32,0)	(15,9)	(18,5)
		9531M	C	(25)	(0,002)	(131,6)	(23,9)	(14,2)	—
		9532M	C	(50)	(0,002)	(182,4)	(36,6)	(14,2)	—



9550 Series Digital Micrometer Heads

Model 9551

The 9551 precision electronic digital micrometer head provides an LCD readout to 0.00005 inch resolution. The micrometer features:

- Incremental and/or absolute positioning modes
- Zero set at any position, inch and millimeter readout (0.001 mm resolution), display hold, and automatic shutdown after two hours to conserve the integral battery
- 1.00 inch micrometer travel
- Battery powered for 500 hours of use

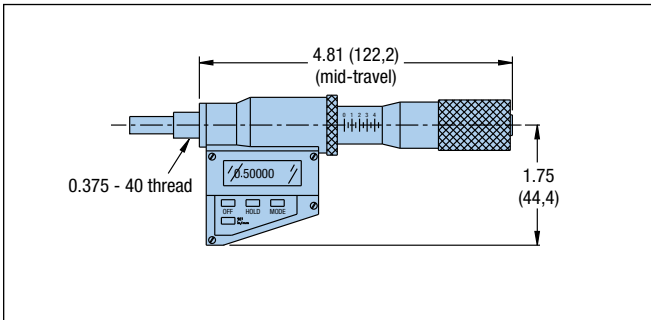

Model 9552

The 9552 precision electronic digital micrometer offers a 0 – 2 inch travel range with a 0.00005 inch resolution. Features include:

- 2 inch spindle
- Display face swivels for easy reading at various angles
- Non-rotating spindle
- Pre-set, zero, and inch/mm
- Carbide tipped measuring face
- Battery powered for 5,000 hours of use

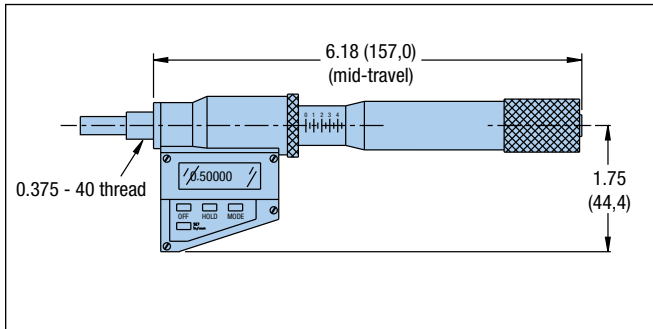

9560 Series Differential Screws

Model 9560: 0.75 in Range

The 9560 differential screw offers two linear adjustment ranges in one unit: a coarse adjustment range of 0.31 in (8 mm) with a 48-pitch thread and a fine adjustment range of 0.078 in (2 mm) with a pitch equal to 336 threads per inch. The 9560 is interchangeable with 9511 – 9532 series micrometer heads.

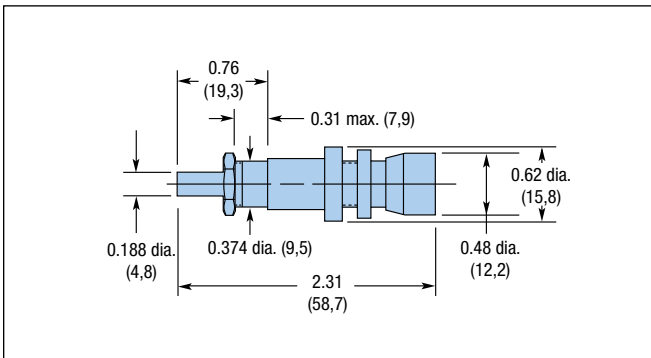

9570 Series Fine Adjustment Screws

Model 9570: 0.75 in Range

Model 9575: 0.50 in Range

These steel adjustment screws feature a 64-pitch thread, making them ideal for applications where finer resolution is required, but positional readout is not. These screws are easily interchanged with the 9511 – 9532 series micrometer heads.

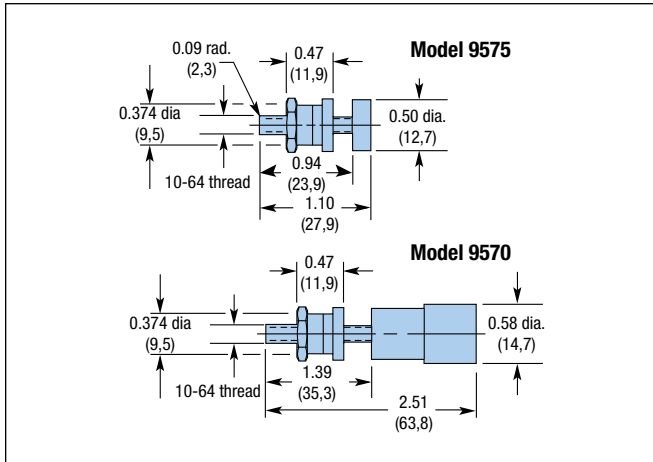

Optical Cell Mounts

Model 2350: 6.0" Diameter

Model 2355: 7.0" Diameter

Model 2360: 8.0" Diameter

Model 2365: 9.0" Diameter

Parker Daedal optical mounts are highly stable, adjustable mounts for optics up to 9" in diameter and 1.25" thick. These mounts feature precise kinematic ball pivot adjustment on two axes, with orthogonal three-point suspension.

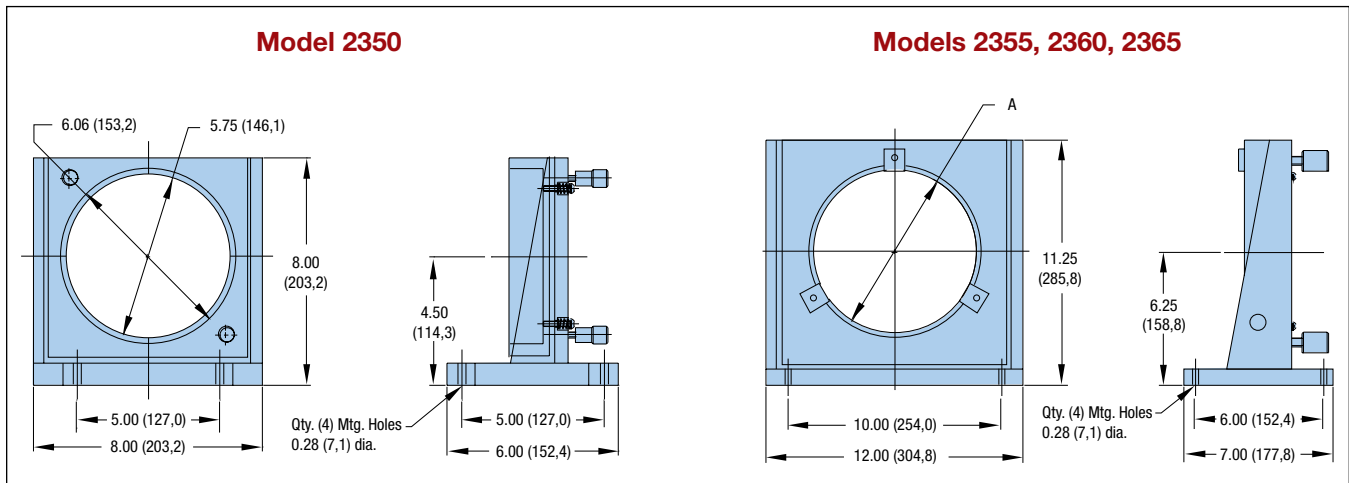

Specifications	2350	2355	2360	2365
Optic Size Opening – in (mm)				
Dimension "A" Dia. max.:	6.03 (153,1)	7.06 (179,3)	8.06 (204,7)	9.06 (230,1)
Thickness:	1.00 (25,4)	1.25 (31,75)	1.25 (31,7)	1.25 (31,7)
Optic Retention:	Threaded retainer	3 mounting clips	3 mounting clips	3 mounting clips
Range:	5°	5°	5°	5°
Resolution:	0.5 arc-sec	0.5 arc-sec	0.5 arc-sec	0.5 arc-sec
Adjustment:	2 – 64-pitch screws	3 – 32-pitch screws	3 – 32-pitch screws	3 – 32-pitch screws
Weight:	7.5 lb (16,5 kg)	20 lb (44 kg)	20 lb (44 kg)	20 lb (44 kg)
Construction:	Aluminum/stainless steel			
Finish:	Black anodize			



Optical Cell Mounts

Model 2370/2371: 10.0” Diameter

Model 2375/2376: 11.0” Diameter

Model 2380/2381: 12.0” Diameter

Parker Daedal optical mounts are highly stable, adjustable mounts for optics up to 12” in diameter and 2.0” thick. These mounts feature precise kinematic ball pivot adjustment on two axes, with orthogonal three-point suspension. Solid back models are designed to support reflective optics.

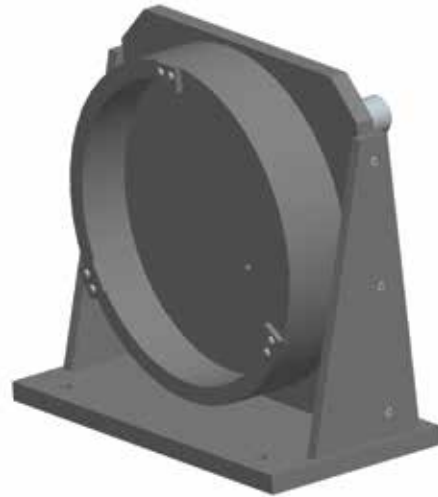

Crossed Roller Slides

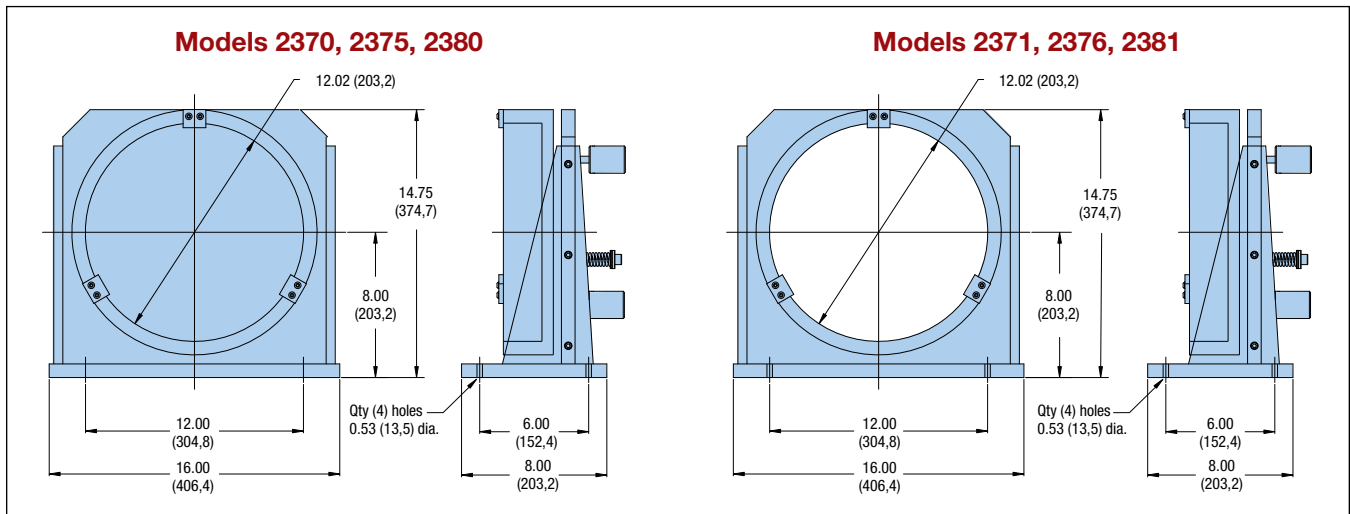

Specifications	Solid Back Models			Aperture Models		
	2370	2375	2380	2371	2376	2381
Optic Size Opening – in (mm)						
Dimension “A” Dia. max.:	10.02 (254,5)	11.02 (379,9)	12.02 (305,3)	10.06 (255,5)	11.06 (280,9)	12.06 (306,3)
Thickness:	2.00 (50,8)	2.00 (50,8)	2.00 (50,8)	2.00 (50,8)	2.00 (50,8)	2.00 (50,8)
Optic Retention:	3 mounting clips			3 mounting clips		
Range:	7°			7°		
Resolution:	0.5 arc-sec			0.5 arc-sec		
Adjustment:	3 – 32-pitch screws			3 – 32-pitch screws		
Weight:	45 lb (99 kg)			41 lb (90 kg)		
Construction:	Aluminum/stainless steel			Aluminum/stainless steel		
Finish:	Black anodize			Black anodize		

Mirror Mounts

Model 5000/5100: 3.0" Square Mounting Surface

Model 5300/5700: 4.5" Square Mounting Surface

Model 5800/5900: 6.0" Square Mounting Surface

Parker Daedal mirror mounts are patterned with 1/4-20 holes on 0.5" or 1.0" centers to mount mirrors and other hardware. All models except the 5800 have two fine resolution 64-pitch adjustment screws to provide precise tilting of the mounting surface in two axes. The 5800 is equipped with three adjustment screws to provide precise tilting in two axes.

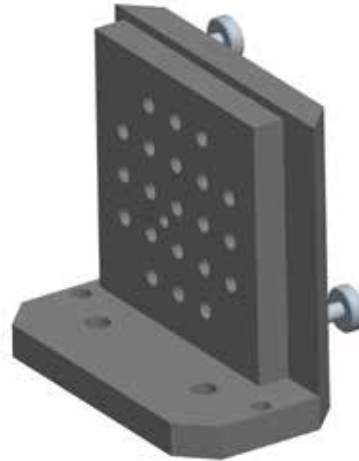

Specifications	Angled Base Models			Flat Base Models		
	5000	5300	5800	5100	5700	5900
Mounting Surface						
Size (Square) – in (mm)	3.0 (76,2)	4.5 (114,3)	6.0 (152,4)	3.0 (76,2)	4.5 (114,3)	6.0 (152,4)
Holes – (Qty. x Center)	21 x 0.50"	49 x 0.50"	25 x 1.0"	21 x 0.50"	49 x 0.50"	25 x 1.0"
Range:	12°	8°	4°	12°	8°	4°
Resolution:	1.0 arc-sec	0.75 arc-sec	0.5 arc-sec	1.0 arc-sec	0.75 arc-sec	0.5 arc-sec
Weight – lb (kg)	1 (2,2)	2 (4,4)	4.1 (9)	0.7 (1,5)	1.6 (3,5)	3 (6,6)
Adjustment:	2 – 64-pitch screws (3 screws on 5800)			2 – 64-pitch screws		
Construction:	Aluminum/stainless steel			Aluminum/stainless steel		
Finish:	Black anodize			Black anodize		

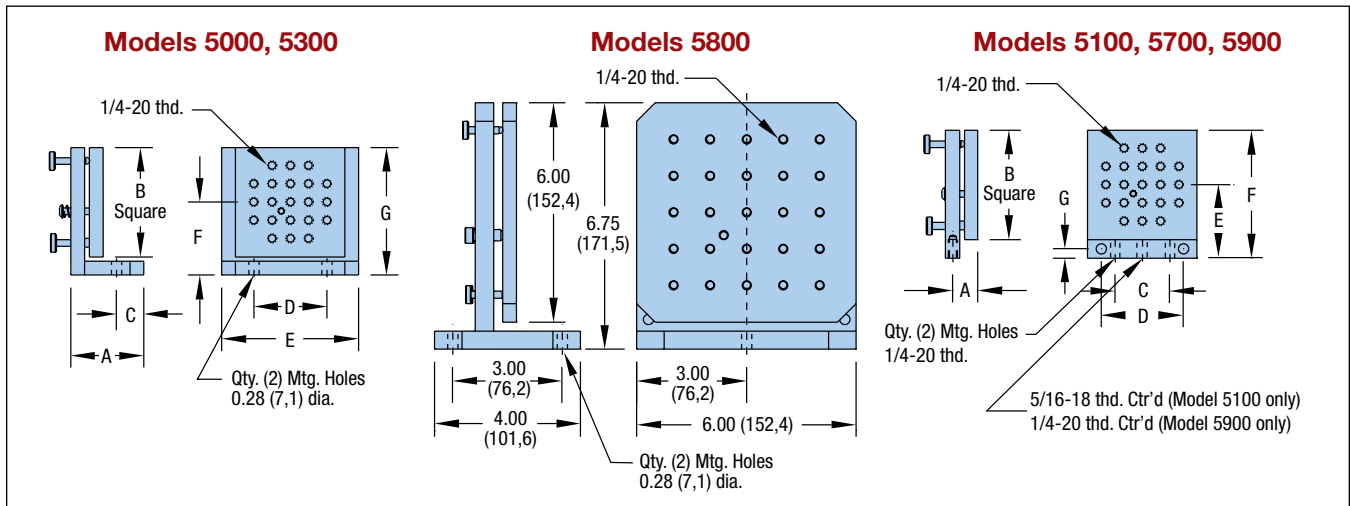

Model	Dimensions – in (mm)						
	A	B	D	D	E	F	G
5000	2.00 (50,8)	3.00 (76,2)	0.75 (19,1)	2.00 (50,8)	3.75 (95,3)	2.00 (50,8)	3.50 (88,9)
5300	3.00 (76,2)	4.50 (114,3)	1.25 (31,8)	4.00 (101,6)	4.50 (114,3)	2.88 (73,2)	5.12 (130,1)
5100	0.69 (17,5)	3.00 (76,2)	1.50 (38,1)	2.25 (57,2)	2.00 (50,8)	3.50 (88,9)	0.25 (6,4)
5700	0.69 (17,5)	4.50 (114,3)	3.00 (76,2)	3.75 (95,3)	2.88 (73,2)	5.12 (130,1)	0.25 (6,4)
5900	0.88 (2,4)	6.00 (152,4)	4.00 (101,6)	5.38 (136,7)	3.25 (82,6)	6.25 (158,8)	0.31 (7,9)

Travel

The travel listed is the total travel of the positioner from hard stop to hard stop.

Bearing Load Capacity

Normal Load

This is the maximum downward (compression) load or force which can be applied to the positioner perpendicular to the mounting surface. The center of force or the C.G. of the load must be located in the center of the mounting surface. For loads which are offset from this position, refer to moment loads.

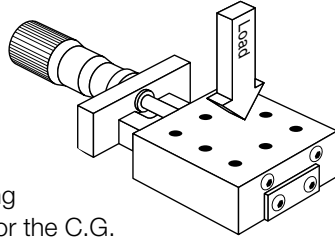

Inverted Load

Same as a normal load except in an upward (tension) direction.

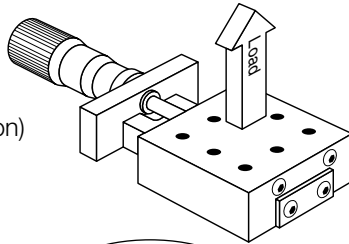

Moment Load

This refers to forces which are offset (cantilevered) from the bearing centers and therefore producing uneven loading on the bearings. This uneven loading means that some bearings are supporting more of the load than others. For this reason it is very important to determine if the moment loading for a given positioner is within acceptable limits. These moment forces are categorized by the direction they act in Pitch, Roll or Yaw; see diagram at left. When loading results in moments acting in only one of the moment directions (pitch, roll or yaw) it is called a single direction moment. Examples of this type of loading are shown below. How to calculate the maximum allowable moment load is discussed on the following page.

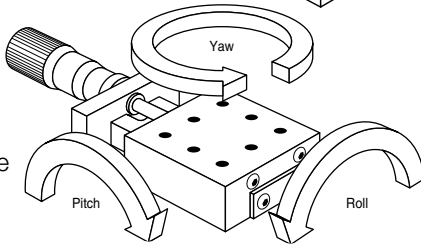

Thrust Capacity

Thrust capacity is the maximum force or load which can be applied in the direction of travel without damage to positioning stage components.

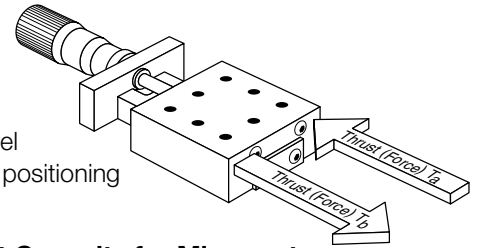

T_a and T_b Thrust Capacity for Micrometer, Fine Screw and Differential Screw Drives

With these types of drives the mounting surface or stage carriage is pressed against the drive mechanism by means of a spring. Because of this the maximum thrust which the stage assembly can maintain is different when pressing toward the spring or away from it. When pressing toward the spring, the force is taken up by the drive mechanism (i.e. micrometer). While pulling away, the force is being held in place by the spring. Stages with this type of mechanism have two thrust capacity specifications (T_a and T_b). T_a refers to the load capacity against the micrometer and T_b is the spring load capacity. Refer to specific product drawings for load direction.

Screw Drive Thrust Capacity

Stages which use screw drive assemblies will only have one thrust capacity rating. This rating is for either direction of travel.

Straight Line and Flatness Accuracy

This is the amount of error a linear positioner deviates from an ideal straight line. The straight line accuracy is the error in the horizontal plane while flatness is the error in the vertical plane. Both the straight line and the flatness accuracy are measured at the moving carriage surface center.

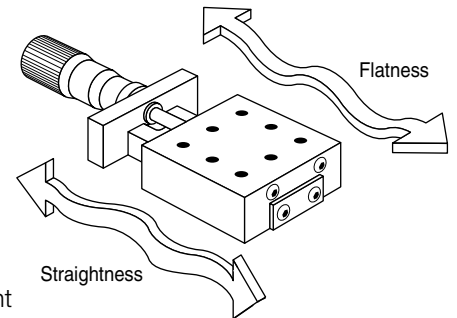

Pitch Moment

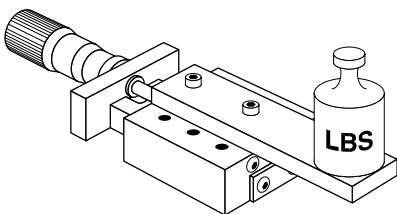

Roll Moment

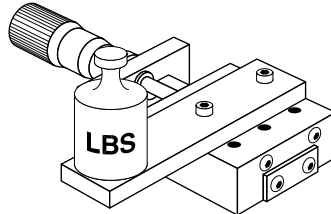

Compound Pitch/Roll Moment

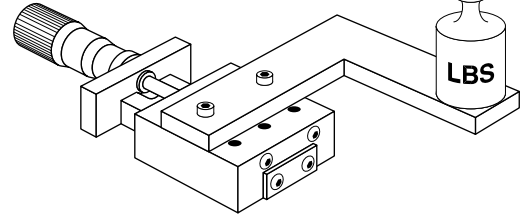

Calculating Maximum Allowable Moment Loads on Linear Slides and Stages

To determine if a load or force is within acceptable moment load ranges follow the steps below:

1. Calculate maximum load and or force which will be applied to the positioner. Include brackets and other axes which are mounted to the positioner.
2. Locate the center of gravity of the load.
3. Determine if there is a single or compound moment.
4. Measure the distance from the center of force or C.G. to the center of the linear stage carriage. This is the moment arm length and is designated A_S for single direction moments and A_C for compound moments.
5. Locate the moment load graph for the positioner you are interested in (located in back of individual product section, e see example below). The X axis of the graph is the Force, the Y axis is the allowable moment arm A_S for single direction moments.
6. Locate the moment curve(s) which your load is acting in (pitch, roll or yaw).
7. Locate your load force on the X axis of the graph.
8. Draw a vertical line from the Force location on the X axis parallel with the Y axis.
9. Find the moment arm distance on the Y axis. Draw a horizontal line from this point parallel with the X axis until the vertical and horizontal lines intersect.
10. If the intersection point is below the moment curve in question then the stage is within acceptable limits. If the intersection point is above the moment curve, a positioner with a larger normal load capacity should be selected and the above steps repeated.

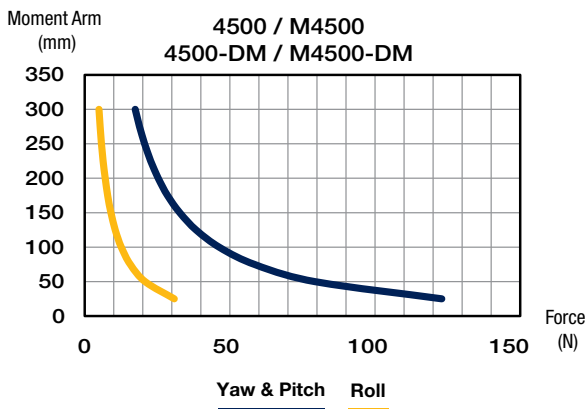

Example #1: Single Direction Moment Load

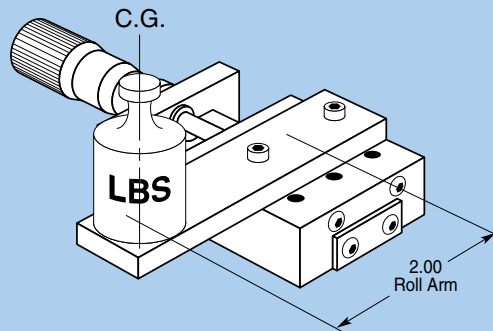

A 2 pound load is mounted to a single axis linear stage. The diagram shows the load's position in reference to the positioner carriage center. This shows that the load is offset 2 inches from the carriage center creating a roll moment.

The selected positioner is a 4502 ball stage. (The moment load curve for the 4502 is shown below.) First, find 2 pounds on the X axis and draw a vertical line. Next, draw a horizontal line starting at the 2 inches position on the A_S axis (single direction moment). Mark the intersection point.

In this example the intersection point is below the roll moment curve, indicating that the stage is acceptable for this application.

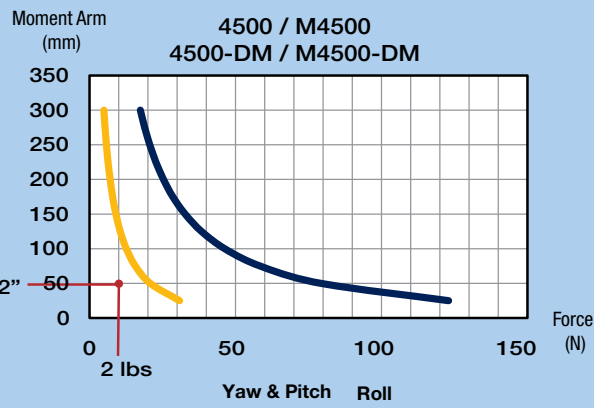

Main Bearing Load Capacity

Normal Load

This is the load or force which can be applied in a downward direction (Compression) on the rotary stage top. The center of force or C.G. of the load must be in the center of the mounting surface. For loads which are offset from the center, refer to moment loads.

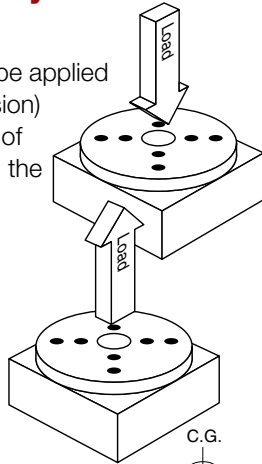

Inverted Load

Same as Normal load capacity except in an upward or tension direction.

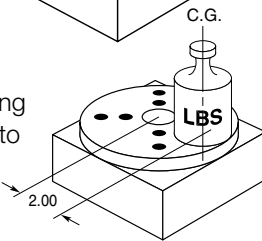

Moment Load

This specifies the maximum overhung load or force which can be applied to the rotary stage without damaging the mechanism. (See Calculating Moment Loads, below.)

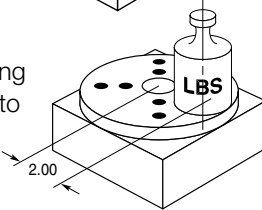

Maximum Output Torque

The maximum torque which the rotary stage can produce at the carriage without damage or excess wear to the mechanisms.

Concentricity

The maximum variance between a perfect circle and the path which the rotary stage follows. Concentricity is measured by placing a circular gauge disk on the table top and aligning it with the circular path of travel. An indicator is then placed on the gauge disk and the variance is measured as the concentricity error.

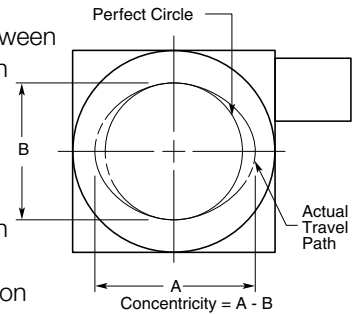

Axial Runout

Measured at the center of rotation, axial runout is the amount of vertical motion the rotary stage moves as it rotates.

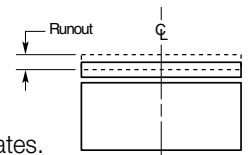

Calculating Maximum Allowable Moment Loads on Rotary Positioners

To determine if a load or force is within acceptable moment load ranges follow the steps below:

1. Calculate maximum load or force which will be applied to the Rotary stage. Include brackets, and other axes which are mounted to the rotary stage.
2. Locate the center of force or C.G. of the load.
3. Measure the distance from the center of force or C.G. to the center of the rotary stage. This is the moment arm and is designated A.
4. Locate the moment load graph for the rotary stage you are interested in (located in back of individual product section). The X axis of the graph is the Force, the Y axis is the allowable moment arm A.
5. Locate your load force on the X axis of the graph.
6. Draw a vertical line from the Force location on the X axis parallel with the Y axis.
7. Find the Moment Arm distance on the Y axis. Draw a horizontal line from this point parallel with the X axis until the vertical and horizontal lines intersect.
8. If the intersection point is below the moment curve then the stage is within acceptable limits. If the intersection point is above the moment curve a positioner with a larger normal load capacity should be selected and the above steps repeated.

Example: Rotary Stage Moment Load

A load of 12 pounds is mounted to a 30008 rotary table. The illustration shows the position of the load in reference to the center of rotation on the rotary table. The load is offset 6 inches from the rotation center. (The 30008 moment load curve is shown below for this example.)

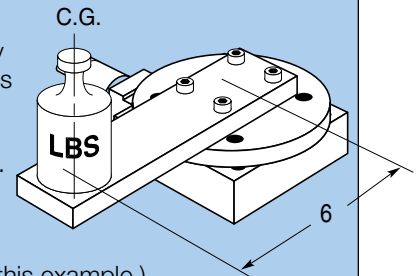

First find 12 pounds on the X axis and draw a vertical line parallel to the Y axis, next locate the moment arm distance on the Y axis. Draw a horizontal line from this point until it intersects with the vertical line. The intersection point is below the moment curve, thus the 30008 table is acceptable for this application.

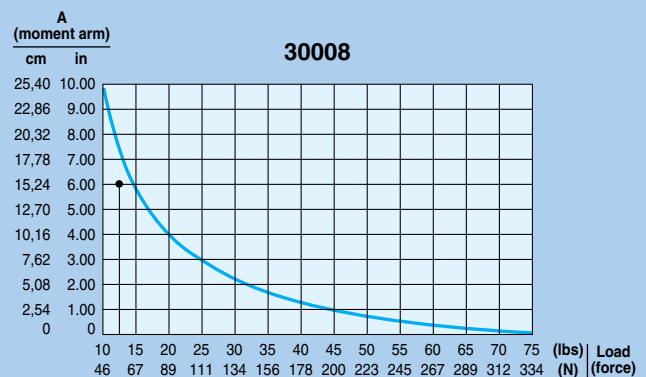

Model Number Index

Model Number	Page	Model Number	Page	Model Number	Page	Model Number	Page
105	Contact	3922	66	4008-DM	72	4073	68
106	Factory	3922M	66	4009	124	4074	68
2350	130	3923	66	4010	124	4074M	68
2355	130	3926	66	4022	68	4076	68
2360	130	3926M	66	4022D	68	4076D	68
2365	130	3927	66	4022M	68	4076M	68
2370	131	3932	66	4023	68	4077	68
2371	131	3932M	66	4024	68	4082	68
2370	131	3933	66	4024M	68	4082D	68
2371	131	3936	66	4026	68	4082M	68
2380	131	3936M	66	4026D	68	4083	68
2381	131	3937	66	4026M	68	4084	68
2450	Contact	3942	66	4027	68	4084M	68
	Factory	3942M	66	4032	68	4086	68
2520	117	3943	66	4032D	68	4086D	68
2525	117	3946	66	4032M	68	4086M	68
2530	117	3946M	66	4033	68	4087	68
2535	117	3947	66	4034	68	4092	68
2800		3952	66	4034M	68	4092D	68
2805		3952M	66	4036	68	4092M	68
2810	Contact	3956	66	4036D	68	4093	68
2850	Factory	3956M	66	4036M	68	4094	68
2900		3959	124	4037	68	4094M	68
3505-05	16	3960	124	4042	68	4096	68
3505-10	16	3972	66	4042D	68	4096D	68
3505-20	16	3972M	66	4042M	68	4096M	68
3505-30	16	3976	66	4043	68	4097	68
3507-05	17	3976M	66	4044	68	4101	22
3507-10	17	3982	66	4044M	68	4102	70
3507-20	17	3982M	66	4046	68	4102M	70
3507-30	17	3986	66	4046D	68	4103	70
3510-05	18	3986M	66	4046M	68	4104	70
3510-10	18	3992	66	4047	68	4104-DM	73
3510-20	18	3992M	66	4052	68	4104M	70
3511-07	19	3996	66	4052D	68	4201	22
3511-15	19	3996M	66	4052M	68	4202	70
3511-20	19	4001	21	4053	68	4202M	70
3511-30	19	4002	68	4054	68	4203	70
3511-40	19	4002D	68	4054M	68	4204	70
3901	20	4002M	68	4056	68	4204-DM	73
3902	66	4003	68	4056D	68	4204M	70
3902M	66	4004	68	4056M	68	4301	22
3903	66	4004-DM	72	4057	68	4302	70
3905	20	4004M	68	4059	125	4302M	70
3906	66	4005	21	4059A	125	4303	70
3906M	66	4006	68	4060	125	4304	70
3907	66	4006D	68	4072	68	4304-DM	73
3909	124	4006M	68	4072D	68	4304M	70
3910	124	4007	68	4072M	68	4410	26



Model Number	Page	Model Number	Page	Model Number	Page	Model Number	Page
4410-DM	82	4438-L	80	4476-L	80	4546	74
4410-DM-L	82	4439	80	4477	80	4546D	74
4411	80	4439-L	80	4477-L	80	4546M	74
4411-L	80	4450	26	4478	80	4547	74
4412	80	4450-DM	82	4478-L	80	4552	74
4412-DM	82	4450-DM-L	82	4479	80	4552D	74
4412-DM-L	82	4451	80	4479-L	80	4552M	74
4412-L	80	4451-L	80	4499	126	4553	74
4413	80	4452	80	4501	23	4554	74
4413-L	80	4452-DM	82	4502	74	4554M	74
4414	80	4452-DM-L	82	4502D	74	4556	74
4414-L	80	4452-L	80	4502M	74	4556D	74
4416	80	4453	80	4504-DM	78	4556M	74
4416-L	80	4453-L	80	4503	74	4557	74
4417	80	4454	80	4504	74	4559	126
4417-L	80	4454-L	80	4504M	74	4560	126
4418	80	4456	80	4506	74	4572	74
4418-L	80	4456-L	80	4506D	74	4572D	74
4419	80	4457	80	4507	74	4572M	74
4419-L	80	4457-L	80	4506M	74	4573	74
4421	80	4458	80	4508-DM	78	4574	74
4421-L	80	4458-L	80	4509	124	4574M	74
4422	80	4459	80	4510	125	4575	118
4422-L	80	4459-L	80	4522	74	4576	74
4423	80	4461	80	4522D	74	4576D	74
4423-L	80	4461-L	80	4522M	74	4576M	74
4424	80	4462	80	4523	74	4577	74
4424-L	80	4462-L	80	4524	74	4582	74
4426	80	4463	80	4524M	74	4582D	74
4426-L	80	4463-L	80	4526	74	4582M	74
4427	80	4464	80	4526D	74	4583	74
4427-L	80	4464-L	80	4526M	74	4584	74
4428	80	4466	80	4527	74	4584M	74
4428-L	80	4466-L	80	4532	74	4586	74
4429	80	4467	80	4532D	74	4586D	74
4429-L	80	4467-L	80	4532M	74	4586M	74
4431	80	4468	80	4533	74	4587	74
4431-L	80	4468-L	80	4534	74	4592	74
4432	80	4469	80	4534M	74	4592D	74
4432-L	80	4469-L	80	4536	74	4592M	74
4433	80	4471	80	4536D	74	4593	74
4433-L	80	4471-L	80	4536M	74	4594	74
4434	80	4472	80	4537	74	4594M	74
4434-L	80	4472-L	80	4542	74	4596	74
4436	80	4473	80	4542D	74	4596D	74
4436-L	80	4473-L	80	4542M	74	4596M	74
4437	80	4474	80	4543	74	4597	74
4437-L	80	4474-L	80	4544	74	4601	24
4438	80	4476	80	4544M	74	4602	77

Model Number Index

Model Number	Page	Model Number	Page	Model Number	Page	Model Number	Page
4602M	77	4945-06	86	9511E	128	CR4072D	92
4603	77	4945-06-L	86	9511M	128	CR4072M	92
4604	77	4945-08	86	9512E	128	CR4082	92
4604-DM	79	4945-08-L	86	9512M	128	CR4082D	92
4604M	77	4945-10	86	9524E	128	CR4082M	92
4606	25	4945-10-L	86	9524M	128	CR4092	92
4609	25	4945-12	86	9526E	128	CR4092D	92
4612	25	4945-12-L	86	9526M	128	CR4092M	92
4615	25	4955-04	86	9531E	128	CR4101	41
4701	24	4955-04-L	86	9531M	128	CR4102	95
4702	77	4955-06	86	9532E	128	CR4102M	95
4702M	77	4955-06-L	86	9532M	128	CR4103	95
4703	77	4955-08	86	9551	129	CR4104	95
4704	77	4955-08-L	86	9552	129	CR4104-DM	96
4704-DM	79	4955-10	86	9560	129	CR4104M	95
4704M	77	4955-10-L	86	9570	129	CR4201	41
4801	24	4955-12	86	9575	129	CR4202	95
4802	77	4955-12-L	86	10000	119	CR4202M	95
4802M	77	4965-04	86	10001	119	CR4203	95
4803	77	4965-04-L	86	20000	119	CR4204	95
4804	77	4965-06	86	20001	119	CR4204-DM	96
4804-DM	79	4965-06-L	86	30005-P	120	CR4204M	95
4804M	77	4965-08	86	30005-S	120	CR4301	41
4900-02	27	4965-08-L	86	30006-P	120	CR4302	95
4900-04	28	4965-10	86	30006-S	120	CR4302M	95
4900-06	28	4965-10-L	86	30008-P	120	CR4303	95
4900-08	28	4965-12	86	30008-S	120	CR4304	95
4900-10	28	4965-12-L	86	30010-P	120	CR4304-DM	96
4900-12	28	4990-02	127	30010-S	120	CR4304M	95
4910	84	4990-04	127	30012-P	120	CR4410	50
4910-L	84	4990-06	127	30012-S	120	CR4411	104
4911	84	4990-08	127	CR4001	40	CR4411-DM	106
4911-DM	85	4990-10	127	CR4002	92	CR4411-DM-L	106
4911-DM-L	85	4990-12	127	CR4002D	92	CR4411-L	104
4911-L	84	5000	132	CR4002M	92	CR4412	104
4912	84	5100	132	CR4002-DM	94	CR4412-DM	106
4912-L	84	5300	132	CR4022	92	CR4412-DM-L	106
4913	84	5500		CR4022D	92	CR4412-L	104
4913-L	84	5505		CR4022M	92	CR4413	104
4914	84	5510	Contact Factory	CR4032	92	CR4413-L	104
4914-L	84	5550		CR4032D	92	CR4414	104
4915	84	5650		CR4032M	92	CR4414-L	104
4915-L	84	5700	132	CR4042	92	CR4416	104
4916	84	5800	132	CR4042D	92	CR4416-L	104
4916-L	84	5900	132	CR4042M	92	CR4417	104
4917	84	5950		CR4052	92	CR4417-L	104
4917-L	84	9002	Contact Factory	CR4052D	92	CR4418	104
4945-04	86	9006		CR4052M	92	CR4418-L	104
4945-04-L	86	9007		CR4072	92	CR4419	104



Model Number	Page	Model Number	Page	Model Number	Page	Model Number	Page
CR4419-L	104	CR4457-L	104	CR4507	98	CR4576M	98
CR4421	104	CR4458	104	CR4522	98	CR4577	98
CR4421-L	104	CR4458-L	104	CR4522D	98	CR4582	98
CR4422	104	CR4459	104	CR4522M	98	CR4582D	98
CR4422-L	104	CR4459-L	104	CR4523	98	CR4582M	98
CR4423	104	CR4461	104	CR4524	98	CR4583	98
CR4423-L	104	CR4461-L	104	CR4524M	98	CR4584	98
CR4424	104	CR4462	104	CR4526	98	CR4584M	98
CR4424-L	104	CR4462-L	104	CR4526D	98	CR4586	98
CR4426	104	CR4463	104	CR4526M	98	CR4586D	98
CR4426-L	104	CR4463-L	104	CR4527	98	CR4586M	98
CR4427	104	CR4464	104	CR4532	98	CR4587	98
CR4427-L	104	CR4464-L	104	CR4532D	98	CR4592	98
CR4428	104	CR4466	104	CR4532M	98	CR4592D	98
CR4428-L	104	CR4466-L	104	CR4533	98	CR4592M	98
CR4429	104	CR4467	104	CR4534	98	CR4593	98
CR4429-L	104	CR4467-L	104	CR4534M	98	CR4594	98
CR4431	104	CR4468	104	CR4536	98	CR4594M	98
CR4431-L	104	CR4468-L	104	CR4536D	98	CR4596	98
CR4432	104	CR4469	104	CR4536M	98	CR4596D	98
CR4432-L	104	CR4469-L	104	CR4537	98	CR4596M	98
CR4433	104	CR4471	104	CR4542	98	CR4597	98
CR4433-L	104	CR4471-L	104	CR4542D	98	CR4601	45
CR4434	104	CR4472	104	CR4542M	98	CR4602	100
CR4434-L	104	CR4472-L	104	CR4543	98	CR4602M	100
CR4436	104	CR4473	104	CR4544	98	CR4603	100
CR4436-L	104	CR4473-L	104	CR4544M	98	CR4604	100
CR4437	104	CR4474	104	CR4546	98	CR4604-DM	101
CR4437-L	104	CR4474-L	104	CR4546D	98	CR4604M	100
CR4438	104	CR4476	104	CR4546M	98	CR4701	45
CR4438-L	104	CR4476-L	104	CR4547	98	CR4702	100
CR4439	104	CR4477	104	CR4552	98	CR4702M	100
CR4439-L	104	CR4477-L	104	CR4552D	98	CR4703	100
CR4450	50	CR4478	104	CR4552M	98	CR4704	100
CR4451	104	CR4478-L	104	CR4553	98	CR4704-DM	101
CR4451-DM	106	CR4479	104	CR4554	98	CR4704M	100
CR4451-DM-L	106	CR4479-L	104	CR4554M	98	CR4801	45
CR4451-L	104	CR4501	44	CR4556	98	CR4802	100
CR4452	104	CR4502	98	CR4556D	98	CR4802M	100
CR4452-DM	106	CR4502D	98	CR4556M	98	CR4803	100
CR4452-DM-L	106	CR4502M	98	CR4557	98	CR4804	100
CR4452-L	104	CR4503	98	CR4572	98	CR4804-DM	101
CR4453	104	CR4504	98	CR4572D	98	CR4804M	100
CR4453-L	104	CR4504-DM	101	CR4572M	98	CR4900-04	51
CR4454	104	CR4504M	98	CR4573	98	CR4900-06	51
CR4454-L	104	CR4505	44	CR4574	98	CR4900-08	51
CR4456	104	CR4506	98	CR4574M	98	CR4900-10	51
CR4456-L	104	CR4506D	98	CR4576	98	CR4900-12	51
CR4457	104	CR4506M	98	CR4576D	98	CR4910	108

Model Number Index

Model Number	Page	Model Number	Page	Model Number	Page	Model Number	Page
CR4910-L	108	M2530	117	M4002	68	M4054	68
CR4911	108	M2535	117	M4002D	68	M4054M	68
CR4911-DM	109	M3901	20	M4002M	68	M4056	68
CR4911-DM-L	109	M3902	66	M4003	68	M4056D	68
CR4911-L	108	M3902M	66	M4004	68	M4056M	68
CR4912	108	M3903	66	M4004-DM	72	M4057	68
CR4912-L	108	M3905	20	M4004M	68	M4059	125
CR4913	108	M3906	66	M4005	21	M4059A	125
CR4913-L	108	M3906M	66	M4006	68	M4060	125
CR4914	108	M3907	66	M4006D	68	M4072	68
CR4914-L	108	M3909	124	M4006M	68	M4072D	68
CR4915	108	M3910	124	M4007	68	M4072M	68
CR4915-L	108	M3922	66	M4008-DM	72	M4073	68
CR4916	108	M3922M	66	M4009	124	M4074	68
CR4916-L	108	M3923	66	M4010	124	M4074M	68
CR4917	108	M3926	66	M4022	68	M4076	68
CR4917-L	108	M3926M	66	M4022D	68	M4076D	68
CR4945-04	110	M3927	66	M4022M	68	M4076M	68
CR4945-04-L	110	M3932	66	M4023	68	M4077	68
CR4945-06	110	M3932M	66	M4024	68	M4082	68
CR4945-06-L	110	M3933	66	M4024M	68	M4082D	68
CR4945-08	110	M3936	66	M4026	68	M4082M	68
CR4945-08-L	110	M3936M	66	M4026D	68	M4083	68
CR4945-10	110	M3937	66	M4026M	68	M4084	68
CR4945-10-L	110	M3942	66	M4027	68	M4084M	68
CR4945-12	110	M3942M	66	M4032	68	M4086	68
CR4945-12-L	110	M3943	66	M4032D	68	M4086D	68
CR4955-04	110	M3946	66	M4032M	68	M4086M	68
CR4955-04-L	110	M3946M	66	M4033	68	M4087	68
CR4955-06	110	M3947	66	M4034	68	M4092	68
CR4955-06-L	110	M3952	66	M4034M	68	M4092D	68
CR4955-08	110	M3952M	66	M4036	68	M4092M	68
CR4955-08-L	110	M3956	66	M4036D	68	M4093	68
CR4955-10	110	M3956M	66	M4036M	68	M4094	68
CR4955-10-L	110	M3959	124	M4037	68	M4094M	68
CR4955-12	110	M3960	124	M4042	68	M4096	68
CR4955-12-L	110	M3972	66	M4042D	68	M4096D	68
CR4965-04	110	M3972M	66	M4042M	68	M4096M	68
CR4965-04-L	110	M3976	66	M4043	68	M4097	68
CR4965-06	110	M3976M	66	M4044	68	M4101	22
CR4965-06-L	110	M3982	66	M4044M	68	M4102	70
CR4965-08	110	M3982M	66	M4046	68	M4102M	70
CR4965-08-L	110	M3986	66	M4046D	68	M4103	70
CR4965-10	110	M3986M	66	M4046M	68	M4104	70
CR4965-10-L	110	M3992	66	M4047	68	M4104-DM	73
CR4965-12	110	M3992M	66	M4052	68	M4104M	70
CR4965-12-L	110	M3996	66	M4052D	68	M4201	22
M2520	117	M3996M	66	M4052M	68	M4202	70
M2525	117	M4001	21	M4053	68	M4202M	70

Model Number	Page	Model Number	Page	Model Number	Page	Model Number	Page
M4203	70	M4431-L	80	M4468-L	80	M4533	74
M4204	70	M4432	80	M4469	80	M4534	74
M4204-DM	73	M4432-L	80	M4469-L	80	M4534M	74
M4204M	70	M4433	80	M4471	80	M4536	74
M4301	22	M4433-L	80	M4471-L	80	M4536D	74
M4302	70	M4434	80	M4472	80	M4536M	74
M4302M	70	M4434-L	80	M4472-L	80	M4537	74
M4303	70	M4436	80	M4473	80	M4542	74
M4304	70	M4436-L	80	M4473-L	80	M4542D	74
M4304-DM	73	M4437	80	M4474	80	M4542M	74
M4304M	70	M4437-L	80	M4474-L	80	M4543	74
M4410	26	M4438	80	M4476	80	M4544	74
M4410-DM	82	M4438-L	80	M4476-L	80	M4544M	74
M4410-DM-L	82	M4439	80	M4477	80	M4546	74
M4411	80	M4439-L	80	M4477-L	80	M4546D	74
M4411-L	80	M4450	26	M4478	80	M4546M	74
M4412	80	M4450-DM	82	M4478-L	80	M4547	74
M4412-DM	82	M4450-DM-L	82	M4479	80	M4552	74
M4412-DM-L	82	M4451	80	M4479-L	80	M4552D	74
M4412-L	80	M4451-L	80	M4499	126	M4552M	74
M4413	80	M4452	80	M4501	23	M4553	74
M4413-L	80	M4452-DM	82	M4502	74	M4554	74
M4414	80	M4452-DM-L	82	M4502D	74	M4554M	74
M4414-L	80	M4452-L	80	M4502M	74	M4556	74
M4416	80	M4453	80	M4503	74	M4556D	74
M4416-L	80	M4453-L	80	M4504	74	M4556M	74
M4417	80	M4454	80	M4504-DM	78	M4557	74
M4417-L	80	M4454-L	80	M4504M	74	M4559	126
M4418	80	M4456	80	M4505	23	M4560	126
M4418-L	80	M4456-L	80	M4506	74	M4572	74
M4419	80	M4457	80	M4506D	74	M4572D	74
M4419-L	80	M4457-L	80	M4506M	74	M4572M	74
M4421	80	M4458	80	M4507	74	M4573	74
M4421-L	80	M4458-L	80	M4508-DM	78	M4574	74
M4422	80	M4459	80	M4509	124	M4574M	74
M4422-L	80	M4459-L	80	M4510	125	M4575	118
M4423	80	M4461	80	M4522	74	M4576	74
M4423-L	80	M4461-L	80	M4522D	74	M4576D	74
M4424	80	M4462	80	M4522M	74	M4576M	74
M4424-L	80	M4462-L	80	M4523	74	M4577	74
M4426	80	M4463	80	M4524	74	M4582	74
M4426-L	80	M4463-L	80	M4524M	74	M4582D	74
M4427	80	M4464	80	M4526	74	M4582M	74
M4427-L	80	M4464-L	80	M4526D	74	M4583	74
M4428	80	M4466	80	M4526M	74	M4584	74
M4428-L	80	M4466-L	80	M4527	74	M4584M	74
M4429	80	M4467	80	M4532	74	M4586	74
M4429-L	80	M4467-L	80	M4532D	74	M4586D	74
M4431	80	M4468	80	M4532M	74	M4586M	74

Model Number Index

Model Number	Page	Model Number	Page	Model Number	Page	Model Number	Page
M4587	74	M4914-L	84	M30006-P	120	SK075A-200	102
M4592	74	M4915	84	M30006-S	120	SK100A-150	103
M4592D	74	M4915-L	84	M30008-P	120	SK100A-200	103
M4592M	74	M4916	84	M30008-S	120	SK100A-250	103
M4593	74	M4916-L	84	M30010-P	120	SK100A-300	103
M4594	74	M4917	84	M30010-S	120	SP050A-075	43
M4594M	74	M4917-L	84	M30012-P	120	SP050A-125	43
M4596	74	M4945-04	86	M30012-S	120	SP050A-175	43
M4596D	74	M4945-04-L	86	MM-1 X	64	SP075A-150	47
M4596M	74	M4945-06	86	MM-1 X-Y	64	SP075A-200	47
M4597	74	M4945-06-L	86	MM-1 X-Y-Z	64	SP100A-150	49
M4601	24	M4945-08	86	MM-3 X	64	SP100A-200	49
M4602	77	M4945-08-L	86	MM-3 X-Y	64	SP100A-250	49
M4602M	77	M4945-10	86	MM-3 X-Y-Z	64	SP100A-300	49
M4603	77	M4945-10-L	86	SC050A-075	97	SW038A-050	39
M4604	77	M4945-12	86	SC050A-125	97	SW038A-075	39
M4604-DM	79	M4945-12-L	86	SC050A-175	97	SW038A-100	39
M4604M	77	M4955-04	86	SC075A-100	102	SW038A-125	39
M4701	24	M4955-04-L	86	SC075A-150	102	SW038A-150	39
M4702	77	M4955-06	86	SC075A-200	102	SW038A-175	39
M4702M	77	M4955-06-L	86	SC100A-150	103	SW038A-225	39
M4703	77	M4955-08	86	SC100A-200	103		
M4704	77	M4955-08-L	86	SC100A-250	103		
M4704-DM	79	M4955-10	86	SC100A-300	103		
M4704M	77	M4955-10-L	86	SE050A-050	42		
M4801	24	M4955-12	86	SE050A-075	42		
M4802	77	M4955-12-L	86	SE050A-100	42		
M4802M	77	M4965-04	86	SE050A-125	42		
M4803	77	M4965-04-L	86	SE050A-150	42		
M4804	77	M4965-06	86	SE050A-175	42		
M4804-DM	79	M4965-06-L	86	SE050A-225	42		
M4804M	77	M4965-08	86	SE075A-075	46		
M4900-02	27	M4965-08-L	86	SE075A-100	46		
M4900-04	28	M4965-10	86	SE075A-125	46		
M4900-06	28	M4965-10-L	86	SE075A-150	46		
M4900-08	28	M4965-12	86	SE075A-175	46		
M4900-10	28	M4965-12-L	86	SE075A-225	46		
M4900-12	28	M4990-02	127	SE100A-100	48		
M4910	84	M4990-04	127	SE100A-150	48		
M4910-L	84	M4990-06	127	SE100A-250	48		
M4911	84	M4990-08	127	SE100A-350	48		
M4911-DM	85	M4990-10	127	SK050A-075	97		
M4911-DM-L	85	M4990-12	127	SK050A-125	97		
M4911-L	84	M10000	119	SK050A-175	97		
M4912	84	M10001	119	SK075A-100	102		
M4912-L	84	M20000	119	SK075A-150	102		
M4913	84	M20001	119				
M4913-L	84	M30005-P	120				
M4914	84	M30005-S	120				



The items described in this document and other documents or descriptions provided by Parker Daedal, its subsidiaries and its authorized distributors are hereby offered for sale at prices to be established by Parker Daedal, its subsidiaries and its authorized distributors. This offer and its acceptance by any customer ("Buyer") shall be governed by all of the following Terms and Conditions. Buyer's order for any such item, when communicated to Parker Daedal, its subsidiary or an authorized distributor ("Seller") verbally or in writing, shall constitute acceptance of this offer.

1. **Terms and Conditions of Sale:** All descriptions, quotations, proposals, offers, acknowledgments, acceptances and sales of Seller's products are subject to and shall be governed exclusively by the terms and conditions stated herein. Buyer's acceptance of any offer to sell is limited to these terms and conditions. Any terms or conditions in addition to, or inconsistent with those stated herein, proposed by Buyer in any acceptance of an offer by Seller, are hereby objected to. No such additional, different or inconsistent terms and conditions shall become part of the contract between, Buyer and Seller unless expressly accepted in writing by Seller. Seller's acceptance of any offer to purchase by Buyer is expressly conditional upon Buyer's assent to all the terms and conditions stated herein, including any terms in addition to, or inconsistent with those contained in Buyer's offer. Acceptance of Seller's products shall in all events constitute such assent.

2. **Payment:** Payment shall be made by Buyer net 30 days from the date of delivery of the items purchased hereunder. Amounts not timely paid shall bear interest at the maximum rate permitted by law for each month or portion thereof that the Buyer is late in making payment. Any claims by Buyer for omissions or shortages in a shipment shall be waived unless Seller receives notice thereof within 30 days after Buyer's receipt of the shipment.

3. **Delivery:** Unless otherwise provided on the face hereof, delivery shall be made F.O.B. Seller's plant. Regardless of the method of delivery, however, risk of loss shall pass to Buyer upon Seller's delivery to a carrier. Any delivery dates shown are approximate only and Seller shall have no liability for any delays in delivery.

4. **Warranty:** Seller warrants that the items sold hereunder shall be free from defects in material or workmanship for a period of 12 months from date of shipment from Parker Daedal. THIS WARRANTY COMPRISES THE SOLE AND ENTIRE WARRANTY PERTAINING TO ITEMS PROVIDED HEREUNDER. SELLER MAKES NO OTHER WARRANTY, GUARANTEE, OR REPRESENTATION OF ANY KIND WHATSOEVER. ALL OTHER WARRANTIES, INCLUDING BUT NOT LIMITED TO, MERCHANTABILITY AND FITNESS FOR PURPOSE, WHETHER EXPRESS, IMPLIED, OR ARISING BY OPERATION OF LAW, TRADE USAGE, OR COURSE OF DEALING ARE HEREBY DISCLAIMED. NOTWITHSTANDING THE FOREGOING, THERE ARE NO WARRANTIES WHATSOEVER ON ITEMS BUILT OR ACQUIRED WHOLLY OR PARTIALLY, TO BUYER'S DESIGNS OR SPECIFICATIONS.

5. **Limitation of Remedy:** SELLER'S LIABILITY ARISING FROM OR IN ANY WAY CONNECTED WITH THE ITEMS SOLD OR THIS CONTRACT SHALL BE LIMITED EXCLUSIVELY TO REPAIR OR REPLACEMENT OF THE ITEMS SOLD OR REFUND OF THE PURCHASE PRICE PAID BY BUYER, AT SELLER'S SOLE OPTION. IN NO EVENT SHALL SELLER BE LIABLE FOR ANY INCIDENTAL, CONSEQUENTIAL OR SPECIAL DAMAGES OF ANY KIND OR NATURE WHATSOEVER, INCLUDING BUT NOT LIMITED TO LOST PROFITS ARISING FROM OR IN ANY WAY CONNECTED WITH THIS AGREEMENT OR ITEMS SOLD HEREUNDER, WHETHER ALLEGED TO ARISE FROM BREACH OF CONTRACT, EXPRESS OR IMPLIED WARRANTY, OR IN TORT, INCLUDING WITHOUT LIMITATION, NEGLIGENCE, FAILURE TO WARN OR STRICT LIABILITY.

6. **Changes, Reschedules and Cancellations:** Buyers may request to modify the designs or specifications for the items sold hereunder as well as the quantities and delivery dates thereof, or may request to cancel all or part of this order, however, no such requested modification or cancellation shall become part of the contract between Buyer and Seller unless accepted by Seller in a written amendment to this Agreement. Acceptance of any such requested modification of cancellation shall be at Seller's discretion, and shall be upon such terms and conditions as Seller may require.

7. **Special Tooling:** A tooling charge may be imposed for any special tooling, including without limitation, dies, fixtures, molds and patterns, acquired to manufacture items sold pursuant to this contract. Such special tooling shall be and remain Seller's property notwithstanding payment of any charges by Buyer. In no event will Buyer acquire any interest in apparatus belonging to Seller which is utilized in the manufacture of the items sold hereunder, even if such apparatus has been specially converted or adapted for such manufacture and not withstanding any charges paid by Buyer. Unless otherwise agreed, Seller shall have the right to alter, discard or otherwise dispose of any special tooling or other property in its sole discretion at any time.

8. **Buyer's Property:** Any designs, tools, patterns, materials, drawings confidential information or equipment furnished by Buyer, or any other items which become Buyer's property, may be considered obsolete and may be destroyed by Seller after two (2) consecutive years have elapsed without Buyer placing an order for the items which are manufactured using such property. Seller shall not be responsible for any loss or damage to such property while it is in Seller's possession or control.

9. **Taxes:** Unless otherwise indicated on the face hereof, all prices and charges are exclusive of excise, sales, use, property, occupational or like taxes which may be imposed by any taxing authority upon the manufacture, sale or delivery of the items sold hereunder. If any such taxes must be paid by Seller or if Seller is liable for the collection of such tax, the amount thereof shall be in addition to the amounts for the items sold. Buyer agrees to pay all such taxes or to reimburse Seller therefore upon receipt of its invoice. If Buyer claims exemption from any sales, use or other tax imposed by any taxing authority, Buyer shall save Seller harmless from and against any such tax, together with any interest or penalties thereon which may be assessed if the items are held to be taxable.

10. **Indemnity For Infringement of Intellectual Property Rights:** Seller shall have no liability for infringement of any patents, trademarks, copyrights, trade dress, trade secrets or similar rights except as provided in this Part 10. Seller will defend and indemnify Buyer against allegations of infringement of U.S. patents, U.S. trademarks, copyrights, trade dress and trade secrets (hereinafter 'Intellectual Property Rights'). Seller will defend at its expense and will pay the cost of any settlement or damages awarded in an action brought against Buyer based on an allegation that an item sold pursuant to this contract infringes the Intellectual Property Rights of a third party. Seller's obligation to defend and indemnify Buyer is contingent on Buyer notifying Seller within ten (10) days after Buyer becomes aware of such allegations of infringement, and Seller having sole control over the defense of any allegations or actions including all negotiations for settlement or compromise. If an item sold hereunder is subject to a claim that it infringes the Intellectual Property Rights of a third party, Seller may, at its sole expense and option, procure for Buyer the right to continue using said item, replace or modify said item so as to make it non infringing, or offer to accept return of said item and return the purchase price less a reasonable allowance for depreciation. Notwithstanding the foregoing, Seller shall have no liability for claims of infringement based on information provided by Buyer, or directed to items delivered hereunder for which the designs are specified in whole or part by Buyer, or infringements resulting from the modification, combination or use in a system of any item sold hereunder. The foregoing provisions of this Part 10 shall constitute Seller's sole and exclusive liability and Buyer's sole and exclusive remedy for infringement of Intellectual Property Right. If a claim is based on information provided by Buyer or if the design for an item delivered hereunder is specified in whole or in part by Buyer, Buyer shall defend and indemnify Seller for all costs, expenses or judgments resulting from any claim that such item infringes any patent, trademark, copyright, trade dress, trade secret or any similar right.

11. **Force Majeure:** Seller does not assume the risk of and shall not be liable for delay or failure to perform any of Seller's obligations by reason of circumstances beyond the reasonable control of Seller (hereinafter 'Events of Force Majeure'). Events of Force Majeure shall include without limitation, accidents, acts of God, strikes or labor disputes, acts, laws, rules or regulations of any government or government agency, fires, floods, delays or failures in delivery of carriers or suppliers, shortages of materials and any other cause beyond Seller's control.

12. **Entire Agreement/Governing Law:** The terms and conditions set forth herein, together with any amendments, modifications and any different terms or conditions expressly accepted by Seller in writing, shall constitute the entire Agreement concerning the items sold, and there are no oral or other representations or agreements which pertain thereto. This Agreement shall be governed in all respects by the law of the State of Ohio. No actions arising out of the sale of the items sold hereunder of this Agreement may be brought by either party more than two (2) years after the cause of action accrues.

 **WARNING**

FAILURE OR IMPROPER SELECTION OR IMPROPER USE OF THE PRODUCTS AND/OR SYSTEMS DESCRIBED HEREIN OR RELATED ITEMS CAN CAUSE DEATH, PERSONAL INJURY AND PROPERTY DAMAGE.

This document and other information from Parker Hannifin Corporation, its subsidiaries and authorized distributors provide product and/or system options for further investigation by users having technical expertise. It is important that you analyze all aspects of your application and review the information concerning the product or system in the current product catalog. Due to the variety of operating conditions and applications for these products or systems, the user, through its own analysis and testing, is solely responsible for making the final selection of the products and systems and assuring that all performance, safety and warning requirements of the application are met.

The products described herein, including without limitation, product features, specifications, designs, availability and pricing, are subject to change by Parker Hannifin Corporation and its subsidiaries at any time without notice.

Offer of Sale

The items described in this document are hereby offered for sale by Parker Hannifin Corporation, its subsidiaries or its authorized distributors. This offer and its acceptance are governed by the provisions stated in the "Offer of Sale" found on www.parker.com/emn.

©2020 Parker Hannifin Corporation, All Rights Reserved

EM&D Sales Offices

Australia

Parker Hannifin (Australia) Pty Ltd.
9 Carrington Road
Castle Hill NSW 2154
Australia
Tel: +61 (0) 2 9634-7777
Fax: +61 (0) 2 9634 3749

Brazil

Parker Hannifin Ind. Com Ltda.
Av. Lucas Nogueira Garcez 2181
Esperança
12325-900 Jacareí, SP
Tel: 12 3954 5100
Fax: 12 3954 5262
Email: automation.brazil@parker.com

Canada

Parker Hannifin (Canada) Inc.
160 Chisholm Dr
Milton, Ontario L9T 3G9
Tel: 905-693-3000
Fax: 905-876-1958
Email: miltoncustservice@parker.com

China

Parker Hannifin Motion & Control
(Shanghai) Co., Ltd
280 Yunqiao Rd. Jin Qiao Export
Processing Zone
Shanghai 201206, China
Tel: (86-21) 50312525
Fax: (86-21) 64459717

France

Parker Hannifin Manufacturing
France SAS
4 Boulevard Eiffel
CS 40090
21604 Longvic
France
Tel +33 (0) 3 80 42 41 40
Fax +33 (0) 3 80 42 41 30

Germany

Electromechanical Europe
Parker Hannifin GmbH & Co KG
Robert-Bosch-Strasse 22
D-77656 Offenburg
Germany
Tel: +49 (0) 781 509 0
Fax: +49 (0) 781 509 98176
Email: em-motion@parker.com

India

Parker Hannifin India Pvt. Ltd
Automation Group
133 & 151 Developed Plots Estate
Perungudi, Chennai 600 096
Tel: 044-4391-0799
Fax: 044-4391-0700

Italy

Parker Hannifin SpA
Via Gounod 1
20092 Cinsello Balsamo
Milano, Italy
Tel: +39 02 361081
Fax: +39 02 36108400
Email: em-motion@parker.com

Korea

Parker Hannifin Korea
9th Floor KAMCO Yangjae Tower
949-3 Dogok 1-dong Gangnam-gu
Seoul 135-860, Korea
Tel: 82-2-559-0454
Fax: 82-2-556-8187

Mexico

Parker Hannifin de Mexico
Eje uno Norte No.100
Parque Industrial Toluca 2000
Toluca, CP 50100 México
Tel: 52-722-275-4200
Fax: 52-722-279-0316

Singapore

Parker Hannifin Singapore Pte Ltd
11, Fourth Chin Bee Road
Singapore 619702
Tel: (65) 6887 6300
Fax: (65) 6265 5125/6261 4929

Taiwan

Parker Hannifin Taiwan Co., Ltd
No. 40, Wuchuan 3rd Road
Wuku Industrial Park
Taipei County, Taiwan 248
ROC
Tel: 886 2 2298 8987
Fax: 886 2 2298 8982

Thailand

Parker Hannifin (Thailand) Co., Ltd.
1265 Rama 9 Road
Suanluang, Bangkok 10250
Thailand
Tel: (66) 2 186 7000
Fax: (66) 2 374 1645

UK

Parker Hannifin Ltd.
Tachbrook Park Drive
Tachbrook Park
Warwick CV34 6TU
Tel: +44 (0) 1926 317970
Fax: +44 (0) 1926 317980

USA

Parker Hannifin Electromechanical
& Drives Division (Intelligent Motion
Business)
1140 Sandy Hill Road
Irwin, PA 15642 USA
Tel: (724) 861-8200
800-245-6903
Fax: (724) 861-3330
Email: emn_support@parker.com

Parker Hannifin Electromechanical
& Drives Division (Gearhead & Motor
Business)
2101 North Broadway
New Ulm, Minnesota 56073 USA
Tel: (507) 354-1616
800-358-9070
Fax: (507) 233-2390
Email: emn_support@parker.com

Parker Hannifin Electromechanical
& Drives Division (Intelligent Motion
Business)
5500 Business Park Drive
Rohnert Park, CA 94928 USA
Tel: (707) 584-7558
800-358-9070
Fax: (707) 584-8015
Email: emn_support@parker.com

Parker Hannifin Electromechanical
& Drives Division (IPS)
135 Quadral Drive
Wadsworth, OH 44281 USA
Tel: (330) 334-3335
800-358-9070
Fax: (330) 334-2350
Email: emn_support@parker.com

